

606 Delay F/x Machine

606



User's Guide

Table of Contents

<i>Chapter 1</i>	Introduction	1
<i>Chapter 2</i>	Operator Safety Summary	2
<i>Chapter 3</i>	Fast Setup	3
<i>Chapter 4</i>	Front & Rear Panel Controls	4
<i>Chapter 5</i>	Connections	10
<i>Chapter 6</i>	Levels of Operations	12
<i>Chapter 7</i>	Presets	13
<i>Chapter 8</i>	Modifying Factory Presets & Creating Presets	17
<i>Chapter 9</i>	Program Modules	20
<i>Chapter 10</i>	Parameters	26
<i>Chapter 11</i>	Specifications	44
<i>Chapter 12</i>	Troubleshooting	45
<i>Chapter 13</i>	Warranty and Service	46
<i>Appendix A</i>	MIDI Implementation	48
<i>Appendix B</i>	Flow Diagram	54
<i>Appendix C</i>	Parameter Chart	56
<i>Appendix D</i>	Factory Presets	58
<i>Appendix E</i>	Declaration of Conformity	61

Rev A.02, Sept. 1, 1997

Symetrix part number 53606-0A02

Subject to change at our whim and fancy without notice.

©1997, Symetrix, Inc. All right reserved.

Symetrix is a registered trademark of Symetrix, Inc.

Mention of third-party products is for informational purposes only and constitutes neither an endorsement nor a recommendation. Symetrix assumes no responsibility with regard to the performance or use of these products.

Under copyright laws, no part of this manual may be reproduced or transmitted in any form or by any means, electronic or mechanical, including photocopying, scanning, recording or by any information storage and retrieval system, without permission, in writing, from Symetrix, Inc.

 **Symetrix**

14926 35th Ave. West
Lynnwood, WA 98037 USA
Tel (425) 787-3222
Fax (425) 787-3211

Email: symetrix@symetrixaudio.com

6006 Delay F/x Machine

Thank you for your purchase of the 606 Delay F/x Machine. Our inspiration for the 606 came from the classic delays of the seventies. Their broad user controls and easy operation gave musicians and producers a host of signature sounds within quick reach.

With its distinctive tones, superior sound quality and complete creative control, the 606 couples the classics with the cutting edge. It offers all the programming possibilities you could want, and then lets you evolve them live with simple knob adjustments.

In short, the 606 can become much more than a simple delay effect and yet remain very simple to use. Its programming possibilities are extensive, but we've also loaded it with basic presets for use as-is or in some modified form. The Parameter Chart, Preset Chart and Flowchart included with the unit will prove invaluable should you choose to explore the 606's full capabilities.

Of course we recommend that you read this manual cover-to-cover. You'll find the answer to most of your questions inside. However, if you're in a hurry (like most of us), go directly to the Fast Setup section; it will help you get connected and running right away. If you have technical questions beyond the scope of this manual contact our Customer Service Department at:

Phone: (425) 787-3222 (8am - 4:30pm Pacific Time)

Fax: (425) 787-3211

Email: symetrix@symetrixaudio.com

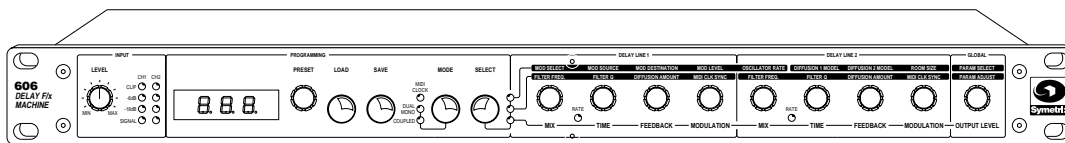

Front panel

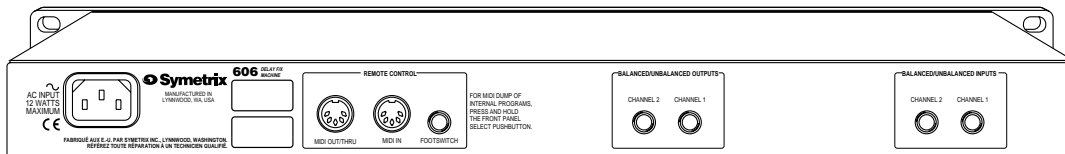

Rear panel

Delay F/x Machine 606

The information in this summary is intended for persons who operate the equipment as well as repair personnel. Specific warnings and cautions are found throughout this manual wherever they may apply; they do not appear in this summary.

The notational conventions used in this manual and on the equipment itself are described in the following paragraphs.

EQUIPMENT MARKINGS

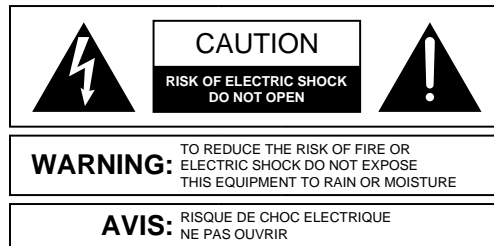

SEE OWNERS MANUAL. VOIR CAHIER D'INSTRUCTIONS.
 No user serviceable parts inside. Refer servicing to qualified service personnel.
 Il ne se trouve a l'interieur aucune piece pouvant entre reparablee l'usager.
 S'adresser a un reparateur competent.

The lightning flash with arrowhead symbol within an equilateral triangle is intended to alert the user of the presence of uninsulated “dangerous voltage” within the product's enclosure that may be of sufficient magnitude to constitute a risk of electric shock to persons.

The exclamation point within an equilateral triangle is intended to alert the user of the presence of important operating and maintenance (servicing) instructions in the literature accompanying the 606 (i.e. this manual).

Caution To prevent electric shock, do not use the polarized plug supplied with the 606 with any extension cord, receptacle, or other outlet unless the blades can be fully inserted.

TERMS

Several notational conventions are used in this manual. Some paragraphs may use **NOTE**, **Caution**, or **Warning** as a heading or certain typefaces and capitalization are used to identify certain words. These are:

NOTE: *Identifies information that needs extra emphasis. A NOTE generally supplies extra information to help you to better use the 606.*

Caution Identifies information that, if not heeded, may cause damage to the 606 or other equipment in your system.

Warning Identifies information that, if ignored, may be hazardous to your health or that of others.

Power source - Electrical power requirements for US and Canadian models are 117 VAC Nominal, 105 to 125 VAC, 60 Hz, 20 Watts maximum. UL and C-UL listing applies only to this rating. This product is intended to operate from a power source that does not apply more than 255Vrms between the power supply conductors or between either power supply conductor and ground. A protective ground connection, by way of the grounding conductor in the power cord, is essential for safe operation.

Danger from loss of ground - If the protective ground connection is lost, all accessible conductive parts, including knobs and controls that may appear to be insulated, can render an electric shock.

Proper power cord - Use only the power cord specified for the product.

Operating location - This product is intended for use in a rack-mounted environment. Do not operate this equipment under any of the following conditions: explosive atmospheres, in wet locations, in inclement weather, improper or unknown AC mains voltage, or if improperly fused.

Stay out of the box - To avoid personal injury or injury to others, do not remove the product covers or panels. Do not operate the product without the covers and panels properly installed.

If you're in a hurry to get the 606 into your sound system and don't have time to thoroughly read this manual, the following steps will probably be enough to get you started:

1. Turn the INPUT LEVEL control completely counterclockwise.
2. Connect the 606 to AC power. If you are using the Tap Tempo footswitch, you need to connect the footswitch before applying AC power, and you should read the rest of this manual, particularly the section about the Tap Tempo Input and the section about Parameter 68.
3. Check to see if the bottom LED of the three LED's to the right of the SELECT button is lit. If one of the other three LED's is lit, press the SELECT button repeatedly until the bottom LED lights. This sets the four DELAY LINE 1 controls and the four DELAY LINE 2 controls to correspond to the parameters that are printed below them (i.e. MIX, TIME, FEEDBACK and MODULATION).
4. Adjust the OUTPUT LEVEL control (on the far right) clockwise until "0.0" appears in the display window.
5. Connect all audio inputs and outputs that you need. Typically, this will entail connecting two cables from your mixing console's auxiliary (or effects) sends to the ¼" CHANNEL 1 and CHANNEL 2 INPUT connectors on the 606. Connect two ¼" cables from the CHANNEL 1 and CHANNEL 2 OUTPUTS of the 606 to either two mono returns on your console, or to a stereo return on your console. These console returns can be auxiliary (or effects) returns, or, if you prefer, you can use line-level channel inputs.
6. Turn the PRESET control until "2CH" appears in the display window of the 606. This preset should be loaded in the #1 preset position (at the beginning of the preset range as you turn the PRESET control counterclockwise) and in the #100 preset position (near the end of the preset range as you turn the PRESET control clockwise). "2CH" should now be flashing in the display window, indicating that it has been selected, but not loaded.
7. Load this preset by pressing the LOAD button, holding the LOAD button in until the display goes blank and then displays "2CH" steadily, without flashing. Now release the LOAD button. You have now set the 606 for independent two-channel operation. This means that the CHANNEL 1 INPUT will feed DELAY LINE 1, which will be routed to the CHANNEL 1 OUTPUT. The CHANNEL 2 INPUT will feed DELAY LINE 2, which will be routed to the CHANNEL 2 OUTPUT.
8. Send audio to the inputs of the 606, and adjust the INPUT CONTROL for a good level (lighting the green SIGNAL and -12dB LED's consistently, and the yellow -6dB LED occasionally). Please note that these LED's are set to measure headroom, so as to prevent clipping the input to the 606's A/D converter. You should not let the input signal reach "0" (clipping) on the INPUT LED's.
9. Adjust the MIX control on each channel for the desired balance of "wet" (delayed) to "dry" (undelayed) signal. If you have the 606 connected to your mixing console's auxiliary or effects sends, then you will probably want to turn this control until "100" appears in the display window, indicating that the audio signal output of the 606 will be "wet" only.
10. Adjust the TIME control on each channel for the desired length of delay.
11. Adjust the FEEDBACK control on each channel for the desired amount of feedback (repeats).
12. Adjust the MODULATION control on each channel until the window display reads "0".
13. Now read the rest of this manual.

Delay F/x
Machine

606

First, some general information about operating the 606's front panel controls.

There are three types of knob controls on the front panel of the 606. The first type of knob control is an attenuator that works in the analog domain. The 606 control of this type is the INPUT LEVEL control. The INPUT LEVEL control is an analog attenuator that allows you to adjust the analog audio signal being fed to the 606 to an optimum level. You want to set this control so that the input level is high enough to give you good resolution in the digital domain, but not so high that you clip the input to the A/D converter. The value set by this knob is indicated by the marks surrounding the knob. This value will not appear in the display window, which only displays the values of digital controls. Please see the following section labeled **Input Level Knob** for further information on setting this control.

The second type of knob control on the front panel of the 606 is a control, operating in the digital domain, that works in conjunction with the LOAD button to select and load presets. The 606 control of this type is the PRESET control. The PRESET control accesses the 109 presets available on the 606. This control operates in the digital domain, so the name of the preset selected by this control will appear in the display window. When you select a preset by turning the PRESET control until the name of the desired preset appears, the preset number will be flashing. This indicates that the preset has been selected, but it has not been loaded. Therefore, the active preset will be the last preset that was loaded.

To load a preset, select the preset by turning the PRESET control until the name of the desired preset appears, then press and hold in the LOAD button. The window display will go blank for about one second, then the preset name will flash once and then come back on steadily. At this point, the preset has been loaded, and you may release the LOAD button. This ability to select a preset without loading it allows you to select the next preset that you want to use, while the preset that you are currently using remains active. If you select your next preset in advance, then when you are ready to switch to the new preset, you simply press and hold in the LOAD button for approximately one second, until the program is loaded.

To turn a knob one increment means to turn either the PRESET knob or one of the parameter knobs in either a clockwise or counterclockwise direction until you feel a “click”. If the name of the currently selected preset is not being shown in the window display, then turning the PRESET knob one increment will cause the window display to show the name of the currently selected preset. Turning the PRESET knob more than one increment will select other presets, until you stop turning the knob, or until you reach the end of the presets. If the name of the currently selected preset was already being shown in the window display, then turning the knob one increment would result in the name of the next preset appearing in the display window. Remember, this new preset would not affect the 606 audio until you load it, by pressing and holding the LOAD button.

The third type of control knob on the 606 front panel is a control, operating in the digital domain, that has multiple functions, which is operated in conjunction with the SELECT button. The 606 controls of this type are the parameter controls, which are the remaining nine front panel knobs that have not been discussed yet. These controls operate in the digital domain, so the values selected by these controls will appear in the display window. Each of the parameter controls has three Command Lines. The LED's in the LED display just to the right of the SELECT button indicate which Command Line has been selected. The Command Line is selected by pressing the SELECT button repeatedly, until the LED that represents the desired Command Line is lit. The bottom Command Line is the row of commands that appears below the parameter controls. These commands are: MIX, TIME, FEEDBACK, MODULATION (the first four apply to Delay Line 1 and are repeated for Delay Line 2), and OUTPUT LEVEL. To select the bottom Command Line, press the SELECT button repeatedly until the bottom LED lights, indicating that the bottom Command Line has been selected. The parameter controls will now correspond to the parameters shown on the bottom Command line.

If the display is not currently showing the parameter value, then turning the parameter knob one increment will cause the window display to show the current value of the parameter assigned to that knob. Turning a parameter knob more than one increment will change the current value of the parameter assigned to that knob, until you reach the end of the values available for that parameter. If the current value of this parameter was already being shown in the window display, turning the knob one increment would result in the parameter value being changed by one increment.

The SAVE button is used to save preset changes, or to save a preset that you have just created to one of the first ninety-nine preset locations (locations 100-109 are read-only). To change a preset, load the preset, then make the desired changes to the parameters. You may notice that when you make parameter changes to a preset, then when you view the preset name, a decimal will appear after the first character. This decimal is to indicate that parameter changes to the preset have occurred, but the changes have not been saved. When you are ready to save your changes, press and hold the SAVE button. The preset name should flash once, then it should come back on steadily, and the decimal will be gone. At this point, you have performed the “save” operation, by overwriting the original preset with your new parameter changes, and you may release the SAVE button.

If, when you press the SAVE button, “Prt” appears in the display window, then the Memory Protect function is engaged, and you will not be allowed to save your parameter changes until you turn off the Memory Protect function. This is accomplished by calling up Parameter 80, which is the Memory Protect parameter. If this parameter is set to “Prt”, then the Memory Protect function is engaged, and you will not be able to save parameter changes. If you set this parameter to OFF, the Memory Protect function will be disabled for the currently loaded preset, and you will be able to save parameter changes to this preset.

To save a preset that you have created to a desired location, set up your new preset parameters and select the preset location where you want to store your new preset. Then, press and hold the SAVE button. The preset name will flash once, then it will come back on steadily, and the decimal will be gone. At this point, you have performed the “save” operation, by overwriting the original preset with your new parameter changes, and you may release the SAVE button. If you wish to assign a three-character name of your choosing to this new preset, Parameters 75, 76 and 77 will allow you to do this.

If, when you press the SAVE button, “Prt” appears in the display window, then the Memory Protect function is engaged, and you will not be allowed to save your new preset until you turn off the Memory Protect function. This is accomplished by calling up Parameter 80, which is the Memory Protect parameter. If this parameter is set to “Prt”, then the Memory Protect function is engaged, and you will not be able to overwrite the currently loaded preset. If you set this parameter to “OFF”, the Memory Protect function will be disabled for the currently loaded preset, and you will be able to save your new preset to the preset location of the currently loaded preset.

Now, we will go through each control, individually.

6006 Delay F/x Machine

FRONT PANEL

Input Level Knob - This allows calibration of the input signal to the 606. The knob controls both Channel 1 and Channel 2 inputs simultaneously. It is used as an overall adjustment to match with the output of other devices such as an audio console's aux sends.

Input level LED's - Clip, -6dB, -18dB, SIGNAL present. These LED's indicate the input level for Channel 1 and Channel 2. The optimum signal level will approach 0 but not exceed it, as exceeding it will clip the analog to digital converter and cause distortion.

Bypass Mode - You're right, there is no bypass switch. BYPASS mode is achieved by pressing the LOAD button twice in quick succession. In BYPASS mode, the window display will flash "out". To leave BYPASS mode, press the LOAD button one more time.

Value window - Displays parameter numbers, parameter values and preset numbers/names. Turning a knob one increment will display the current parameter value without change. A turn to the next increment will increase or decrease the parameter value.

Preset knob - Turn the PRESET knob one increment to display the current preset in the value window. Turning to the next increment will ready the next program for loading. The preset will flash until loaded or changed.

Load button - Press the LOAD button to engage the preset whose number is

displayed in the value window. Pressing the LOAD button twice in quick succession will put the 606 into bypass mode. The value window will read OUT at that point. Press LOAD once again while in bypass mode to return to the preset that was loaded before bypass was engaged.

Save button - Pressing the SAVE button will place the current set of parameters into the preset number selected in the value window. To choose which number you want to save the program to, simply turn the PRESET knob until the desired preset number appears and then press SAVE. If this number is restricted and you cannot save the preset, check Parameter 80 in the GLOBAL control to see if the unit is in Memory Protect mode. If it reads "Prt" you may change the setting to OFF and proceed to SAVE the program.

MIDI Clock Active LED - This indicates that the 606 is receiving MIDI CLOCK signals through the MIDI in plug on the back of the unit.

Mode button - Toggles between DUAL MONO and COUPLED modes. DUAL MONO mode allows the 606 to act as two separate delay lines. COUPLED means that the delay lines' signals are tied together in some way. Pushing the MODE button when a COUPLED program is loaded will force the two delay lines into DUAL MONO mode thus separating whatever signal link they had. Pushing the MODE button again will restore the program to COUPLED mode. If there are no links programmed, the MODE button will not respond when pushed. Once a link has been

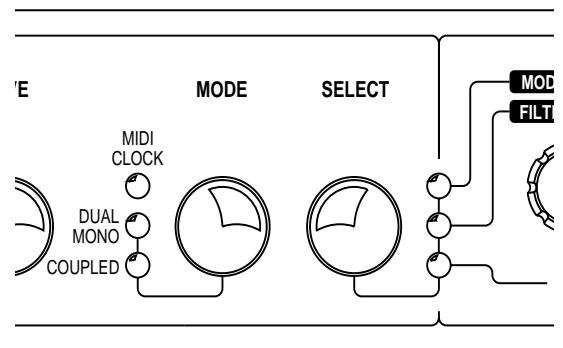
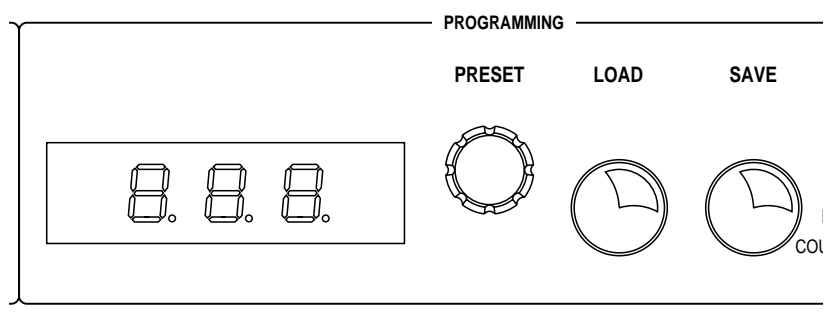
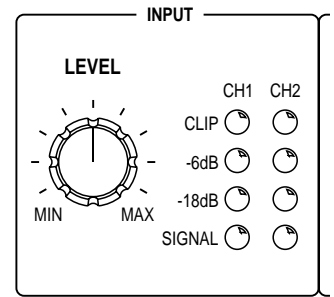

Delay F/x
Machine

606

made in the parameters, the COUPLED LED will light to show the status of the program.

Dual Mono LED - This LED is on when the two delay lines in the 606 are completely separated and can be used as independent effects processors. Single channel programs (in which the output of Delay 1 is run into the input of Delay 2) are still considered DUAL MONO programs because you can access the output of Delay 1 independently of the output of Delay 2.

Coupled LED - When lit this LED indicates that the two delay lines in the 606 are sharing some part of the input signal(s) or feedback between them. There are many ways of routing a signal through the 606 in which Delay 1 and 2 can share parts of the signal.

Select Button and LED's - (command level button) - Pressing the SELECT button will determine which command line the encoder knobs on the 606 will affect. When the lowest LED is lit the knob function corresponds to the labeling on the bottom row. Pressing the button again will move the knobs' designated function to the next level. Pressing a third time will cause the knobs to affect the highest row of listed functions. When working with the Global parameters it is possible to travel back and forth from the top level to the second level without passing through the bottom level. Adjusting the parameter SELECT knob causes the MODE switch to activate the middle level command line instead of the lowest row.

NOTE: On MIDI SysEx dumps - Holding the SELECT button down for an extended time will dump the preset memory via sysex MIDI. If you press and hold the MODE button while pressing the SELECT button, the 606 will off-load only the current preset information loaded in the edit buffer.

Knob 1 - Controls according to command line chosen:

Bottom Row - MIX - Varies the amount of wet/dry signal passing through Delay 1.

Middle Row - FILTER FREQUENCY - Adjusts the center frequency of the filter for Delay 1.

Top Row - MOD SELECT - Selects which modulation module will be edited.

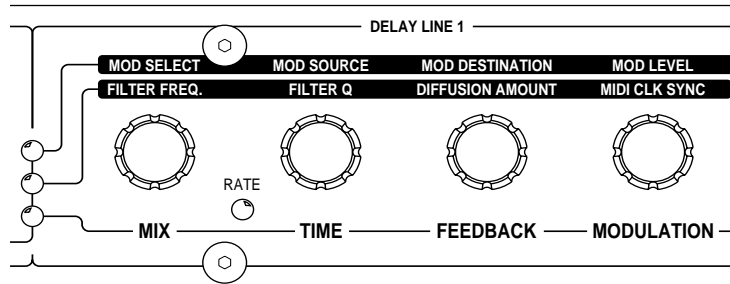

Knob 2 - Controls according to command line chosen:

Bottom Row - DELAY TIME - Increases/decreases the amount of delay time for Delay 1.

Middle Row - FILTER Q - Varies the bandwidth of the filter for Delay 1.

Top Row - MOD SOURCE - Determines what will be used as a modulator source - Oscillator choices, log control (the higher the signal the greater the amount of change) or MIDI controllers.

Knob 3 - Controls according to command line chosen:

Bottom Row - FEEDBACK - The amount of resonance for Delay 1. Creates repeats of the delayed signal.

Middle Row - DIFFUSION for the repeats in Delay 1. It blurs the repeats for realism.

Top Row - MOD DESTINATION - Designates what parameter is to be modulated.

Knob 4 - Controls according to command line chosen:

Bottom Row - MODULATION LEVEL - Sets the depth of the modulation. This is the global modulation level control for all modulators affecting Delay 1.

Middle Row - MIDI CLOCK SYNC - When using a MIDI clock to run the delay to sync echoes to bpm, this control allows you to designate note size as in eighth notes, quarter notes, quarter note triplets etc.

Top Row - MOD LEVEL - Individual depth control for Modulation modules 1 - 6.

Delay F/x
Machine

606

606 Delay F/x Machine

Knob 5 - Controls according to command line chosen:

Bottom Row - MIX - Varies the amount of wet/dry signal passing through Delay 2.

Middle Row - FILTER FREQUENCY - Adjusts the center frequency of the filter for Delay 2.

Top Row - OSCILLATOR RATE - Varies the rate of change for Modulation modules 1-6.

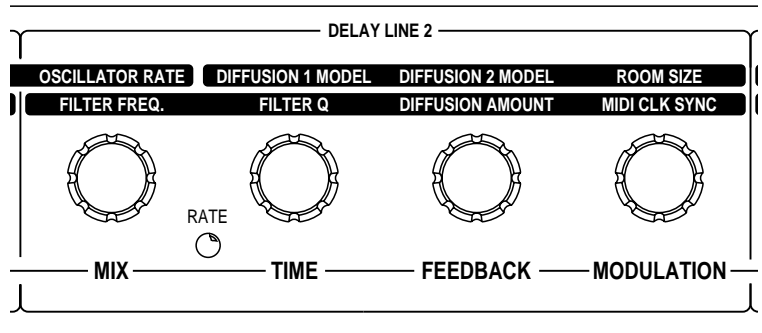

Knob 6 - Controls according to command line chosen:

Bottom Row - DELAY TIME - Increases/decreases the amount of delay time for Delay 2.

Middle Row - FILTER Q - Varies the bandwidth of the filter for Delay 2.

Top Row - DIFFUSION 1 MODEL - Designates model for the diffusion affecting Delay 1.

Knob 7 - Controls according to command line chosen:

Bottom Row - FEEDBACK - The amount of resonance for Delay 2. Creates repeats of the delayed signal.

Middle Row - DIFFUSION for the repeats in Delay 2. It blurs the repeats for realism.

Top Row - DIFFUSION 2 MODEL - Designates model for the diffusion affecting Delay 2.

Knob 8 - Controls according to command line chosen:

Bottom Row - MODULATION LEVEL - Sets the depth of the modulation. This is the global modulation level control for all modulators affecting Delay 2.

Middle Row - MIDI CLOCK SYNC - When using a MIDI clock to run the delay to sync echoes to bpm (beats per minute), this control allows you to designate note size as in eighth notes, quarter notes, quarter note triplets etc.

Top Row - ROOM SIZE - Active only when an ERL program is loaded. Parameter 69 activates ERL. The ROOM SIZE knob adjusts the reflections to match room description.

NOTE: It is normal for the 606 to take a second to update changes in ROOM SIZE.

Knob 9 - GLOBAL CONTROL - Controls according to command line chosen:

Bottom Row - GLOBAL OUTPUT LEVEL - Attenuates both outputs from single knob.

Middle Row - PARAMETER ADJUST - Permits adjustment to parameter choices from the PARAMETER SELECT.

Top Row - PARAMETER SELECT - Chooses which parameter you want to adjust. Once chosen, hit the SELECT button to go down to the second level and turn the same knob (GLOBAL) to adjust the parameter.

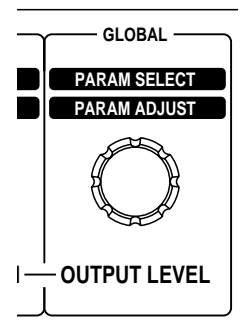

REAR PANEL

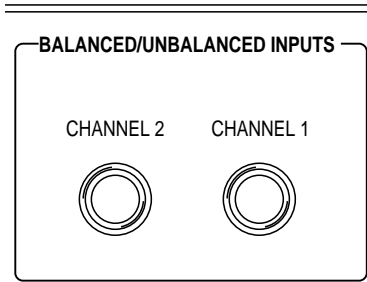

Inputs - Input Channel 1 - 1/4" TRS jack. The jack can be used balanced or unbalanced. Input Channel 2 - 1/4" TRS jack. See the drawing at the bottom of this page for correct wiring of connectors.

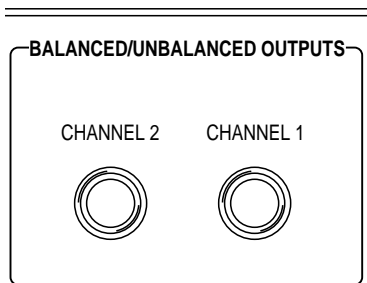

Outputs - Output Channel 1 - 1/4" TRS jack for signal output. Output Channel 2 - 1/4" TRS jack for signal output. See the drawing at the bottom of this page for correct wiring of connectors.

Footswitch - Tap Tempo footswitch. You may use either positive or negative style (normal open/normal close) momentary footswitches for changing and adapting delay times. The Tap Tempo's affect on the delay lines can be adjusted in Parameter 68.

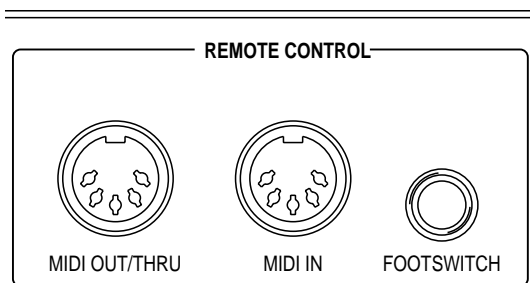

MIDI in - Accepts a MIDI cable for external control of parameters within the 606. MIDI channels for the 606 can be chosen through Parameter 78. Identifying an individual 606 among several for SysEx control can be performed using the MIDI unit number in Parameter 79. External control of Modulation modules from MIDI controllers is chosen by the MOD SOURCE knob.

MIDI out - Used to dump internal programs through SysEx for capture of presets. Pressing and holding the SELECT button will dump all the presets. Pressing the MODE button prior to pressing and holding the SELECT button will dump just the currently selected preset.

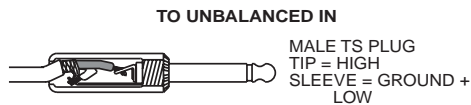
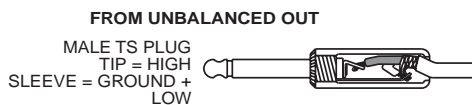
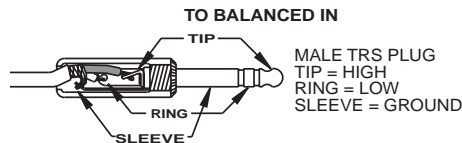
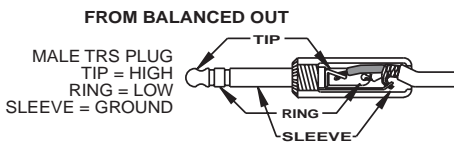
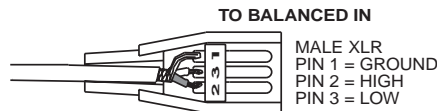
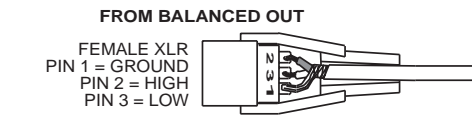

Delay F/x
 Machine
 606

AUDIO CONNECTIONS

For simplification purposes, it is assumed that you will be feeding the input(s) of the 606 from the effects send(s) of your mixer, and that you will be connecting the output(s) of the 606 to the effects return(s) on your mixer. You may also feed the 606 from other line-level devices, such as an electronic keyboard that provides line-level outputs, as illustrated on the next page. You may prefer to bring your effects returns back to your mixer on individual mixer channels, if your mixer has line-level channel inputs. You may be using the 606 as the final step in your recording chain, in which case the output(s) of the 606 would connect to the input(s) of your analog recorder. In any case, you should be able to apply the connection principals set forth below to your particular application.

There are three basic setups for the 606:

- 1) As two separate delay units (dual mono mode). For setup as two separate delay units, connect two separate effects sends from your mixer to the CHANNEL 1 and CHANNEL 2 Inputs, and connect the CHANNEL 1 and CHANNEL 2 Outputs to two separate effects returns on your mixer.
- 2) As a one-channel delay unit (Coupled mode). For example, when the output of Delay Line 1 is assigned to the input of Delay Line 2, using Parameters 20 and 21. For one-channel setup, connect the effects send from your mixer to the CHANNEL 1 Input. Connect the CHANNEL Output to the effects return on your mixer.

NOTE: *In this mode, the CHANNEL 1 Output is still active. You may wish to connect the CHANNEL 1 Output to a separate effects return on your mixer, for use as a separate delay tap.*

- 3) As a stereo delay unit (Coupled mode). This includes programs that use stereo left and right inputs and outputs, as well as programs that take a single input and generate stereo left and right outputs. For stereo delay setup, when you want stereo inputs and outputs, connect your stereo left effects send from your mixer to the CHANNEL 1 Input and connect your stereo right effects send from your mixer to the CHANNEL 2 Input. Connect the CHANNEL 1 Output to your stereo left effects return on your mixer, and connect the CHANNEL 2 Output to your stereo right effects return on your mixer.

For stereo delay setup, when you have a single (mono) input, and you want stereo outputs, connect your mono effects send from your mixer to the CHANNEL 1 Input. Connect the CHANNEL 1 Output to your stereo left effects return on your mixer, and connect the CHANNEL 2 Output to your stereo right effects return on your mixer.

Please see page 9 for Input/Output connector wiring information.

REMOTE CONTROL CONNECTIONS

The 606 has two types of remote control connections:

- 1) **MIDI:** The MIDI connections are two 5-pin DIN connectors labeled MIDI OUT/THRU and MIDI IN. Connect your MIDI source to the MIDI IN connector, and connect the MIDI OUT/THRU connector to the MIDI input of the next device that you wish to control via MIDI. Please see the information on MIDI Parameters 70, 71, 72, 78 and 79 in Chapter 6.
- 2) **FOOTSWITCH (Tap Tempo Input):** The second type of remote control connection is the footswitch connector, labeled FOOTSWITCH, which serves as the Tap Tempo Input. To use the tap tempo input of the 606, connect your footswitch to the ¼" footswitch input jack on the rear of the 606. You may use either a normally open or a normally closed footswitch. Please see the information on Parameter 68 in Chapter 10.

606 Delay F/x Machine

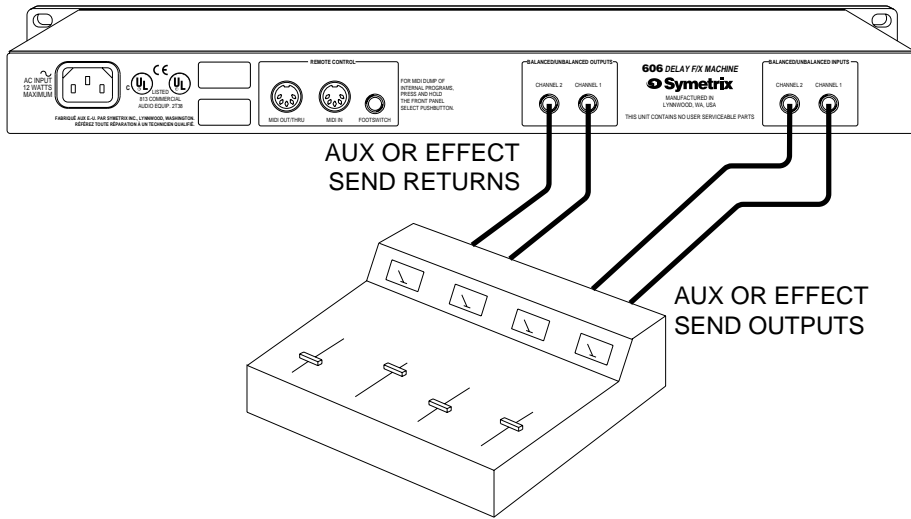

-DIAGRAM OF 606 SETUP FOR 2 SEPARATE DELAYS-

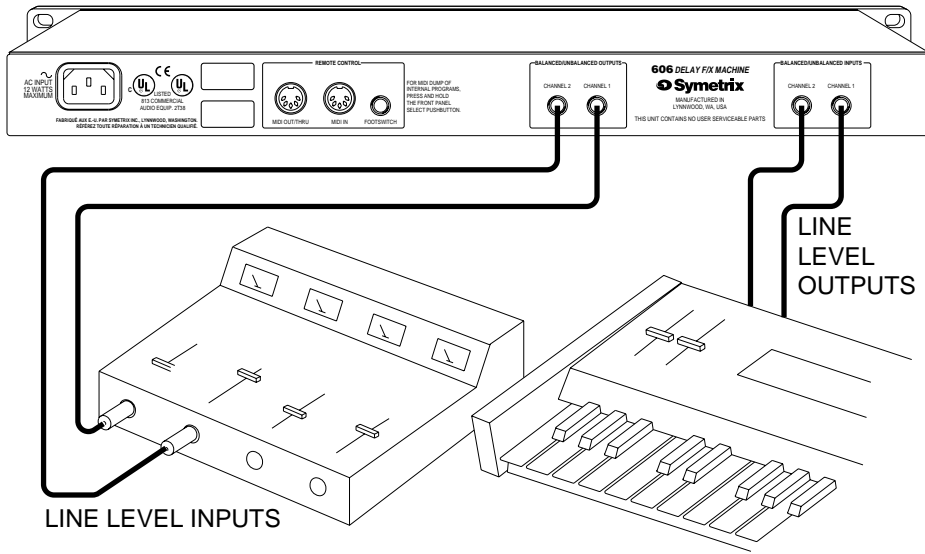

-DIAGRAM OF 606 WITH KEYBOARD AND MIXER-

606 Delay F/x Machine

EASIEST: THE 606 AS A SIMPLE 2-CHANNEL DELAY

The easiest mode of operation is described in the Fast Setup section. In this mode, load the preset “2CH”, which configures the 606 as a dual delay unit, and then use the bottom Command Line of the 606. DELAY LINE 1 will be accessed through the CHANNEL 1 INPUT and CHANNEL 1 OUTPUT jacks, and will be controlled by the DELAY LINE 1 controls. DELAY LINE 2 will be accessed through the CHANNEL 2 INPUT and CHANNEL 2 OUTPUT jacks, and will be controlled by the DELAY LINE 2 controls.

For the this level of operation, use the Command Line 1 parameter adjustment controls:

MIX To adjust the balance between dry (non-delayed) and delayed signal at the output of each delay line.

TIME To adjust length of delay time for each delay line.

FEEDBACK To adjust the amount of feedback (repeats) at the output of each delay l.

MODULATION This control should be set to “0” for basic delay effects.

This level of operation provides two independent channels of delay, and the ability to make quick, “on the fly” delay time adjustments required by live sound reinforcement applications. This level is also well-suited to installations where many people will be using the unit, with little or no time for training.

MORE ADVANCED: USING THE WIDE ARRAY OF 606 PRESETS

For more advanced operation, you can load any of the 109 presets that are factory installed in the 606. These presets cover a wide range of applications, and chances are good that you will find one that suits your needs. Please see Chapter 7 for an in-depth discussion of the 606’s presets, and Appendix D for a quick reference list of these presets. Presets that route the output of one delay line into the input of the other delay line (such as “1CH” and “P20”) will require that you connect your effects send to the appropriate 606 channel input, and that you connect your effects return(s) to the appropriate 606 channel output(s).

This level of operation is also well suited to live sound reinforcement applications, as long as you are correctly patched for the presets that you select. With the 606, you have the ability to recall the next preset that you want to use, while the currently loaded preset remains active. Then, when you want to load the new preset, you simply press and hold the LOAD button in for about one second.

VERY ADVANCED: CREATING YOUR OWN 606 EFFECTS

Welcome to the “Power User” level, where you get to have some real fun. This advanced level of operation allows you to use the presets and parameters to make full use of the extreme flexibility of the 606. This level of operation is also more time-consuming and technically involved than either of the two levels listed above, so it is most useful for situations where you have some time to experiment with the unit. You can save your results to any of the first ninety-nine preset locations, to be instantly recalled at a later time.

The 606 is shipped with the Building-Block Presets, which are stored in permanent preset locations 100-109, and also copied into preset locations 1-9. Preset locations 1-9 make good starting points and good working locations for writing your own presets. If you end up with something totally unusable, you can always reload the Building-Block Preset that you started with, and begin again. Please see Chapter 7 for an in-depth discussion of the 606’s presets, and Appendix D for a quick reference list of these presets.

The 606 has eighty parameters which can be adjusted to create almost limitless effects variations. These parameters are discussed in-depth in Chapter 10. A quick reference list of these parameters can be found in Appendix C and on the laminated 606 Preset Chart/Flowchart that came with your 606.

606 Delay F/x Machine

A full complement of 109 factory presets have been pre-programmed into the 606 for immediate access and fast first-time setup. There are ten non-erasable presets, in locations 100-109, that are the Building-Block Presets. These are for you to use when making your own presets. The 606 is shipped from the factory with these ten Building-Block Presets also copied into preset locations 1-9. The presets in preset locations 1-99 are yours to use as-is or to modify. If you wish to create your own preset, you may start from scratch with one of the Building-Block Presets, or you may find the factory preset that is closest to the effect you want, and then modify this preset to conform to your desired sound. Please see Appendix D for a complete list of presets for the Symetrix 606.

PRESETS 1-9 (BUILDING-BLOCK PRESETS)

The non-erasable Building-Block Presets found in preset locations 100-109 are also copied into preset locations 1-9. The copied building-block presets in locations 1-9 are erasable. These first nine preset locations make good starting points and good working locations for writing your own presets. If you end up with something totally unusable, you can always reload the Building-Block Preset that you started with, and start over again. Connections to and from the 606 will be determined by the type of Building Block Preset that is selected. Please see the following description of Presets 100-109, for a more detailed description of each of the Building Block Presets.

PRESETS 10-19 (DUAL MONO - 2 CHANNEL PRESETS)

These presets use the 606 as two separate delay line processors. Delay Line 1 and Delay Line 2 can share modulation sources, but the audio signal path of Delay Line 1 will not be mixed with the audio signal path of Delay Line 2 in a Dual Mono Preset.

Typically, you would wire this setup to your mixing console as if you were using two separate pieces of gear. Run separate effects (or auxiliary) sends to the CHANNEL 1 and CHANNEL 2 Inputs, and separate effects (or auxiliary) returns from the CHANNEL 1 and CHANNEL 2 Outputs. An example of using the 606 as two separate delay lines would be: setting Delay Line 1 to apply a flanger effect to an electric piano, and setting Delay Line 2 to add a doubling effect to vocals.

PRESETS 20-29 (1-CHANNEL PRESETS)

These presets are complex programs, or “multi-effect” programs, which use the CHANNEL 1 Input and the CHANNEL 2 Output. An example of a complex or “multi-effect” program would be: feeding the audio signal through a flanger program on DELAY LINE 1, then through an echo program on DELAY LINE 2, to create a “sweeping echo” effect at the CHANNEL 2 Output.

Typically, you would connect your mixing console’s effects (or auxiliary) send to the CHANNEL 1 Input, and connect the CHANNEL 2 Output to your mixing console’s effects (or auxiliary) return. Because the CHANNEL 1 Output remains active in these programs, you may decide that you want to connect both the CHANNEL 1 Output and the CHANNEL 2 Output to effects (or auxiliary) returns on your mixing console, for an even greater number of effects possibilities.

Some of these presets, such as 20 and 21, feed the output of DELAY LINE 1 to the input of DELAY LINE 2. Other presets, such as 23 and 24, feed the dry signal at the CHANNEL 1 Input to the inputs of both DELAY LINE 1 and DELAY LINE 2, and then route the DELAY LINE 1 and DELAY LINE 2 Outputs to the CHANNEL 2 Output.

PRESETS 30-39 (COUPLED PRESETS)

These presets, found in locations 30-39, have separate CHANNEL 1 and CHANNEL 2 Input and Output connections, but the audio paths of DELAY LINE 1 and DELAY LINE 2 are mixed, at least partially, at some point between the CHANNEL 1 and CHANNEL 2 Input and Output connections. An example of the audio paths mixing is: a preset such as Preset 30, which sends a mixture of about 80% CHANNEL 1 Input signal and about 20% CHANNEL 2 Input signal to the input of DELAY LINE 1, and sends a mixture of about 20% CHANNEL 1 Input signal and about 80% CHANNEL 2 Input signal to the input of DELAY LINE 2. Another example would be: a preset such a Preset 35, which routes the DELAY LINE 1 feedback signal to the inputs of both

Delay F/x
Machine

606

DELAY LINE 1 and DELAY LINE 2, with DELAY LINE 1 receiving a large portion of the feedback signal, and DELAY LINE 2 receiving a smaller portion of the feedback signal. Preset 35 also routes the DELAY LINE 2 feedback signal to the inputs of both DELAY LINE 1 and DELAY LINE 2, with DELAY LINE 2 receiving a large portion of the feedback signal, and DELAY LINE 1 receiving a smaller portion of the feedback signal.

Typically, you would connect your mixing console's stereo effects (or stereo auxiliary) send to CHANNEL 1 Input and CHANNEL 2 Input and connect the CHANNEL 1 Output and CHANNEL 2 Output to your mixing console's stereo effects (or auxiliary) return. If your console does not have stereo effects sends and returns, then two separate effects sends and effects returns may be used.

These COUPLED presets can easily be turned into DUAL MONO presets by pressing the MODE button. The DUAL MONO LED should light when you press the MODE button, indicating that all audio path ties between the DELAY LINE 1 and DELAY LINE 2 have been severed.

PRESETS 40-49 (FLANGERS)

These presets include both DUAL MONO and COUPLED flanger presets. Flanging is typically used to create a "comb filter" sound, a special effect which is often applied to drum and guitar sounds. Connect the inputs and outputs of the 606 in a manner appropriate to the type of preset (DUAL MONO or COUPLED) that has been loaded.

PRESETS 50-59 (SINGLE-FEED STEREO PRESETS)

These presets take a single input (CHANNEL 1 Input) and generate stereo outputs (CHANNEL 1 and CHANNEL 2 Outputs). Connect the effects send from your mixing console to the CHANNEL 1 Input, and connect the CHANNEL 1 and CHANNEL 2 Outputs to the stereo effects return on your console.

PRESETS 60-79 (VARIOUS EFFECTS)

These presets represent some of the many effects possibilities that the 606 can perform. These presets all couple DELAY LINE 1 and DELAY LINE 2 in some way. Many of these presets, such as Preset 60, use one of the modulation modules to apply a triangle wave to the DELAY LINE 1 Wet Pan and to the DELAY LINE 2 Wet Pan, to make the outputs of DELAY LINE 1 and DELAY LINE 2 appear to move back and forth between the speakers. To use these presets, connect the stereo effects send of your mixing console to CHANNEL 1 Input and CHANNEL 2 Input. Connect CHANNEL 1 Output and CHANNEL 2 Output to the stereo effects return of your mixing console.

PRESETS 80-89 (ERL-ROOM SIMULATIONS)

These are room simulation presets created using the 606's ERL (EARLY REFLECTIONS MODULE). The ERL considers the CHANNEL 1 and CHANNEL 2 Inputs to be a single source, so you can connect your signal source to either input, or both. For best results, insert the 606 in the signal path of the audio signal that you wish to route through the ERL. This is preferable to using your console's effects sends and returns, because you do not want to mix the dry signal back in, as the dry signal would not have the same aural room placement as the audio that has been processed by the ERL module.

The CHANNEL 1 and CHANNEL 2 Outputs should be connected in stereo for the best aural room placement. If you routed the output of your console to the input(s) of the 606, connect the CHANNEL 1 Output of the 606 to the left channel input of the device that follows the 606, and connect the CHANNEL 2 Output of the 606 to the right channel input of the device that follows the 606. If you used a channel insert point on your mixing console to send the desired audio signal to the input(s) of the 606, then connect the 606's CHANNEL 1 and CHANNEL 2 Outputs to a stereo input on your mixing console, or return these outputs to two separate mixer channels. If you return through two separate mixer channels, pan the mixer channel connected to the 606's CHANNEL 1 Output to the left, and pan the mixer channel connected to the 606's CHANNEL 2 Output to the right.

PRESETS 90-99 (REVERB SIMULATIONS)

These are stereo simulations of the reverberation that would be developed by applying the audio signal to various environments. Both inputs are applied equally to both delay lines, so you may connect just one of your mixer's effects sends to either the 606's CHANNEL 1 Input or CHANNEL 2 Input, or you may connect a stereo effects send to the 606's CHANNEL 1 and CHANNEL 2 Inputs. The outputs of these simulations are stereo, so the 606's CHANNEL 1 and CHANNEL 2 Outputs should be connected to a stereo effects return on your mixer, or returned to two separate mixer channels, which are panned left and right.

PRESETS 100-109 (BUILDING-BLOCK PRESETS)

Locations 100-109 are the only non-erasable (ROM) preset locations. The Building-Block Presets that are loaded into these locations, and also copied into locations 1-9, are meant to be the starting point for writing your own programs as well as a starting point for live sound reinforcement use. The following is an in-depth discussion of each of the Building-Block Presets.

LOCATION 100 2CH 2-CHANNEL PROGRAM (DUAL MONO)

This preset configures the 606 as two separate delay line processors. The CHANNEL 1 Input is routed to DELAY LINE 1, which is routed to the CHANNEL 1 Output. The CHANNEL 2 Input is routed to DELAY LINE 2, which is routed to the CHANNEL 2 Output. The FOOTSWITCH Input (for use as a Tap Tempo Input) will be activated if a footswitch was connected to the FOOTSWITCH jack, on the rear of the 606, when the 606 was powered up. Connect separate effects (or auxiliary) sends to the CHANNEL 1 and CHANNEL 2 Inputs, and separate effects (or auxiliary) returns from the CHANNEL 1 and CHANNEL 2 Outputs.

LOCATION 101 1CH 1-CHANNEL PROGRAM

This preset internally configures the 606 with the output of DELAY LINE 1 routed to the input of DELAY LINE 2. This allows one delay effect to be fed to a second delay effect. This configuration also provides the longest possible delay length for the 606 (in conjunction with setting Parameter 69 for 16-bit resolution). Connect the effects send from your mixing console to the CHANNEL 1 Input, and connect the CHANNEL 2 Output to your mixing console's effects return. In this mode, the output of DELAY LINE 1 is also routed to the CHANNEL 1 Output, so you may also wish to connect the CHANNEL 1 Output to a second effects return on your mixing console, for even greater effects options. The FOOTSWITCH Input (for use as a Tap Tempo Input) will be activated if a footswitch was connected to the FOOTSWITCH jack, on the rear of the 606, when the 606 was powered up.

LOCATION 102 STE STEREO PROGRAM (COUPLED)

This preset routes both the CHANNEL 1 and CHANNEL 2 Input signals to the input of DELAY LINE 1, with the CHANNEL 1 Input signal in a greater proportion (approximately 80%) than the CHANNEL 2 Input signal (approximately 20%). This preset also routes both the CHANNEL 1 and CHANNEL 2 Input signals to the input of DELAY LINE 2, with the CHANNEL 2 Input signal in a greater proportion (approximately 80%) than the CHANNEL 1 Input signal (approximately 20%). Stereo (or separate) effects sends from your mixing console should be connected to the CHANNEL 1 and CHANNEL 2 Inputs, and stereo (or separate) effects returns to your mixing console should be connected to the CHANNEL 1 and CHANNEL 2 Outputs. Pressing the MODE button once would force the two delay lines into DUAL MONO MODE, completely separating DELAY LINE 1 and DELAY LINE 2 (the CHANNEL 1 Input and Output connections would only be connected to DELAY LINE 1, and the CHANNEL 2 Input and Output connections would only be connected to DELAY LINE 2). Pressing the MODE button once more would restore the preset to COUPLED MODE.

LOCATION 103 1-2 SINGLE-FEED STEREO PROGRAM

This preset routes the CHANNEL 1 and CHANNEL 2 Input signals, in equal proportions, to the inputs of DELAY LINE 1 and DELAY LINE 2. This allows you to generate stereo effects from just one input signal, applied to either the CHANNEL 1 or CHANNEL 2 Input. Connect your mixing

Delay F/x
Machine

606

console's effects send to either the CHANNEL 1 or the CHANNEL 2 Input, whichever you prefer, and connect the CHANNEL 1 and CHANNEL 2 Outputs to a stereo effects return on your mixing console.

LOCATION 104 FLG FLANGER

This stereo preset is used to create flange programs by modulating the TIME and FILTER FREQ. parameters of DELAY LINE 1 and DELAY LINE 2. Connect a stereo effects send from your mixing console to the CHANNEL 1 and CHANNEL 2 Inputs, and connect the CHANNEL 1 and CHANNEL 2 Outputs to a stereo effects return on your mixing console. The DELAY TIME, MOD LEVEL and FEEDBACK controls can be adjusted to change the character of the sound.

LOCATION 105 CHO CHORUS

This single-feed stereo preset is a building block to create your own chorusing programs. Chorusing is an effect similar to flanging, used to make one instrument sound like several. Chorusing is created by modulating the TIME and Dry Output Pan parameters of DELAY LINE 1 and DELAY LINE 2. Connect an effects send from your mixing console to either the CHANNEL 1 or CHANNEL 2 Input, and connect the CHANNEL 1 and CHANNEL 2 Outputs to a stereo effects return on your mixing console.

LOCATION 106 FBK COUPLED FEEDBACK

This stereo preset routes the DELAY LINE 1 feedback signal to the input of DELAY LINE 2, and routes the DELAY LINE 2 feedback signal to the input of DELAY LINE 1. This preset also modulates the TIME and Wet Output Pan parameters for DELAY LINE 1 and DELAY LINE 2. Connect a stereo effects send from your mixing console to the CHANNEL 1 and CHANNEL 2 Inputs, and connect the CHANNEL 1 and CHANNEL 2 Outputs to a stereo effects return on your mixing console.

LOCATION 107 PAN COUPLED OUTPUTS

This stereo preset modulates the Wet Output Pan parameter of DELAY LINE 1 and DELAY LINE 2, so that the outputs of both delay lines are panned back and forth between the CHANNEL 1 Output and the CHANNEL 2 Output. Connect a stereo effects send from your mixing console to the CHANNEL 1 and CHANNEL 2 Inputs, and connect the CHANNEL 1 and CHANNEL 2 Outputs to a stereo effects return on your mixing console.

LOCATION 108 ERL ROOM SIMULATION

This single-feed stereo preset loads the Early Reflections Module (room simulation program), which allows you to aurally place the sound source and listener within a simulated room. Connect an effects send from your mixing console to either the CHANNEL 1 or CHANNEL 2 Input, and connect the CHANNEL 1 and CHANNEL 2 Outputs to a stereo effects return on your mixing console.

NOTE: Due to the large calculation for the reflections in a room, the 606 will take a few seconds to load the ERL preset, and to effect changes that you have performed to the simulated room. Allow the moving dot appearing in the display to stop before you listen to check your adjustments.

LOCATION 109 RVB REVERB

This single-feed stereo preset turns the 606 into a reverb simulator. The ROOM SIZE control selects the type of reverb (from small room to concert hall), and Parameter 66 sets the simulated reflectivity. Connect an effects send from your mixing console to either the CHANNEL 1 or CHANNEL 2 Input, and connect the CHANNEL 1 and CHANNEL 2 Outputs to a stereo effects return on your mixing console.

NOTE: Due to the large calculation for the reverb simulation, the 606 will take a few seconds to load the Reverb preset, and to effect changes that you make to this preset. Allow the moving dot appearing in the display to stop before you listen to check your adjustments.

MODIFYING FACTORY PRESETS

To modify one of the 606's Factory Presets, you will first need to load the factory preset that you wish to modify. This is accomplished by selecting the desired preset with the PRESET control, then pressing and holding in the LOAD button, until the preset name in the LED window display flashes and then comes on solidly.

At this point, the preset has been loaded, unless you are loading a preset that requires a lot of math calculations. If you are loading a preset which uses a large program requiring many calculations, such as any preset using the Early Reflections Module, the preset name will flash and then come on solidly, but you will also see a decimal point "walk" across the LED window display for a few seconds. The "walking" decimal point indicates that the math calculations are still being made. When the "walking" decimal point disappears, the preset has finished loading.

Now, you can select the first parameter that you wish to modify. Please refer to Chapter 10 for a complete description of the parameters, or to the quick reference chart of 606 Parameters (located in Appendix C of this manual and also on the laminated Parameter Chart/Flowchart that came with your 606). Press the SELECT button until the LED that indicates the Top Command Level lights. Then, use the PARAM SELECT control (the far right knob on the front panel) to select the parameter that is to be modified.

When you have selected this parameter, press the SELECT button once to get to the Middle Command Level (the LED that indicates the Middle Command Level should light). You can now adjust the selected parameter, using the PARAM ADJUST control (the far right knob on the front panel). Repeat this process to adjust any other parameters that you wish to change.

If you do not wish to save your modified preset, do not press the SAVE button. If you wish to return to the original preset, this can be accomplished by reloading the original preset, or by powering down, and then back up. If you prefer, you can load a different preset. If you load another preset, and then return later to the preset that you were modifying, you will get the original preset (not the modified preset).

If you want to save this modified preset, pressing and holding in the SAVE button at this point will overwrite the original preset with your modified preset. If "Prt" appears in the LED window display, you either started with one of the non-erasable presets in Preset Locations 100-109, or Parameter 80 (Memory Protect) is turned on.

If you started with one of the non-erasable presets, you will need to save your modified preset to a different Preset Location. If the Memory Protection is turned on, and you wish to override it, go to the Top Command Level, using the SELECT button, and select Parameter 80 with the PARAM SELECT control. Then, go to the Middle Command Level, using the SELECT button, and turn the PARAM ADJUST control until the LED display window reads "OFF". You will now be able to overwrite the original preset.

If you want to save your modified preset to a different location, and you want to preserve the original preset, adjust the PRESET control so that the name of the Preset Location that you wish to overwrite appears in the LED window display. Then, press and hold in the SAVE button, until the preset name in the LED window display flashes once, and then comes on steadily. You have now saved your modified preset to the Preset Location that you selected with the PRESET control. You can name your modified preset, if you wish, by using Parameters 75-77. Otherwise, the name of the preset will be the Preset Location where it is stored (for example: P20, which would be the preset stored at Preset Location 20).

To name your modified preset, go to the Top Command Level, using the SELECT button, and select Parameter 75 with the PARAM SELECT control. Then, go to the Middle Command Level, using the SELECT button, and turn the PARAM ADJUST control to select the first character of the modified preset name. Repeat this process, using Parameter 76 to select the second character, and Parameter 77 to select the third character, of the name of your modified preset.

Delay F/x
Machine

606

606 Delay F/x Machine

NOTE: *It is recommended that you use Preset Locations 1-9 to store your modified presets. The 606 is shipped from the factory with the Building Block Presets, which are stored in the 606's permanent memory at Preset Locations 100-109, also copied into Preset Locations 1-9. Therefore the presets stored in Preset Locations 1-9 are duplicates of the Presets stored in Preset Locations 100-109.*

CREATING YOUR OWN PRESETS

To create your own 606 preset, we recommend that you first load the Building Block Preset (Preset Locations 100-109) that is appropriate for your application, or else load the factory preset that is closest to the effect that you wish to achieve. To start from scratch load one of the first four Building Block Presets (2CH, 1CH, Ste and 1-2), depending on the input/output configuration that you want your new preset to have. To load a preset, select the desired preset with the PRESET control, then press and hold in the LOAD button, until the preset name in the LED window display flashes and then comes on solidly.

At this point, the preset has been loaded, unless you are loading a preset that requires a lot of math calculations. If you are loading a preset which uses a large program requiring many calculations, such as any preset using the Early Reflections Module, the preset name will flash and then come on solidly, but you will also see a decimal point “walk” across the LED window display for a few seconds. The “walking” decimal point indicates that the math calculations are still being made. When the “walking” decimal point disappears, the preset has finished loading.

Now, you can select the first parameter that you wish to modify. Please refer to Chapter 10 for a complete description of the parameters, or to the quick reference chart of 606 Parameters (located in Appendix D of this manual and also on the laminated Parameter Chart/Flowchart that came with your 606). Press the SELECT switch until the LED that indicates the Top Command Level lights. Then, use the PARAM SELECT control (the far right knob on the front panel), to select the parameter that is to be modified.

When you have selected this parameter, press the SELECT switch once to get to the Middle Command Level (the LED that indicates the Middle Command Level should light). You can now adjust the selected parameter, using the PARAM ADJUST control (the far right knob on the front panel). Repeat this process to adjust any other parameters that you wish to change.

If you do not wish to save your new preset, do not press the SAVE button. If you wish to return to the original preset, this can be accomplished by reloading the original preset, or by powering down, and then back up. If you prefer, you can load a different preset. If you load another preset, and then return later to the preset that you were modifying, you will get the original preset (not the modified preset).

If you want to save your new preset, pressing and holding in the SAVE button at this point will overwrite the original preset with your modified preset. If “Prt” appears in the LED window display, you either started with one of the non-erasable presets in Preset Locations 100-109, or Parameter 80 (Memory Protect) is turned on.

If you started with one of the non-erasable presets, you will need to save your new preset to a different Preset Location. If the Memory Protection is turned on, and you wish to override it, go to the Top Command Level, using the SELECT button, and select Parameter 80 with the PARAM SELECT control. Then, go to the Middle Command Level, using the SELECT button, and turn the PARAM ADJUST control until the LED display window reads “OFF”. You will now be able to overwrite the original preset.

If you want to save your new preset to a different location, and to preserve the original preset, adjust the PRESET control so that the name of the Preset Location that you wish to overwrite appears in the LED window display. Then, press and hold in the SAVE button, until the preset name in the LED window display flashes once, and then comes on steadily. You have now saved your modified preset to the Preset Location that you selected with the PRESET control.

You can name your new preset, if you wish, by using Parameters 75-77. Otherwise, the name of the preset will be the Preset Location where it is stored (for example: P20, which would be the preset stored at Preset Location 20).

To name your new preset, go to the Top Command Level, using the SELECT button, and select Parameter 75 with the PARAM SELECT control. Then, go to the Middle Command Level, using the SELECT button, and turn the PARAM ADJUST control to select the first character of the new preset name. Repeat this process, using Parameter 76 to select the second character, and Parameter 77 to select the third character, of the name of your new preset.

NOTE: It is recommended that you use Preset Locations 1-9 to store your new presets. The 606 is shipped from the factory with the Building Block Presets, which are stored in the 606's permanent memory at Preset Locations 100-109, also copied into Preset Locations 1-9. Therefore the presets stored in Preset Locations 1-9 are duplicates of the Presets stored in Preset Locations 100-109.

606 Delay F/x Machine

 DELAY MODULE

Most musical sounds can benefit from a slight bit of delay to fatten the sound and to add life or ambience to the sound. Short delay times are useful for doubling, chorusing, flanging and reverb effects. Longer delay times are useful for echo effects such as slapback and long, repeating echoes. The Delay Module parameters are: Dry/Wet Mix, Delay Time, Feedback Amount, and Delay Source.

The MIX front panel controls (or Parameters 1 and 4) will determine how much of the delayed signal you will hear at the output of the 606. If you are connecting the 606 to the effects sends and returns of a mixing console, you will probably want to set the MIX controls to “100” (100% “wet” signal) on both delay lines. You will then be able to balance the “wet/dry” (delayed signal/non-delayed signal) mix using the effects return master control on your mixing console for the “wet” signal level control, and the channel faders or potentiometers for the “dry” signal level control.

The TIME front panel controls (or Parameters 1 and 5) for DELAY LINE 1 and DELAY LINE 2 allow you to adjust the length of delay. The length of delay is also affected by Parameter 69 (memory width). Setting the memory width to “24” gives you 24-bit memory resolution, and a maximum delay length, per delay line, of 1.35 seconds. Setting the memory width to “16” gives you a maximum delay length, per delay line, of 2.74 seconds, with 16-bit resolution. When MIDI control is being used, Parameters 70 and 71 will adjust the delay length.

The FEEDBACK front panel controls (or Parameters 2 and 6) allow you to repeat the delayed signals. If the feedback level is set lower than the dry input signal level, then the echoes will slowly die out. If the feedback level is set at the same level as the dry input signal, then the echoes will continue at the same level. If the feedback level is set higher than the dry input signal level, the echoes will build in level, until you have runaway feedback. You will probably want to avoid this last scenario.

For two separate delay lines, run the 606 in DUAL MONO mode and connect the inputs and outputs of CHANNEL 1 and CHANNEL 2 to separate effects sends and returns. To use the 606 as a single delay line, run the 606 in COUPLED mode, routing the output of DELAY LINE 1 to the input of DELAY LINE 2. For a single delay line, connect your effects send to the CHANNEL 1 Input, and your return to the CHANNEL 2 Output. Use the Delay Source parameters (Parameters 11 and 21) to route the desired signal to the input of each delay line.

NOTE: *For simple delay effects, the MODULATION controls (or Parameters 3 and 7) should be set to zero. If you do want to modulate your delay effect, please read the MODULATION MODULE section of this chapter.*

 FILTER MODULE

The 606 uses a 20-bit A/D and D/A, so the quality of the delayed sound is remarkably like the original signal. Instead of sounding like a natural echo, the delayed signal could be mistaken for a note that was hit twice. In some cases, it will be desirable for the delayed signal to sound exactly like the original signal, but if you want to create the effect of natural echo, you will need to use some delay feedback and filtering.

To imitate natural echoes, filter off the high frequencies of the delayed signal. If you are using delay feedback, each time the signal is fed back through the delay line, more signal will be removed at the frequencies that are being filtered. This simulates the faster absorption of high frequencies relative to low frequencies that occurs with natural echoes.

The filters on the 606 can also function in other ways. For example, the filters can be used to create wahwah-type effects or synthesizer-type sounds.

The 606 filter parameters are: Filter Type, Filter Frequency and Filter Q.

The Filter Type parameters (Parameters 13 and 23) are used to select low-pass, band-pass,

606 Delay F/x Machine

notch or high-pass as the type of filter that you will be using. Low-pass filters pass the frequencies below their specified cutoff frequency, and are useful for filtering out high frequencies, as in the natural echo effect described above. Band-pass filters have both a high-pass and low-pass filter, and they pass all of the frequencies in between the cutoff frequencies for their high-pass and low-pass filters. Notch filters are used to remove a specific frequency with minimal filter effect on the neighboring frequencies. Notch filters will help if you have a problem frequency that threatens to feedback, or that you simply don't like. High-pass filters pass the frequencies above their specified cutoff frequency, and are useful for removing rumble or other low-frequency sounds that you find objectionable.

The FILTER FREQ. front panel controls (or Parameters 14 and 24) select the cutoff-frequency if your filter type is high-pass or low-pass, and the center frequency if your filter type is band-pass or notch.

The FILTER Q front panel controls (or Parameters 15 and 25) select the Q of your filter. The filter Q setting determines what the bandwidth of the filter will be (Q is the inverse of bandwidth). For a very narrow (notch) filter, you will want to use a high Q setting. For a wide (band-pass) filter, you will need to use a low Q setting.

If you have selected a notch filter with a very high Q, you may have difficulty hearing its effect. You can temporarily widen the bandwidth to make the effect more obvious, so that you can verify that the filter is active.

NOTE: Filter Type choices LPI and HP1 do not allow a change in Q width, so if you try to adjust the Q width when one of these filters is selected, the LED display will read “--”, indicating that the parameter you are attempting to modify cannot be changed.

DIFFUSION MODULE

Reverberation is not to be confused with echoes. Echoes are sound reflections that occur at time intervals which are long enough that the human ear can discern the discrete repetitions of the original signal. A sound reflection has to occur at least 50 milliseconds after the original signal in order for the human ear to hear a distinct echo. Reflections shorter than this would be reverberation.

Natural reverberation, which occurs in most indoor spaces, is characterized by sound waves reflecting off the hard, reflective surfaces of the space. These reflections occur at very short time intervals, too short for the human ear to discern the individual reflections. The diffused reflections blend together to create a “wall of reverb”. The surfaces that bounce the sound waves around can be the walls, ceiling, floor, windows, mirrors, tabletops, and any other reflective surfaces.

NOTE: The earliest reflections are dealt with separately, in the 606's Early Reflections Module. These early reflections, which are too short for the human ear to discern as reverb, are used by the human ear to locate the sound source.

As time passes, more and more reflections are generated (the amount of signal diffusion increases), so the spacing between individual sound reflections is decreased, causing a “blurring” effect, and the resulting blend of reflections decays in volume and frequency response. This decaying of sound is caused by lost energy every time the sound reflects off a surface as some of the energy is absorbed by the surface each time that there is an impact. Different audio frequencies are absorbed at different rates, depending on the absorption properties of the each surface in the environment with which you are dealing.

Large indoor environments with many hard, reflective surfaces will exhibit a very dense reverberation field, with a very long decay time. Small rooms with very absorptive surfaces, and no reflective surfaces will exhibit a very sparse reverberation field, with a very short decay time (the reverb would be so slight that it would be impossible to hear).

The 606's Diffusion Module electronically creates the short reflections that would occur in natural reverberation. The Diffusion Module parameters are Diffusion Amount and Diffusion Model.

Delay F/x Machine 606

The DIFFUSION 1 MODEL front panel control (or Parameter 73) selects the indoor space size that the DELAY LINE 1 diffusion model will emulate (in other words, the size of the reverberation field). If you select a small indoor space size (Sn1 or Sn2), you will get the minimum rate of reverberation decay (the reverberation will decay quickly). If you select a larger indoor space size (Lg1 or Lg2), you will get the maximum rate of reverberation decay (it will decay slowly). If you select a medium indoor space size (NE1 or NE2), the rate of reverberation decay will fall somewhere between maximum and minimum.

The DIFFUSION 2 MODEL front panel control (or Parameter 74) is the same as above, except that it selects the indoor space size that the DELAY LINE 2 diffusion model will emulate.

The DIFFUSION AMOUNT controls for DELAY LINE 1 and DELAY LINE 2 (or Parameters 48 and 49), adjust the density of the sound reflections for the respective delay lines' diffusion models. The maximum diffusion amount is obtained by setting the diffusion amount parameter to "16", which simulates a very reflective environment. Setting the diffusion amount parameter to "16" would result in a thicker, blurred reverberation sound. The minimum diffusion amount is obtained by setting this parameter to "OFF", which simulates an absorptive environment. Setting this parameter to "OFF" would give you a cleaner, sparser reverberation sound.

EARLY REFLECTIONS MODULE

You are able to locate the source of sounds occurring in your vicinity because your ears receive sound placement cues from early sound reflections. These placement cues are processed by your brain, to pinpoint the location of the sound source.

The 606's Early Reflections Module (ERL module) generates these cues before the sound even reaches your ears, to give you sound placement information. The Early Reflections Module does this by creating a "virtual room", in which you are allowed to define many aspects: sound source placement, listener placement size of room, reflectivity of the walls and even the distance between the listener's ears.

To activate this room simulation module, you must either load one of the ERL presets (Presets 80-89), or you must engage the ERL module using Parameter 69 (Memory Width).

The ERL parameters are Room Size, Early Reflection Tap Attenuation, Signal Source L/R, Signal Source F/R, Listener Location L/R, Listener Location F/R, Reflection Coefficient, Ear Width and Memory Width.

NOTE: *The 606's ERL module is extremely powerful, but as a result of the large number of calculations required for each room parameter change, it takes a few seconds for the unit to calculate room dimensions and ray traces for proper reflections. While the calculations are occurring, you will see a decimal point "walk" across the LED Window Display. Be sure to wait for the decimal point to stop "walking" before you listen to check any parameter changes that you have made.*

The ROOM SIZE front panel control (or Parameter 60) selects the size of the "virtual room" that will be simulated by the Early Reflections Module. The choices range from a small (19.4x22x15.4-ft.) room to a large (122.4x49x58.7-ft.) hall.

The Early Reflection Tap Attenuation parameter (Parameter 61) controls attenuation of the ERL Module's output level. This is variable from "inf" (off) to "0" (unity gain).

The Signal Source L/R parameter (Parameter 62) allows you to choose the apparent left-to-right position of the omnidirectional sound source in the room simulation, in relation to the listener.

The Signal Source F/R parameter (Parameter 63) allows you to choose the apparent front-to-rear position of the omnidirectional sound source in the room simulation, in relation to the listener.

606 Delay F/x Machine

The Listener Location L/R parameter (Parameter 64) allows you to choose the apparent left-to-right position of the listener in the room simulation.

The Listener Location F/R parameter (Parameter 65) allows you to choose the apparent front-to-rear location of the listener in the room simulation.

The Reflection Coefficient parameter (Parameter 66) allows you to choose the reflectivity of the walls in the room simulation.

The Ear Width parameter (Parameter 67) allows you to choose the distance between the ears of the listener, in the room simulation.

The Memory Width parameter (Parameter 69) must be set to “ERL” for the Early Reflections Module to be engaged. Loading any one of the ERL Presets (Presets 80-89) sets this parameter to “ERL”, or you can manually set this parameter to “ERL” if you want to “start from scratch”.

For best results from the Early Reflections Module room simulation, use only the “wet” outputs of the 606 (set the MIX controls for each channel to “100%”), and do not mix any “dry” signal back in. This is necessary because mixing the “dry” source signal back in with the room simulation signal would interfere with proper signal source and listener placement in the “virtual room”. One way to avoid mixing any “dry” signal back in is to feed the main output(s) of your mixing console to the input(s) of the 606.

NOTE: Since the ERL module creates an omnidirectional sound source in the “virtual room”, you will lose stereo separation between CHANNEL 1 and CHANNEL 2 at the input to the ERL Delay Module

MODULATION

Modulation can be used for a wide variety of effects - basically any time that you want to have a parameter change over a period of time. The modulation can be cyclical in nature, such as when the modulation is controlled by one of the sawtooth wave generators, and it can be random, such as when the modulation is controlled by one of the random generators. The modulation can also be controlled by an external source, such as a midi breath controller. Examples of modulated effects are: stereo auto-panning, flanging and chorusing.

Surprisingly enough, the 606 takes a modular approach to modulation. If you have worked with old modular synthesizers, this approach will seem very familiar. To perform modulation, select a Modulation Module, and then select which oscillator you want to control the Modulation Module. Finally, choose which parameter it is that you want to modulate.

The modulation parameters are: Mod Select, Mod Source, Oscillator Rate, Random 1 Rate, Random 1 Smoothing, Random 2 Rate, Random 2 Smoothing, Log Converter Source, Log Smoothing, Mod Destination, Mod Level for Modulation Modules 1 through 6, and Mod Level Amount for Delay 1 and Delay 2 (MODULATION front panel controls).

The 606 has six Modulation Modules. These modules are not tied to either delay line, but each module can be assigned to many points along the signal path of either delay.

NOTE: Each Modulation Module may be assigned to only one destination at a time.

To activate a Modulation Module, use the MOD SELECT front panel control to select one of the six Modulation Modules. To select Modulation Module 1, adjust the MOD SELECT front panel control until the display reads “nd1”. To select Modulation Module 2, adjust the MOD SELECT front panel control until the display reads “nd2”, and so on. Please note that this is the only front panel control that does not have a corresponding parameter number. The only way to access this control is through the front panel of the 606 or to use Parameters 30 - 35, which perform both the Mod Select and Mod Source selection, as explained in the following paragraph.

Next, use the MOD SOURCE front panel control to select the type of oscillator or controller

Delay F/x Machine 606

606 Delay F/x Machine

that you want to control the modulation. You may also use Parameters 30 - 35 for this. Parameter 30 selects the modulation source for Modulation Module 1, Parameter 31 selects the modulation source for Modulation Module 2, and so on. When you use Parameters 30 - 35, you are both selecting the Modulation Module that you wish to use, and selecting the modulation source.

For smooth, continuous up and down, or left and right, modulation, select a triangle waveform. This waveform is useful for effects such as auto-panning. Set the modulation rate with the OSCILLATOR RATE front panel control. You may also use Parameters 50-53 for this. Parameter 50 selects the oscillator rate for the “tri1/saw1” oscillator, Parameter 51 selects the oscillator rate for the “tri2/saw2” oscillator, Parameter 52 selects the oscillator rate for the “tri3” oscillator, and Parameter 53 selects the oscillator rate for the “tri4” oscillator.

For long “sweeps” with a sharp change in level between the finish of one cycle of the waveform and the beginning of the next, use a sawtooth waveform. This waveform is useful for effects such as flanging. Set the modulation rate with the OSCILLATOR RATE front panel control. You may also use Parameters 50 and 51 for this. Parameter 50 selects the oscillator rate for the “tri1/saw1” oscillator, and Parameter 51 selects the oscillator rate for the “tri2/saw2” oscillator.

NOTE: *Each oscillator can only be assigned one oscillator rate at a time. For example, you cannot assign one rate for “tri1” and another rate for “saw1”.*

A random waveshape jumps all over the place and has no pattern to it, as the name suggests. This waveform is useful for effects such as chorusing. Set the update rate with the OSCILLATOR RATE front panel control. Parameter 54 sets the rate of change for Random Modulator 1 and Parameter 56 sets the rate of change for Random Modulator 2. You may use Parameter 55 to smooth (average) the edges of the envelope generated by Random Modulator 1, and use Parameter 57 to smooth (average) the edges of the envelope generated by Random Modulator 2.

Log modulation is based on the level of the audio signal at the log converter source. As the log converter source signal increases, the output of the log converter increases logarithmically. The OSCILLATOR RATE parameter does not apply to log modulation, so if you access that parameter while using log modulation, the display will read “---”. Select the signal source for the log converter with Parameter 58. You may use Parameter 59 to smooth (average) the edges of the envelope generated by the log converter.

MIDI controllers can also be used to run the Modulation Modules. These are also selected with the MOD SOURCE front panel control, and will appear as:

- “**nod**” Mod Wheel
- “**brh**” Breath Controller
- “**FtL**” Foot Controller
- “**vol**” MIDI Volume
- “**bAL**” MIDI Balance
- “**PAn**” MIDI Pan
- “**KLo**” Keyboard Low (lowest keyboard note currently on)
- “**Khi**” Keyboard High (highest keyboard note currently on)

These MOD SOURCE selections require an external MIDI controller, such as a keyboard or MIDI control sliders, to activate and change the modulated parameter.

The MOD DESTINATION front panel control determines which parameter will be modulated by the currently selected Modulation Module. You may also use Parameters 36 - 41 for this. Parameter 36 determines the parameter to be modulated by Modulation Module 1, Parameter 37 determines the parameter to be modulated by Modulation Module 2, and so on. When you use Parameters 36-41, you are both selecting the Modulation Module that you wish to use, and

selecting the modulation destination.

The MOD LEVEL front panel control determines the amount of modulation that will be applied by the currently selected Modulation Module. You may also use Parameters 42 - 47 for this. Parameter 42 determines the amount of modulation that will be applied by Modulation Module 1, Parameter 43 determines the amount of modulation that will be applied by Modulation Module 2, and so on. The MOD LEVEL control, or Parameters 42 - 47, allow you to set up different modulation levels for each Modulation Module.

The MODULATION front panel control for Delay Line 1 (Parameter 3) adjusts a master level for all Modulation Modules that are assigned to Delay Line 1. The MODULATION front panel control for Delay Line 2 (Parameter 7) adjusts a master level for all Modulation Modules that are assigned to Delay Line 2. These controls are for adjusting overall modulation levels for Delay Lines 1 and 2, as opposed to the MOD LEVEL controls, which adjust the individual Modulation Module output levels. This ability to adjust overall modulation levels allows you to smoothly bring the modulation effects in and out of the delay lines.

6006 Delay F/x Machine

All parameters are accessed by pressing the SELECT button to choose the top command line, and then using the far right knob (in the GLOBAL section) to select the parameter. The most commonly used parameters also have corresponding knobs on the front panel, for speedy adjustments “on the fly”.

PARAMETER 0: DRY/WET MIX - DELAY 1

This parameter corresponds to the Delay 1 MIX knob, so it can be adjusted by this knob, or by accessing Parameter 0 through the GLOBAL section. This parameter controls the ratio of wet (delayed) signal to dry (not delayed) signal that will reach the output of the 606. Setting this parameter to “0 %” causes only the dry signal to appear at the output. Setting this parameter to “100 %” causes only the wet signal to appear at the output. Setting the parameter at any point in between will result in a mix of wet and dry signal to appear at the output of the 606. The balance between wet and dry signal will be determined by the parameter setting (i.e. a setting of 60% will result in an output signal that is comprised of 40% dry signal and 60% wet signal).

PARAMETER 1: DELAY TIME FOR DELAY 1

This parameter corresponds to the Delay 1 TIME knob, so it can be adjusted by this knob, or by accessing Parameter 1 through the GLOBAL section. This parameter adjusts the length of the delay time for Delay 1. For delays less than 1000 ms. (one second), the length of delay is displayed in milliseconds. For delays of one second or more, the display shows the length of delay in seconds. The delay time determined by this parameter setting will be applied to the audio signal passing through Delay 1. For a visual indication of delay time, the RATE LED for DELAY LINE 1 will flash at a rate determined by the setting of the Delay Time for Delay 1 parameter (for example, if the Delay Time is set to 200 ms., then the RATE LED will flash once every 200 ms.). In high resolution mode, the delay time may be adjusted from 0 to 1.3 seconds. In normal resolution mode, the delay time may be adjusted from 0 to 2.6 seconds. Parameter 69 (Memory Width) selects high resolution (24-bit) or normal resolution (16-bit).

PARAMETER 2: FEEDBACK AMOUNT DELAY 1

This parameter corresponds to the Delay 1 FEEDBACK knob, so it can be adjusted by this knob, or by accessing Parameter 2 through the GLOBAL section. This parameter controls the amount of delayed signal that is fed back through the Delay 1 to be delayed again. Two examples of the use of feedback are: creating “echoes” that slowly die out, and creating continuous repeats ad infinitum. The range of adjustment for the FEEDBACK control is from +1 to -1, with 0 being the OFF position. The number from +1 to -1 represents a multiplier that is applied to the signal that is fed back. For example, if the number +.5 is selected, then the first repeat will be at 50% of the signal strength of the original signal, and the second repeat will be at 50% of the first repeat (25% of the original signal), and so on. When +1 is selected, the repeats are at the same signal strength as the original signal (this is the “continuous repeats ad infinitum” referred to above).

When a negative multiplier is used, the original signal is inverted. For example, if the number -.5 is selected, then the first repeat will be inverted and at 50% of the signal strength of the original signal. The second repeat will be inverted and at 50% of the first repeat (25% of the original signal). Since the first repeat was inverted from the original signal, and the second repeat was inverted again, this would put the signal back in phase. The third repeat will be inverted again and at 50% of the second repeat (12.5% of the original signal), and so on. This signal inversion can change the character of the sound, and is particularly noticeable in effects using short delay times, such as flanging.

PARAMETER 3: MODULATION LEVEL AMOUNT DELAY 1

This parameter corresponds to the Delay 1 MODULATION knob, so it can be adjusted by this knob, or by accessing Parameter 3 through the GLOBAL section. This parameter controls the output level of all modulators affecting Delay 1 [there are six modulators available in the 606, and parameters 36 - 41 determine which modulators will affect Delay 1]. This parameter is not to be

confused with Parameters 42-47, which set the output levels of each Modulation Module individually, and which also allow you to selectively invert the outputs of the Modulation Modules. The Modulation Level Amount Delay 1 is continuously adjustable from 0% (bypass) to 100%. Modulation is typically used for flanging, chorusing and some of the more bizarre effects possible.

PARAMETER 4: DRY/WET MIX - DELAY 2

This parameter corresponds to the Delay 2 MIX knob, so it can be adjusted by this knob, or by accessing Parameter 4 through the GLOBAL section. This parameter controls the ratio of wet (delayed) signal to dry (not delayed) signal that will reach the output of the 606. Setting this parameter to “0 %” causes only the dry signal to appear at the output. Setting this parameter to “100 %” causes only the wet signal to appear at the output. Setting the parameter at any point in between will result in a mix of wet and dry signal to appear at the output of the 606. The balance between wet and dry signal will be determined by the parameter setting (i.e. a setting of 60% will result in an output signal that is comprised of 40% dry signal and 60% wet signal).

PARAMETER 5: DELAY TIME FOR DELAY 2

This parameter corresponds to the Delay 2 TIME knob, so it can be adjusted by this knob, or by accessing Parameter 5 through the GLOBAL section. This parameter adjusts the length of the delay time for Delay 2. For delays less than 1000 milliseconds (one second), the length of delay is displayed in milliseconds. For delays of one second or more, the display shows the length of delay in seconds. The delay time determined by this parameter setting will be applied to the audio signal passing through Delay 2. For a visual indication of delay time, the RATE LED for DELAY LINE 2 will flash at a rate determined by the setting of the Delay Time for Delay 2 parameter (for example, if the Delay Time is set to 200 ms., then the RATE LED will flash once every 200 ms.). In high resolution mode, the delay time may be adjusted from 0 to 1.3 seconds. In normal resolution mode, the delay time may be adjusted from 0 to 2.6 seconds. Parameter 69 (Memory Width) selects high resolution (24-bit) or normal resolution (16-bit).

PARAMETER 6: FEEDBACK AMOUNT DELAY 2

This parameter corresponds to the Delay 2 FEEDBACK knob, so it can be adjusted by this knob, or by accessing Parameter 6 through the GLOBAL section. This parameter controls the amount of delayed signal that is fed back through the Delay 2 to be delayed again. Two examples of the use of feedback are: creating “echoes” that slowly die out, and creating continuous repeats ad infinitum. The range of adjustment for the FEEDBACK control is from +1 to -1, with 0 being the OFF position. The number from +1 to -1 represents a multiplier that is applied to the signal that is fed back. For example, if the number +.5 is selected, then the first repeat will be at 50% of the signal strength of the original signal, and the second repeat will be at 50% of the first repeat (25% of the original signal), and so on. When +1 is selected, the repeats are at the same signal strength as the original signal (this is the “continuous repeats ad infinitum” referred to above).

When a negative multiplier is used, the original signal is inverted. For example, if the number -.5 is selected, then the first repeat will be inverted and at 50% of the signal strength of the original signal. The second repeat will be inverted and at 50% of the first repeat (25% of the original signal). Since the first repeat was inverted from the original signal, and the second repeat was inverted again, this would put the signal back in phase. The third repeat will be inverted again and at 50% of the second repeat (12.5% of the original signal), and so on. This signal inversion can change the character of the sound, and is particularly noticeable in effects using short delay times, such as flanging.

PARAMETER 7: MODULATION LEVEL AMOUNT DELAY 2

This parameter corresponds to the Delay 2 MODULATION knob, so it can be adjusted by this knob, or by accessing Parameter 7 through the GLOBAL section. This parameter globally controls the output level of all modulators affecting Delay 2 [there are six modulators available in the 606, and Parameters 36 - 41 determine which modulators will affect Delay 2]. This parameter is not to

Delay F/x Machine 606

be confused with Parameters 42-47, which set the output levels of each Modulation Module individually, and which also allow you to selectively invert the outputs of the Modulation Modules. The Modulation Level Amount Delay 2 is continuously adjustable from 0% (bypass) to 100%. Modulation is typically used for flanging, chorusing and some of your more bizarre effects.

PARAMETER 8: OUTPUT ATTENUATION

This parameter corresponds to the OUTPUT LEVEL knob, so it can be adjusted by this knob, or by accessing Parameter 8 through the GLOBAL section. This parameter provides attenuation of the output levels of both delay lines simultaneously. The output levels of the delay lines can be adjusted from “0.0” (0dB, unity) on down to “inF” (infinite attenuation, corresponds to “off”).

PARAMETER 9: CHANNEL 1 DRY INPUT PANNED TO OUTPUT BUS

This parameter allows you to route the dry signal from Input 1 to Output 1, Output 2, or both outputs (in whatever proportion that you desire). If you are mixing in stereo, with Output 1 as your left output and Output 2 as your right output (or vice-versa), this would allow you to aurally place the dry signal from Input 1 so that the sound appears to be coming from the left speaker, from the right speaker, or anywhere in between. To route the dry signal from Input 1 to Output 1, select “CH1”. To route the dry signal from Input 1 to Output 2, select “CH2”. To route the dry signal from Input 1 equally to Output 1 and Output 2, select “0”. Please note that the values between “CH1” and “0” are displayed on the left portion of the display, to indicate that more of the dry input is being routed to Output 1 than to Output 2, and the values between “0” and “CH2” are displayed in the right portion of the display, to indicate that more of the dry input is being routed to Output 2 than to Output 1. This is a constant power control, which means that, as you pan from CH1 to CH2, the apparent output level remains the same.

PARAMETER 10: CHANNEL 2 DRY INPUT PANNED TO OUTPUT BUS

This parameter allows you to route the dry signal from Input 2 to Output 1, Output 2, or both outputs (in whatever proportion that you desire). If you are mixing in stereo, with Output 1 as your left output and Output 2 as your right output (or vice-versa), this would allow you to aurally place the dry signal from Input 2 so that the sound appears to be coming from the left speaker, from the right speaker, or anywhere in between. To route the dry signal from Input 2 to Output 1, select “CH1”. To route the dry signal from Input 2 to Output 2, select “CH2”. To route the dry signal from Input 2 equally to Output 1 and Output 2, select “0”. Please note that the values between “CH1” and “0” are displayed on the left portion of the display, to indicate that more of the dry input is being routed to Output 1 than to Output 2, and the values between “0” and “CH2” are displayed in the right portion of the display, to indicate that more of the dry input is being routed to Output 2 than to Output 1. This is a constant power control, which means that, as you pan from CH1 to CH2, the apparent output level remains the same.

PARAMETER 11: DELAY 1 SOURCE

This parameter selects which input, or combination of inputs, will feed the Delay 1 line. This parameter may be adjusted to select Input 1, Input 2 or both inputs (in whatever proportion that you desire). To select Input 1 as the Delay 1 source, adjust until the display reads “CH1”. To select Input 2 as the Delay 1 source, adjust until the display reads “CH2”. To select both inputs equally, adjust until the display reads “0”. Please note that the values between “CH1” and “0” are displayed on the left portion of the display, to indicate that Input 1 comprises a larger percentage of the input to Delay 1 than Input 2, and the values between “0” and “CH2” are displayed in the right portion of the display, to indicate that Input 2 comprises a larger percentage of the input to Delay 1 than Input 1.

PARAMETER 12: DELAY 1 FEEDBACK SOURCE MIX

This parameter selects which delay line, or combination of both delay lines, will be the Delay 1 feedback source. This parameter may be adjusted to select Delay 1, Delay 2 or both delay lines (in

whatever proportion you desire). To select Delay 1 as the source, adjust until the display reads “dL1”. To select Delay 2 as the source, adjust until the display reads “dL2”. To select both delay lines equally, adjust until the display reads “0”. Please note that the values between “dL1” and “0” are displayed on the left portion of the display, to indicate that Delay 1 comprises a larger percentage of the input to Delay 1 feedback than Delay 2, and the values between “0” and “dL2” are displayed in the right portion of the display, to indicate that Delay 2 comprises a larger percentage of the input to Delay 1 feedback than Delay 1. This is a constant power control, which means that, as you pan from dL1 to dL2, the apparent source level remains the same.

PARAMETER 13: DELAY 1 FILTER TYPE

This parameter selects the type of filter, in the Filter Module, to be applied to Delay 1. The choices are: low-pass single-pole (LP1), low-pass 2-pole (LP2), low-pass 2-pole resonant (L2R), band-pass (BP), band-pass resonant (BPR), notch (NCH), high-pass single-pole (HP1) and high-pass 2-pole (HP2). Please note that all filters except LP1 and HP1 are resonant, however the filters that are marked with an “R” (L2R and BPR) will not reduce the input level when resonance is increased. This causes the L2R and BPR filters to have a tendency to “ring”, which can be desirable for special effects, such as flanging. All of the other filters, which are not marked with an “R”, will reduce the input level when resonance is increased, to reduce the possibility of overload. Note that there is no “Off” position to bypass the Filter Module. This is because Parameters 16 and 17 select the Delay 1 Feedback Source and Delay 1 Wet Signal Source respectively. The source selections for Parameters 16 and 17 are: “dir” (direct, which bypasses the Filter Module), “FLt” (the output of the Filter Module) and “diF” (the output of the Diffusion Module, which is fed from the Filter Module). You can bypass the Filter module by selecting “dir” for Parameters 16 and 17.

PARAMETER 14: DELAY 1 FILTER FREQUENCY

This parameter corresponds to the Delay 1 FILTER FREQ. knob (middle command line), so it can be adjusted by this knob, or by accessing Parameter 14 through the GLOBAL section. This parameter selects the frequency of the filter selected by Parameter 13. The filter frequency is incrementally adjustable from 46 Hz to 21 kHz for 1st-order filters (LP1 and HP1), and from 16 Hz to 7.45 kHz for state-variable filters (LP2, L2R, BP, BPR, NCH, and HP2). The filter frequency selected is the frequency at the cutoff frequency (3 dB-down point) for the low-pass and high-pass filters, and it is the center frequency for the notch and band-pass filters.

PARAMETER 15: DELAY 1 FILTER Q

This parameter corresponds to the Delay 1 FILTER Q knob (middle command line), so it can be adjusted by this knob, or by accessing Parameter 15 through the GLOBAL section. This parameter selects the filter Q, which is inversely proportional to the bandwidth of the filter ($Q=f_0/B$, where f_0 =center frequency and B =bandwidth). The Q is incrementally variable from .70 (optimum damping factor for low-pass filters, very wide bandwidth) to 107 (very narrow bandwidth). Please note that the Q is fixed at .70 for single-pole filters. Therefore, the 606 does not allow an adjustment for Q when using filters LP1 or HP1.

PARAMETER 16: DELAY 1 FEEDBACK SIGNAL SOURCE SELECT

This parameter determines whether the feedback signal is derived from the output of the Delay Module only (dir), from the output of the Filter Module (FLt), or from the output of the Diffusion Module (diF). The Diffusion Module follows the Filter Module, and the Filter Module follows the Delay Module. When you select the output of the Delay Module, the selected signal passes through the Delay Module, but not the Filter Module or Diffusion Module. When you select the output of the Filter Module, the selected signal passes through the Delay Module and Filter Module, but not the Diffusion Module. When you select the Diffusion Module, the signal passes through all three modules. This is your opportunity to bypass the Filter Module, or the combination of the Filter Module and the Diffusion Module, if you so desire.

Delay F/x
Machine

606

PARAMETER 17: DELAY 1 WET SIGNAL

This parameter selects the source for the Delay 1 wet (delayed) signal that will be routed to the output of Delay 1. The choices are: the output of the Delay Module only (dir), the output of the Filter Module (Flt), or the output of the Diffusion Module (diF). The Diffusion Module follows the Filter Module, and the Filter Module follows the Delay Module. When you select the output of the Delay Module, the selected signal passes through the Delay Module, but not the Filter Module or Diffusion Module. When you select the output of the Filter Module, the selected signal passes through the Delay Module and Filter Module, but not the Diffusion Module. When you select the Diffusion Module, the signal passes through all three modules. This is your opportunity to bypass the Filter Module, or the combination of the Filter Module and the Diffusion Module, if you so desire.

PARAMETER 18: DELAY 1 WET PAN

This parameter determines whether the Delay 1 wet (delayed) signal is routed to Output 1, Output 2, or both outputs (in whatever proportion you desire). If you are mixing in stereo, with Output 1 as your left output and Output 2 as your right output (or vice-versa), this would allow you to aurally place the wet signal from Delay 1 so that the sound appears to be coming from the left speaker, from the right speaker, or anywhere in between. To route the wet signal from Delay 1 to Output 1, select “CH1”. To route the wet signal from Delay 1 to Output 2, select “CH2”. To route the wet signal from Delay 1 equally to Output 1 and Output 2, select “0”. Please note that the values between “CH1” and “0” are displayed on the left portion of the display, to indicate that more of the Delay 1 wet signal is being routed to Output 1 than to Output 2, and the values between “0” and “CH2” are displayed in the right portion of the display, to indicate that more of the Delay 1 wet signal is being routed to Output 2 than to Output 1.

This is a constant power control, which means that, as you pan from CH1 to CH2, the apparent output level remains the same.

PARAMETER 19: DELAY 1 WET ATTENUATION

This parameter controls the output level of the Delay 1 wet signal. This attenuation occurs just before the signal is routed to one or both channel outputs. The amount of attenuation can be adjusted from “0.0” (unity, no attenuation) to “inF” (infinite attenuation). Infinite attenuation corresponds to “off”.

PARAMETER 20: DELAY 2 INPUT SOURCE

This parameter selects which combination of inputs will feed the Delay 2 Input Mixture Module. This parameter may be adjusted to select either Channel 1 Input and Channel 2 Input (select “In” on the display) or Delay 1 Input and Delay 1 Wet Signal (select “dL1” on the display) as the sources that are fed to the input of the Delay 2 Input Mixture Module. Parameter 21 allows you to further narrow down your Delay 2 input selection.

PARAMETER 21: DELAY 2 INPUT MIXTURE

This parameter determines which input or combination of inputs, that were selected by Parameter 20, will feed the Delay 2 line.

If Channel 1 Input and Channel 2 Input were selected in Parameter 20, then Parameter 21 will allow you to choose either Channel 1 Input, Channel 2 Input, or a combination of both inputs (in whatever proportion you desire). In this instance, to select Channel 1 Input as the Delay 2 source, adjust until the display reads “CH1”. To select Channel 2 Input as the Delay 2 source, adjust until the display reads “CH2”. To select both channel inputs equally, adjust until the display reads “0”. Please note that the values between “CH1” and “0” are displayed on the left portion of the display, to indicate that Channel 1 Input comprises a larger percentage of the input to Delay 2 than Channel 2 Input, and the values between “0” and “CH2” are displayed in the right portion of the display, to indicate that Channel 2 Input comprises a larger percentage of the input to Delay 2 than Channel 1 Input.

If Delay 1 Input and Delay 1 Wet Signal were selected in Parameter 20, then Parameter 21 will allow you to choose either Delay 1 Input, Delay 1 Wet Signal, or a combination of the two (in whatever proportion you desire). In this instance, to select Delay 1 Input as the Delay 2 source, adjust until the display reads “In”. When Delay 1 Input is selected, the input mix chosen by Parameter 11 will feed both Delay 1 and Delay 2. To select Delay 1 Wet Signal as the Delay 2 source, adjust until the display reads “dL1”.

To select both Delay 1 Input and Delay 1 Wet Signal equally, adjust until the display reads “0”. Please note that the values between “In” and “0” are displayed on the left portion of the display, to indicate that Delay 1 Input comprises a larger percentage of the input to Delay 2 than Delay 1 Wet Signal, and the values between “0” and “dL1” are displayed in the right portion of the display, to indicate that Delay 1 Wet Signal comprises a larger percentage of the input to Delay 2 than Delay 1 Input.

PARAMETER 22: DELAY 2 FEEDBACK SOURCE

This parameter selects which delay line, or combination of both delay lines, will be the Delay 2 feedback source. This parameter may be adjusted to select Delay 1, Delay 2 or both delay lines (in whatever proportion you desire). To select Delay 1 as the source, adjust until the display reads “dL1”. To select Delay 2 as the source, adjust until the display reads “dL2”. To select both delay lines equally, adjust until the display reads “0”. Please note that the values between “dL1” and “0” are displayed on the left portion of the display, to indicate that Delay 1 comprises a larger percentage of the input to Delay 2 feedback than Delay 2, and the values between “0” and “dL2” are displayed in the right portion of the display, to indicate that Delay 2 comprises a larger percentage of the input to Delay 2 feedback than Delay 1. This is a constant power control, which means that, as you pan from dL1 to dL2, the apparent source level remains the same.

PARAMETER 23: DELAY 2 FILTER TYPE

This parameter selects the type of filter, in the Filter Module, to be applied to Delay 2. The choices are: low-pass single-pole (LP1), low-pass 2-pole (LP2), low-pass 2-pole resonant (L2R), band-pass (BP), band-pass resonant (BPR), notch (NCH), high-pass single-pole (HP1) and high-pass 2-pole (HP2). Please note that all filters except LP1 and HP1 are resonant, however the filters that are marked with an “R” (L2R and BPR) will not reduce the input level when resonance is increased. This causes the L2R and BPR filters to have a tendency to “ring”, which can be desirable for special effects, such as flanging. All of the other filters, which are not marked with an “R”, will reduce the input level when resonance is increased, to minimize “ringing”. Note that there is no “Off” position to bypass the Filter Module. This is because Parameters 26 and 27 select the Delay 1 Feedback Source and Delay 1 Wet Signal Source respectively. The source selections for Parameters 26 and 27 are: “dir” (direct, which bypasses the Filter Module), “FLt” (the output of the Filter Module) and “diF” (the output of the Diffusion Module, which is fed from the Filter Module). You can bypass the Filter module by selecting “dir” for Parameters 26 and 27.

PARAMETER 24: DELAY 2 FILTER FREQUENCY

This parameter corresponds to the Delay 2 FILTER FREQ. knob (middle command line), so it can be adjusted by this knob, or by accessing Parameter 24 through the GLOBAL section. This parameter selects the frequency of the filter selected by Parameter 23. The filter frequency is incrementally adjustable from 46 Hz to 21 kHz for 1st-order filters (LP1 and HP1), and from 16 Hz to 7.45 kHz for state-variable filters (LP2, L2R, BP, BPR, NCH, and HP2). The filter frequency selected is the frequency at the cutoff frequency (3 dB-down point) for the low-pass and high-pass filters, and it is the center frequency for the notch and band-pass filters.

PARAMETER 25: DELAY 2 FILTER BANDWIDTH

This parameter corresponds to the Delay 2 FILTER Q knob (middle command line), so it can be adjusted by this knob, or by accessing Parameter 25 through the GLOBAL section. This parameter selects the filter Q, which is inversely proportional to the bandwidth of the filter ($Q=f_0/B$, where f_0 =center frequency and B =bandwidth). The Q is incrementally variable from .70 (optimum

Delay F/x Machine 6006

damping factor for low-pass filters, very wide bandwidth) to 107 (very narrow bandwidth). Please note that the Q is fixed at .70 for single-pole filters. Therefore, the 606 does not allow an adjustment for Q when using filters LP1 or HP1.

PARAMETER 26: DELAY 2 FEEDBACK SIGNAL SOURCE

This parameter determines whether the feedback signal is derived from the output of the Delay Module only (dir), from the output of the Filter Module (FLt), or from the output of the Diffusion Module (diF). The Diffusion Module follows the Filter Module, and the Filter Module follows the Delay Module. When you select the output of the Delay Module, the selected signal passes through the Delay Module, but not the Filter Module or Diffusion Module. When you select the output of the Filter Module, the selected signal passes through the Delay Module and Filter Module, but not the Diffusion Module. When you select the Diffusion Module, the signal passes through all three modules. This is your opportunity to bypass the Filter Module, or the combination of the Filter Module and the Diffusion Module, if you so desire.

PARAMETER 27: DELAY 2 WET SIGNAL

This parameter selects the source for the Delay 2 wet (delayed) signal that will be routed to the output of Delay 2. The choices are: the output of the Delay Module only (dir), the output of the Filter Module (FLt), or the output of the Diffusion Module (diF). The Diffusion Module follows the Filter Module, and the Filter Module follows the Delay Module. When you select the output of the Delay Module, the selected signal passes through the Delay Module, but not the Filter Module or Diffusion Module. When you select the output of the Filter Module, the selected signal passes through the Delay Module and Filter Module, but not the Diffusion Module. When you select the Diffusion Module, the signal passes through all three modules. This is your opportunity to bypass the Filter Module, or the combination of the Filter Module and the Diffusion Module, if you so desire.

PARAMETER 28: DELAY 2 WET PAN

This parameter determines whether the Delay 2 wet (delayed) signal is routed to Output 1, Output 2, or both outputs (in whatever proportion you desire). If you are mixing in stereo, with Output 1 as your left output and Output 2 as your right output (or vice-versa), this would allow you to aurally place the wet signal from Delay 2 so that the sound appears to be coming from the left speaker, from the right speaker, or anywhere in between. To route the wet signal from Delay 2 to Output 1, select “CH1”. To route the wet signal from Delay 2 to Output 2, select “CH2”. To route the wet signal from Delay 2 equally to Output 1 and Output 2, select “0”. Please note that the values between “CH1” and “0” are displayed on the left portion of the display, to indicate that more of the Delay 2 wet signal is being routed to Output 1 than to Output 2, and the values between “0” and “CH2” are displayed in the right portion of the display, to indicate that more of the Delay 2 wet signal is being routed to Output 2 than to Output 1.

This is a constant power control, which means that, as you pan from CH1 to CH2, the apparent output level remains the same.

PARAMETER 29: DELAY 2 WET ATTENUATION

This parameter controls the output level of the Delay 2 wet signal. This attenuation occurs just before the signal is routed to one or both channel outputs. The amount of attenuation can be adjusted from “0.0” (unity, no attenuation) to “inF” (infinite attenuation). Infinite attenuation corresponds to “off”.

PARAMETERS 30 - 35: MODULATION SOURCE FOR MODULATION MODULES 1 - 6

These parameters correspond to the MOD SOURCE knob (top command line), so they can be adjusted by this knob, or by accessing Parameters 30-35 through the GLOBAL section. These parameters select the modulation source for Modulation Modules 1 through 6. Modulation is used to shape the envelope of the signal that is assigned to a Modulation Module. The Modulation Module performs the modulation, but in order to modulate a signal, the Modulation Module that

you wish to use must be connected to a Modulation Source. The Modulation Source determines the type of modulation (wave shape) that will be applied to the signal assigned to the Modulation Module. Parameter 30 selects the modulation source for Modulation Module 1, Parameter 31 selects the modulation source for Modulation Module 2, and so on. If you are using the MOD SOURCE knob to make your adjustments, rather than accessing Parameters 30-35, then you will need to first select which module you want to work on with the MOD SELECT knob (module 1 corresponds to “nd1” on the display, module 2 corresponds to “nd2” on the display, and so on), and then set the modulation source for the module that you just selected, using the MOD SOURCE knob.

The 606 has seven internal modulation sources and eight options for midi modulation control. The seven internal modulation sources are:

- Generator 1** Generates either a triangle wave or a sawtooth wave. For a triangle wave, select “Tr1” (looks like “7r1” on the display). For a sawtooth wave, select “SA1”.
- Generator 2** Generates either a triangle wave or a sawtooth wave. For a triangle wave, select “Tr2” (looks like “7r2” on the display). For a sawtooth wave, select “SA2”.
- Generator 3** Generates a triangle wave. Select “Tr3” (looks like “7r3” on the display).
- Generator 4** Generates a triangle wave. Select “Tr4” (looks like “7r4” on the display).
- Random Generator 1** Generates random values. Select “rn1”.
- Random Generator 2** Generates random values. Select “rn2”.
- Log Converter** Generates a wave shape that is derived from the level of the audio signal that is selected with Parameter 58. Select “LoG”.

The eight options for modulation control via midi are:

- Modulation Wheel** The wave shape is controlled by an external modulation wheel. The midi control change number is “1”. Select “nod”.
- Breath Controller** The wave shape is controlled by an external breath controller. The midi control change number is “2”. Select “brh”.
- Foot Controller** The wave shape is controlled by an external foot controller. The midi control change number is “4”. Select “FtC”.
- Midi Volume** The wave shape is modulated by the midi volume control. The midi control change number is “7”. Select “voL”.
- Midi Balance** The wave shape is modulated by the midi balance control. The midi control change number is “8”. Select “bAL”.
- Midi Pan** The wave shape is modulated by the midi pan control. The midi control change number is “10”. Select “PAn”.
- High Midi Note** The wave shape is modulated by the highest note currently being played by the controlling midi device. If just one note is being played, then that qualifies as the highest note. Select “KHi” (due to the limitations of 7-segment displays, the “K” resembles a backwards “y”).
- Low Midi Note** The wave shape is modulated by the lowest note currently being played by the controlling midi device. If just one note is being played, then that qualifies as the lowest note. Select “KLo” (due to the limitations of 7-segment displays, the “K” resembles a backwards “y”).

Delay F/x Machine 606

PARAMETERS 36 - 41: MODULATION DESTINATION FOR MODULATORS 1 - 6

These parameters correspond to the MOD DESTINATION knob (top command line), so it can be adjusted by this knob, or by accessing Parameters 36-41 through the GLOBAL section. These parameters determine where the outputs of Modulation Modules 1 through 6 will be routed. In other words, these parameters determine which parameters the Modulation Modules will control. Parameter 36 selects the modulation destination for the output of Modulation Module 1, Parameter 37 selects the modulation destination for the output of Modulation Module 2, and so on. If you are using the MOD DESTINATION knob to make your adjustments, rather than accessing Parameters 36-41, then you will need to first select which module you want to work on with the MOD SELECT knob (module 1 corresponds to “nd1” on the display, module 2 corresponds to “nd2” on the display, and so on), and then set the modulation destination for the output of the module that you just selected, using the MOD DESTINATION knob.

The 606 has eighteen possible modulation destinations. The choices are:

- Off** No modulation is used.
- dL1** The Delay Line 1 TIME function will be modulated. This means that the length of delay will increase and decrease as a function of the modulation being applied.
- F1F** The Delay Line 1 FILTER FREQ. function will be modulated. This means that the cutoff frequency (for low-pass and high-pass filters) or the center frequency (for notch and band-pass filters), depending on the filter type that you selected with Parameter 13, will increase and decrease in frequency as a function of the modulation being applied.
- di1** The Delay Line 1 MIX function will be modulated. This means that the balance between wet and dry (delayed and non-delayed) signal will change as a function of the modulation being applied.
- Fb1** The Delay Line 1 Feedback Source Mix function will be modulated. This means that the balance between Delay 1 Feedback Signal and Delay 2 Feedback Signal being fed to the input of Delay Line 1 will change as a function of the modulation being applied.
- 1n1** The Delay 1 Input Dry Output Pan will be modulated. This means that the dry (undelayed) signal from Delay 1 Input, at a level determined by the setting of Parameter 0, will be panned back and forth between CHANNEL 1 OUTPUT and CHANNEL 2 OUTPUT, as a function of the modulation being applied.
- 1L1** The Delay 1 Input Dry Output Pan Attenuation will be modulated. This means that the level of the dry (undelayed) signal from Delay 1 Input, as measured at the Input 1 Dry Output Pan (right before the dry signal is routed to one or both outputs), will increase and decrease as a function of the modulation being applied.
- do1** The Delay Line 1 Wet Output Pan will be modulated. This means that the wet (delayed) signal from Delay Line 1, at a level determined by the setting of Parameter 0, will be panned back and forth between CHANNEL 1 OUTPUT and CHANNEL 2 OUTPUT, as a function of the modulation being applied.
- dA1** The Delay Line 1 Wet Output Pan Attenuation will be modulated. This means that the level of the wet (delayed) signal from Delay Line 1, as measured at the Input 1 Wet Output Pan (right before the dry signal is routed to one or both outputs), will increase and decrease as a function of the modulation being applied.
- dL2** The Delay Line 2 TIME function will be modulated. This means that the length of delay will increase and decrease as a function of the modulation being applied.
- F2F** The Delay Line 2 FILTER FREQ. function will be modulated. This means that the cutoff frequency (for low-pass and high-pass filters) or the center frequency (for notch and band-pass filters), depending on the filter type that you selected with

Parameter 23, will increase and decrease in frequency as a function of the modulation being applied.

- di2** The Delay Line 2 MIX function will be modulated. This means that the balance between wet and dry (delayed and non-delayed) signal will change as a function of the modulation being applied.
- Fb2** The Delay Line 2 Feedback Source Mix function will be modulated. This means that the balance between Delay 1 Feedback Signal and Delay 2 Feedback Signal being fed to the input of Delay Line 2 will change as a function of the modulation being applied.
- 1n2** The Delay 2 Input Dry Output Pan will be modulated. This means that the dry (undelayed) signal from Delay 2 Input, at a level determined by the setting of Parameter 4, will be panned back and forth between CHANNEL 1 OUTPUT and CHANNEL 2 OUTPUT, as a function of the modulation being applied.
- 1L2** The Delay 2 Input Dry Output Pan Attenuation will be modulated. This means that the level of the dry (undelayed) signal from Delay 2 Input, as measured at the Input 2 Dry Output Pan (right before the dry signal is routed to one or both outputs), will increase and decrease as a function of the modulation being applied.
- do2** The Delay Line 2 Wet Output Pan will be modulated. This means that the wet (delayed) signal from Delay Line 2, at a level determined by the setting of Parameter 4, will be panned back and forth between CHANNEL 1 OUTPUT and CHANNEL 2 OUTPUT, as a function of the modulation being applied.
- dA2** The Delay Line 2 Wet Output Pan Attenuation will be modulated. This means that the level of the wet (delayed) signal from Delay Line 2, as measured at the Input 2 Wet Output Pan (right before the dry signal is routed to one or both outputs), will increase and decrease as a function of the modulation being applied.
- OtL** The Stereo Output Level (Parameter 8) will be modulated. This means that the output level of both channels will rise and fall together, as a function of the modulation being applied. This will happen even if you are in DUAL MONO mode.

PARAMETERS 42 - 47: MODULATION LEVEL FOR MODULATION MODULES 1 - 6

These parameters correspond to the MOD LEVEL knob (top command line), so they can be adjusted by this knob, or by accessing Parameters 42-47 through the GLOBAL section. These parameters determine the output levels of the individual Modulation Modules. These parameters are not to be confused with Parameters 3 and 7, which globally control the output levels of all modulators assigned to Delay Line 1 and Delay Line 2, respectively. Parameters 42-47 allow you to set the Modulation Modules up at different output levels, relative to each other. Parameters 3 and 7 then maintain these output relationships between the individual Modulation Modules when Parameters 3 and 7 globally change the output level of all Modulation Modules assigned to Delay Line 1 or Delay Line 2. Parameters 42-47 also give you the opportunity to invert the signal at the output of any Modulation Module. Parameters 3 and 7 do not give you the opportunity to invert the signal. Parameter 42 selects the output level of Modulation Module 1, Parameter 43 selects the output level of Modulation Module 2, and so on. If you are using the MOD LEVEL knob to make your adjustments, rather than accessing Parameters 42-47, then you will need to first select which module you want to work on with the MOD SELECT knob (module 1 corresponds to “nd1” on the display, module 2 corresponds to “nd2” on the display, and so on), and then set the output level of the module that you just selected, using the MOD SELECT knob. Parameters 42-47 are continuously variable from “-1 to +1”. The “0” position corresponds to “OFF”. The “1” position (either + or -) corresponds to the maximum output level, which is unity gain.

When a negative multiplier is used, the signal from the Modulation Module is inverted. This will invert the envelope that is being generated by the Modulation Module. When you use sawtooth, triangle or log waveforms as the Modulation Module source, this signal inversion greatly increases

Delay F/x
Machine

606

your envelope options for changing the character of the sound at the final output of the 606, especially when both the inverted and non-inverted outputs of the same oscillator are used to modulate multiple destinations.

PARAMETER 48: DELAY 1 DIFFUSION AMOUNT

This parameter corresponds to the Delay Line 1 DIFFUSION AMOUNT knob (middle command line), so it can be adjusted by this knob, or by accessing Parameter 48 through the GLOBAL section. This parameter is used to simulate natural reverberation. As sound is randomly reflected off the hard surfaces in an enclosed space, a reverb “tail”, or “blurring” of the discrete echoes, builds up, especially in highly reflective environments. This “blurring” of the sound happens because the individual frequencies that comprise the source audio are reflected and absorbed at different rates. Diffusion simulates this by delaying the component frequencies at different rates, in a manner consistent with natural reverb. This parameter is variable from “OFF” (0) to “16” (maximum diffusion).

PARAMETER 49: DELAY 2 DIFFUSION AMOUNT

This parameter corresponds to the Delay Line 2 DIFFUSION AMOUNT knob (middle command line), so it can be adjusted by this knob, or by accessing Parameter 49 through the GLOBAL section. This parameter is used to simulate natural reverberation. As sound is randomly reflected off the hard surfaces in an enclosed space, a reverb “tail”, or “blurring” of the discrete echoes, builds up, especially in highly reflective environments. This “blurring” of the sound happens because the individual frequencies that comprise the source audio are reflected and absorbed at different rates. Diffusion simulates this by delaying the component frequencies at different rates, in a manner consistent with natural reverb. This parameter is variable from “OFF” (0) to “16” (maximum diffusion).

PARAMETER 50 - 53: OSCILLATOR FREQUENCY

These parameters correspond to the OSCILLATOR RATE knob (top command line), so they can be adjusted by this knob, or by accessing Parameters 50-53 through the GLOBAL section. These parameters control the rate of oscillation (frequency) of the signals generated by the “tri1/saw1, tri2/saw2, tri3” and “tri4” oscillators. This determines what the modulation rate will be when one of these oscillators is assigned to a Modulation Module. Parameter 50 sets the oscillation rate of the “tri1/saw1” oscillator, Parameter 51 sets the oscillation rate of the “tri2/saw2” oscillator, and so on. If you are using the OSCILLATOR RATE knob to make your adjustments, rather than accessing Parameters 50-53, then you will need to first select which oscillator you want to work on with the MOD SOURCE knob (top command line) and then set the oscillator rate of the oscillator that you just selected, using the OSCILLATOR RATE knob. These parameters are adjustable from .031 to 48.9 Hz.

PARAMETER 54: RANDOM 1 RATE

This parameter sets the rate of change for the oscillator that generates Mod Source “ran1”. This determines the modulation rate of change when this oscillator is assigned to a Modulation Module. This rate is adjustable from .031 to 48.9 Hz.

PARAMETER 55: RANDOM 1 SMOOTHING

This parameter smooths out the envelope generated by the “ran1” oscillator. It does this by averaging the changes generated by the “ran1” oscillator. This parameter adjusts a time constant from 10 milliseconds to 1.8 seconds.

PARAMETER 56: RANDOM 2 RATE

This parameter sets the rate of change for the oscillator that generates Mod Source “ran2”. This determines the modulation rate of change when this oscillator is assigned to a Modulation Module. This rate is adjustable from .031 to 48.9 Hz.

PARAMETER 57: RANDOM 2 SMOOTHING

This parameter smooths out the envelope generated by the “ran1” oscillator. It does this by averaging the changes generated by the “ran1” oscillator. This parameter adjusts a time constant from 10 milliseconds to 1.8 seconds.

PARAMETER 58: LOG CONVERTER SOURCE

This parameter determines which source will be fed to the log converter. The choices are:

- In1** The signal connected to Input 1 will be fed to the log converter.
- In2** The signal connected to Input 2 will be fed to the log converter.
- dL1** The signal at the output of Delay Line 1 is fed to the log converter.
- dL2** The signal at the output of Delay Line 2 is fed to the log converter.
- Ot1** The signal at the Channel 1 Output is fed to the log converter.
- Ot2** The signal at the Channel 2 Output is fed to the log converter.

PARAMETER 59: LOG SMOOTHING

This parameter smooths out the envelope generated by the log converter. It does this by averaging the changes generated by the log converter. This parameter adjusts a time constant from 10 milliseconds to 1.8 seconds.

PARAMETER 60: ROOM SIZE

This is an EARLY REFLECTIONS MODULE (room simulation program) parameter. This parameter corresponds to the ROOM SIZE knob (top command line), so it can be adjusted by this knob, or by accessing Parameter 60 through the GLOBAL section. This parameter determines the size of the room to be simulated for early reflection programs. The early reflections programs simulate the aural placement cues provided by the acoustic reflections that you would hear if you were standing in a room of the selected size. Please note that Parameter 69 must be set to “ErL” before Parameter 60 may be used. The choices for Parameter 60 are:

- Sn1** Small room early reflection simulation number 1. This option simulates a room that is 5.9 meters (length) by 6.7 meters (width) by 4.7 meters (height), or 19.4 feet (length) by 22 feet (width) by 15.4 feet (height).
- Sn2** Small room early reflection simulation number 2. This option simulates a room that is 6.7 meters (length) by 7.9 meters (width) by 4.7 meters (height), or 22 feet (length) by 25.9 feet (width) by 15.4 feet (height).
- Sn3** Small room early reflection simulation number 3. This option simulates a room that is 6.7 meters (length) by 7.9 meters (width) by 5.9 meters (height), or 22 feet (length) by 25.9 feet (width) by 19.4 feet (height).
- Sn4** Small room early reflection simulation number 4. This option simulates a room that is 7.9 meters (length) by 8.9 meters (width) by 5.9 meters (height), or 25.9 feet (length) by 29.2 feet (width) by 19.4 feet (height).
- NE1** Medium room early reflection simulation number 1. This option simulates a room that is 8.9 meters (length) by 7.9 meters (width) by 5.9 meters (height), or 29.2 feet (length) by 25.9 feet (width) by 19.4 feet (height).
- NE2** Medium room early reflection simulation number 2. This option simulates a room that is 10.1 meters (length) by 8.9 meters (width) by 5.9 meters (height), or 33.1 feet (length) by 29.2 feet (width) by 25.9 feet (height).
- NE3** Medium room early reflection simulation number 3. This option simulates a room that is 11.3 meters (length) by 10.1 meters (width) by 8.9 meters (height), or 37.1 feet (length) by 33.1 feet (width) by 29.2 feet (height).

-
- NE4** Medium room early reflection simulation number 4. This option simulates a room that is 13.1 meters (length) by 11.3 meters (width) by 10.1 meters (height), or 43 feet (length) by 37.1 feet (width) by 33.1 feet (height).
 - LG1** Large room early reflection simulation number 1. This option simulates a room that is 14.9 meters (length) by 13.1 meters (width) by 11.3 meters (height), or 49 feet (length) by 43 feet (width) by 37.1 feet (height).
 - LG2** Large room early reflection simulation number 2. This option simulates a room that is 15.7 meters (length) by 14.9 meters (width) by 13.1 meters (height), or 51.5 feet (length) by 49 feet (width) by 43 feet (height).
 - LG3** Large room early reflection simulation number 3. This option simulates a room that is 16.7 meters (length) by 14.9 meters (width) by 15.7 meters (height), or 54.8 feet (length) by 49 feet (width) by 51.5 feet (height).
 - LG4** Large room early reflection simulation number 4. This option simulates a room that is 17.9 meters (length) by 14.9 meters (width) by 16.7 meters (height), or 58.7 feet (length) by 49 feet (width) by 54.8 feet (height).
 - HL1** Hall early reflection simulation number 1. This option simulates a room that is 19.1 meters (length) by 14.9 meters (width) by 17.9 meters (height), or 62.7 feet (length) by 49 feet (width) by 58.7 feet (height).
 - HL2** Hall early reflection simulation number 2. This option simulates a room that is 21.1 meters (length) by 14.9 meters (width) by 17.9 meters (height), or 69.2 feet (length) by 49 feet (width) by 58.7 feet (height).
 - HL3** Hall early reflection simulation number 3. This option simulates a room that is 33.1 meters (length) by 14.9 meters (width) by 17.9 meters (height), or 108.6 feet (length) by 49 feet (width) by 58.7 feet (height).
 - HL4** Hall early reflection simulation number 4. This option simulates a room that is 37.3 meters (length) by 14.9 meters (width) by 17.9 meters (height), or 122.4 feet (length) by 49 feet (width) by 58.7 feet (height).

PARAMETER 61: EARLY REFLECTION TAP ATTENUATION

This is an EARLY REFLECTIONS MODULE (room simulation program) parameter. This parameter controls the output attenuation of the Early Reflections Module signal. This parameter is adjustable from “inF” (infinite attenuation, corresponds to “OFF”) to “0” (zero attenuation, unity gain).

PARAMETER 62: SIGNAL SOURCE L/R

This is an EARLY REFLECTIONS MODULE (room simulation program) parameter. This parameter is calculated from the sound reflections that would occur in a “virtual room”. This parameter allows you to aurally place an omnidirectional signal source so that the sound appears to be coming from the far left in the room, from the far right, or somewhere in between. To aurally place the signal source to the far left in the room, select “L”. To aurally place the signal source to the far right in the room, select “r”. To aurally place the signal source so that it is on centered between left and right in the room, select “0”. Please note that the values between “L” and “0” are displayed on the left portion of the display, to indicate that the signal source is aurally placed to the left of center in the room, and the values between “0” and “r” are displayed in the right portion of the display, to indicate that the signal source is aurally placed to the right of center in the room.

PARAMETER 63: SIGNAL SOURCE F/R

This is an EARLY REFLECTIONS MODULE (room simulation program) parameter. This parameter is calculated from the sound reflections that would occur in a “virtual room”. This parameter allows you to aurally place an omnidirectional signal source so that the sound appears to be coming from the front area of the room (from the listener’s perspective), from the rear, or

somewhere in between. To aurally place the signal source to the front in the room, select “F”. To aurally place the signal source to the rear in the room, select “r”. To aurally place the signal source so that it is on centered between front and rear in the room, select “0”. Please note that the values between “F” and “0” are displayed on the left portion of the display, to indicate that the signal source is aurally placed to the front of center in the room, and the values between “0” and “r” are displayed in the right portion of the display, to indicate that the signal source is aurally placed to the rear of center in the room.

PARAMETER 64: LISTENER LOCATION L/R

This is an EARLY REFLECTIONS MODULE (room simulation program) parameter. This parameter is calculated from the sound reflections that would occur in a “virtual room”. This parameter allows you to aurally place the listener to the far left in the room, the far right in the room, or anywhere in between. To aurally position the listener so that the listener appears to be to the far left in the room, select “L”. To aurally position the listener so that the listener appears to be to the far right in the room, select “r”. To aurally position the listener so that the listener appears centered between the left and right areas in the room, select “0”. Please note that the values between “L” and “0” are displayed on the left portion of the display, to indicate that the listener is aurally placed to the left of center in the room, and the values between “0” and “r” are displayed in the right portion of the display, to indicate that the listener is aurally placed to the right of center in the room.

PARAMETER 65: LISTENER LOCATION L/R

This is an EARLY REFLECTIONS MODULE (room simulation program) parameter. This parameter is calculated from the sound reflections that would occur in a “virtual room”. This parameter allows you to aurally place the listener to the front area of the room, to the rear, or somewhere in between. To aurally place the listener to the front in the room, select “F”. To aurally place the listener to the rear in the room, select “r”. To aurally place the listener in a position centered between front and rear in the room, select “0”. Please note that the values between “F” and “0” are displayed on the left portion of the display, to indicate that the listener is aurally placed to the front of center in the room, and the values between “0” and “r” are displayed in the right portion of the display, to indicate that the listener is aurally placed to the rear of center in the room.

PARAMETER 66: REFLECTION COEFFICIENT

This is an EARLY REFLECTIONS MODULE (room simulation program) parameter. This parameter adjusts how much reflectivity your “virtual room” will have. The higher you set this parameter, the greater the number of reflections you will get, bouncing back and forth between the walls and other surfaces of your “virtual room”. This parameter may be varied from “.00”, for no reflectivity, up to “1.00”, for maximum reflectivity.

PARAMETER 67: EAR WIDTH

This is an EARLY REFLECTIONS MODULE (room simulation program) parameter. This parameter makes your ears wider (just kidding!). This parameter adjusts the distance between the ears (receivers) of the listener in your “virtual room”. This parameter may be varied from “.0” to “10.0” meters.

PARAMETER 68: EXTERNAL TAP SWITCH OPTION

This parameter assigns external tap switch control to one or both delays, or disables the external tap switch control. The choices are listed below.

To use the tap tempo input of the 606, connect your footswitch to the 1/4" footswitch input jack on the rear of the 606. You may use either a normally open or a normally closed footswitch. Now, power up the 606 (to use the footswitch, the 606 must be powered up with the footswitch connected, so that the 606's software can “read” the footswitch input to see if it is a normally open or normally closed footswitch) and select preset 68 (External Tap Switch Option). Now, you will

Delay F/x
Machine

606

need to select which delay(s) that you want the tap footswitch to affect. The options are as follows:

- OFF** The tap footswitch is not enabled.
- dL1** The tap footswitch will set the delay time of Delay 1 only.
- dL2** The tap footswitch will set the delay time of Delay 2 only.
- d12** The tap footswitch will set the delay time of Delay 1 and Delay 2 (both will be set to the same delay time).
- 12r** Delay 1 and Delay 2 proportional. The tap footswitch sets the delay time of Delay 1, and Delay 2 is changed in such a manner that the original proportion between Delay 1 and Delay 2 is maintained (for example, if Delay 1 was originally set to 100 ms., and Delay 2 was originally set to 200ms., then if the tap switch was used to set Delay 1 to 400ms., Delay 2 would be automatically set to 800 ms., so that the 1:2 proportion between Delay 1's delay time and Delay 2's delay time would be maintained).
- 21r** Delay 2 and Delay 1 proportional. The tap footswitch sets the delay time of Delay 2, and Delay 1 is changed in such a manner that the original proportion between Delay 2 and Delay 1 is maintained (for example, if Delay 2 was originally set to 200 ms., and Delay 1 was originally set to 100 ms., then if the tap switch was used to set Delay 2 to 400 ms., Delay 1 would be automatically set to 200 ms.

The tap tempo input requires at least four consecutive taps of the footswitch before the 606 will adapt to the tempo being tapped on the footswitch. Less than four taps will not trigger the 606 to adjust to the tapped tempo. The 606 averages the tempo of the four taps, and responds to this averaged tempo. If the footswitch is tapped continuously, the 606 will continue to average and respond to the taps at its footswitch input. However, once the tapping is discontinued for three seconds or longer, it will take four consecutive taps to get the 606 to start responding again to tempo changes tapped at the footswitch input.

PARAMETER 69: MEMORY WIDTH

This parameter selects the resolution of the memory or enables the EARLY REFLECTIONS MODULE (room simulation program). The choices for memory resolution are: "24" (24-bit) and "16" (16-bit). When 24-bit memory resolution is selected, you will have higher resolution than with 16-bit, but the maximum delay length per channel will be less (1.35 seconds maximum delay length per channel using 24-bit resolution). When 16-bit memory resolution is selected, you will have lower resolution than with 24-bit, but the maximum delay length per channel will be greater (2.74 seconds maximum delay length per channel using 16-bit resolution). Please note that this parameter only adjusts the resolution of the memory. The resolution of the 606's DSP is always 24-bit.

If you select "ERL", which enables the EARLY REFLECTIONS MODULE, the memory resolution will be automatically set to 16-bit. Parameters 60-67 control various aspects of the EARLY REFLECTIONS MODULE.

PARAMETER 70: MIDI CLOCK 1

This parameter sets the length of DELAY LINE 1 in direct proportion to the MIDI beats per minute rate, so that the delay can be exactly in time with the music being played via MIDI. The MIDI beats per minute rate is dictated by the MIDI clock signal being fed to the 606's MIDI IN jack. Musically speaking, one MIDI beat equals one whole note. The MIDI Clock 1 parameter corresponds to the MIDI CLK SYNC knob for DELAY LINE 1 (top command line), so it can be adjusted by this knob, or by accessing Parameter 70 through the GLOBAL section. The parameter options are as follows:

- OFF** MIDI Clock 1 control is not enabled.
- 4 b** The length of one delay will equal four MIDI beats (**four whole notes**).

- 3 b** The length of one delay will equal three MIDI beats (**three whole notes**).
- 2 b** The length of one delay will equal two MIDI beats (**two whole notes**).
- 1 b** The length of one delay will equal one MIDI beat (**a whole note**).
- 2** The length of one delay will equal one **half-note**.
- 2.3** The length of one delay will equal the length of one note of a **half-note triplet**.
- 4** The length of one delay will equal the length of **one quarter-note**.
- 4.3** The length of one delay will equal the length of one note of a **quarter-note triplet**.
- 8** The length of one delay will equal the length of **one eighth-note**.
- 8.3** The length of one delay will equal the length of one note of an **eighth-note triplet**.

PARAMETER 71: MIDI CLOCK 2

This parameter sets the length of DELAY LINE in. direct proportion to the MIDI beats per minute rate, so that the delay can be exactly in time with the music being played via MIDI. The MIDI beats per minute rate is dictated by the MIDI clock signal being fed to the 606's MIDI IN jack. Musically speaking, one MIDI beat equals one whole note. The MIDI Clock 2 parameter corresponds to the MIDI CLK SYNC knob for DELAY LINE 2 (top command line), so it can be adjusted by this knob, or by accessing Parameter 71 through the GLOBAL section. The parameter options are as follows:

- OFF** MIDI Clock 2 control is not enabled.
- 4 b** The length of one delay will equal four MIDI beats (**four whole notes**).
- 3 b** The length of one delay will equal three MIDI beats (**three whole notes**).
- 2 b** The length of one delay will equal two MIDI beats (**two whole notes**).
- 1 b** The length of one delay will equal one MIDI beat (**one whole note**).
- 2** The length of one delay will equal **one half-note**.
- 2.3** The length of one delay will equal the length of one note of a **half-note triplet**.
- 4** The length of one delay will equal the length of **one quarter-note**.
- 4.3** The length of one delay will equal the length of one note of a **quarter-note triplet**.
- 8** The length of one delay will equal the length of **one eighth-note**.
- 8.3** The length of one delay will equal the length of one note of an **eighth-note triplet**.

Please note that “4 b”, “3 b”, “2 b”, and “1 b” appear in the left half of the display, to indicate that they are multipliers. Please also note that “2”, “2.3”, “4”, “4.3”, “8”, and “8.3” appear in the right half of the display, to indicated that they are dividers.

PARAMETER 72: MIDI CLOCK DIVIDE

This parameter sets the MIDI resolution so that you can match the 606's resolution to the resolution of your other MIDI equipment. The options are:

- 24** 24 clock divisions per beat.
- 48** 48 clock divisions per beat.
- 96** 96 clock divisions per beat.

PARAMETER 73: DIFFUSION MODEL DELAY 1

This parameter selects a diffusion model for DELAY LINE 1. The diffusion model simulates the size of a “virtual room”. This allows you to hear the sound diffuse as it would if you were standing in a room of the selected size. This parameter corresponds to the DIFFUSION 1 MODEL knob

(top command line), so it can be adjusted by this knob, or by accessing Parameter 73 through the GLOBAL section. The diffusion model options are:

- Sn1** Small room diffusion simulation number 1.
- Sn2** Small room diffusion simulation number 2.
- NE1** Medium room diffusion simulation number 1.
- NE2** Medium room diffusion simulation number 2.
- LG1** Large room diffusion simulation number 1.
- LG2** Large room diffusion simulation number 2.

PARAMETER 74: DIFFUSION MODEL DELAY 2

This parameter selects a diffusion model for DELAY LINE 2. The diffusion model simulates the size of a “virtual room”. This allows you to hear the sound diffuse as it would if you were standing in a room of the selected size. This parameter corresponds to the DIFFUSION 2 MODEL knob (top command line), so it can be adjusted by this knob, or by accessing Parameter 74 through the GLOBAL section. The diffusion model options are:

- Sn1** Small room diffusion simulation number 1.
- Sn2** Small room diffusion simulation number 2.
- NE1** Medium room diffusion simulation number 1.
- NE2** Medium room diffusion simulation number 2.
- LG1** Large room diffusion simulation number 1.
- LG2** Large room diffusion simulation number 2.

PARAMETER 75: NAME 0

Parameters 75-77 allow you to create your own preset names, up to 3 characters in length. Parameter 75 sets the 1st character of the preset name. As you adjust Parameter 75, you will be able to select from a variety of characters. To assign a name to a preset, load the preset that you wish to rename. Select Parameter 75, and adjust this parameter until the desired first character of the name appears. Press “SAVE”. If “Prt” appears in the window, then the Memory Protection is enabled, and you will not be allowed to save the new character until you turn off the Memory Protection, which is accessible through Parameter 80. If the Memory Protection was already disabled when you pressed “SAVE”, then your new character should now be entered into memory as the first character of the preset name.

PARAMETER 76: NAME 1

Parameters 75-77 allow you to create your own preset names, up to 3 characters in length. Parameter 76 sets the 2nd character of the preset name. As you adjust Parameter 76, you will be able to select from a variety of characters. To assign a name to a preset, load the preset that you wish to rename. Select Parameter 76, and adjust this parameter until the desired second character of the name appears. Press “SAVE”. If “Prt” appears in the window, then the Memory Protection is enabled, and you will not be allowed to save the new character until you turn off the Memory Protection, which is accessible through Parameter 80. If the Memory Protection was already disabled when you pressed “SAVE”, then your new character should now be entered into memory as the second character of the preset name.

PARAMETER 77: NAME 2

Parameters 75-77 allow you to create your own preset names, up to 3 characters in length. Parameter 77 sets the 3rd character of the preset name. As you adjust Parameter 77, you will be able to select from a variety of characters. To assign a name to a preset, load the preset that you wish to

rename. Select Parameter 77, and adjust this parameter until the desired third character of the name appears. Press “SAVE”. If “Prt” appears in the window, then the Memory Protection is enabled, and you will not be allowed to save the new character until you turn off the Memory Protection, which is accessible through Parameter 80. If the Memory Protection was already disabled when you pressed “SAVE”, then your new character should now be entered into memory as the third character of the preset name.

PARAMETER 78: MIDI CHANNEL

This parameter determines to which MIDI channel the 606 will respond. You have the option of selecting any channel from 1 to 16 (Omni Off mode, the display will show the number of the selected channel), or all channels simultaneously (Omni On mode, the display will read “ALL”).

PARAMETER 79: MIDI UNIT

This parameter sets the SysEx unit number for your Symetrix 606. This identifies your 606 so that SysEx commands can be directed to your 606. If you have more than one 606, you can assign a different SysEx unit number to each 606, so that SysEx commands can be directed to a specific 606. You have the option of assigning any unit number from 1 to 126 (the display will show the selected number), or all unit numbers (the display will read “All”).

PARAMETER 80: MEMORY PROTECT

This parameter determines whether the 606 will allow you to overwrite or alter a preset. Please note that the last ten presets (100-109) are building-block presets that cannot be overwritten or altered. The choices for this parameter are:

OFF Memory Protection is turned off. You will be allowed to alter or overwrite presets (except for the last ten presets).

Prt Memory Protection is turned on. You will not be allowed to alter or overwrite presets.

If you try to save changes to a preset, and the display reads “Prt”, then the Memory Protection is turned on. You will not be allowed to save your changes until you use Parameter 80 to turn the Memory Protection off.

606 Delay F/x Machine

Specifications**Audio**

Number of audio channels	2 (coupled or dual mono)
Connectors	¼" TRS style
Maximum input level	+25 dBu
Maximum output level	+20 dBu
Input impedance	20K Balanced, 10K Unbalanced
Output impedance	600 Ohms Balanced
THD + Noise @1kHz	-90 dBFS
Dynamic range	>90 dB
Frequency response	+/-1 dBm (20 Hz to 20 kHz)
Number of programs	99 - User programs 10 - Nonvolatile programs
Midi controls	Key on, Parameter Control, Programs SysEx, Dump & Load

Physical

Chassis size	1.72"H x 19"W x 4.25"D
Shipping weight	5lbs

This product is intended for use in a rack-mounted environment.

Electrical

Requirements for US/Canadian models:	117 VAC Nominal 105 to 125 VAC, 60 Hz 12 Watts maximum
--------------------------------------	--

UL and C-UL listing applies only to the US/Canadian rating.

Requirements for Export models :	220 VAC Nominal 205 to 225 VAC, 50 Hz 12 Watts maximum
----------------------------------	--

*In the interest of continuous product improvement, Symetrix, Inc. reserves the right to alter, change, or modify these specifications without prior notice.
Copyright, 1997, Symetrix, Inc. All rights reserved.*

6006
Delay F/x
Machine

There is no output signal.

Check the AC power connections to the 606.

Check input and output cables and connections.

Determine that there really is a signal coming from the source, and that it is getting to the 606.

Make sure that the Input LEVEL control is turned up enough so that at least the SIGNAL and -12dB LEDS on the input meter are lighting. Hint - try setting this control to 12 o'clock.

Make sure that the OUTPUT LEVEL (bottom command line) is turned up.

Hint - try setting the output level to "0.0", which is unity gain.

Set the 606 in "bypass" mode, by quickly pressing the LOAD button twice. If you still have no output signal, the problem is probably external to the 606. You can set the 606 back to "operate" mode by pressing the LOAD button once more.

There is distortion in the output signal.

Check the input signal. Is the 606's CLIP LED lighting? If so, turn down the Input LEVEL control.

Is the incoming signal already distorted? Listen "up stream" from the 606 to determine if you are feeding it a clean signal.

There is a buzz in the output.

Check input and output connector wiring.

Check for ground loops between interconnected system equipment.

Make sure that all system components are on the same AC ground.

The output is noisy.

Check the settings of the Input LEVEL control and the OUTPUT LEVEL control. Try setting the OUTPUT LEVEL control to "0.0", and then adjust the Input LEVEL control to give you the desired signal level. The Input Level LED display should indicate signal up to, but not including, the CLIP LED.

Make sure that the incoming signal is line-level.

Is the input signal already noisy? Listen "up stream" from the 606 to determine if you are feeding it a clean signal.

My new preset won't "save".

Make sure that you are saving to a preset location other than locations #100-109 (ROM).

Make sure that Parameter 80 (memory protection) is set to "OFF".

There is no LED display.

Is the 606 plugged in to AC power?

Is the AC power outlet OK?

The 606 is not responding.

Is the 606 in BYPASS mode? If so, press the LOAD button once to get out of BYPASS mode.

NOTE: *When the 606 is in BYPASS mode, the window display will be flashing "out".*

Check to see that you have the MIX controls set for at least 50% "wet" signal at the delay outputs.

Check the DELAY TIME settings, to make sure that they are not set to "0.0", or set for delay times that are so short that you cannot hear the delay effects.

NOTE: *Try DELAY TIME settings of at least 100 ms. when you are verifying that delay is occurring. Once you have verified the delay, you may return to shorter delay settings.*

The 606 is not plugged in, but it works anyway.

Call us. Call us right now.

Delay F/x
Machine

606

606 LIMITED WARRANTY

Symetrix, Inc. expressly warrants that the product will be free from defects in material and workmanship for one (1) year. Symetrix’s obligations under this warranty will be limited to repairing or replacing, at Symetrix’s option, the part or parts of the product which prove defective in material or workmanship within one (1) year from date of purchase, provided that the Buyer gives Symetrix prompt notice of any defect or failure and satisfactory proof thereof. Products may be returned by Buyer only after a Return Authorization number (RA) has been obtained from Symetrix. Buyer will prepay all freight charges to return the product to the Symetrix factory. Symetrix reserves the right to inspect any products which may be the subject of any warranty claim before repair or replacement is carried out. Symetrix may, at its option, require proof of the original date of purchase (dated copy of original retail dealer's invoice). Final determination of warranty coverage lies solely with Symetrix. Products repaired under warranty will be returned freight prepaid by Symetrix via United Parcel Service (surface), to any location within the Continental United States. At Buyer’s request the shipment may be returned via airfreight at Buyer’s expense. Outside the Continental United States, products will be returned freight collect.

The foregoing warranties are in lieu of all other warranties, whether oral, written, express, implied or statutory. Symetrix, Inc. expressly disclaims any IMPLIED warranties, including fitness for a particular purpose or merchantability. Symetrix’s warranty obligation and buyer’s remedies hereunder are SOLELY and exclusively as stated herein.

This Symetrix product is designed and manufactured for use in professional and studio audio systems and is not intended for other usage. With respect to products purchased by consumers for personal, family, or household use, Symetrix **expressly disclaims all implied warranties, including but not limited to warranties of merchantability and fitness for a particular purpose.**

This limited warranty, with all terms, conditions and disclaimers set forth herein, shall extend to the original purchaser and anyone who purchases the product within the specified warranty period.

Warranty Registration must be completed and mailed to Symetrix within thirty (30) days of the date of purchase.

Symetrix does not authorize any third party, including any dealer or sales representative, to assume any liability or make any additional warranties or representation regarding this product information on behalf of Symetrix.

This limited warranty gives the buyer certain rights. You may have additional rights provided by applicable law.

Limitation of Liability

The total liability of Symetrix on any claim, whether in contract, tort (including negligence) or otherwise arising out of, connected with, or resulting from the manufacture, sale, delivery, resale, repair, replacement or use of any product will not exceed the price allocable to the product or any part thereof which gives rise to the claim. In no event will Symetrix be liable for any incidental or consequential damages including but not limited to damage for loss of revenue, cost of capital, claims of customers for service interruptions or failure to supply, and costs and expenses incurred in connection with labor, overhead, transportation, installation or removal of products or substitute facilities or supply houses.

606 Delay F/x Machine

SERVICING THE 606

If you have determined that your 606 requires repair services and you live *outside* of the United States please contact your local Symetrix dealer or distributor for instructions on how to obtain service. If you reside in the U.S. then proceed as follows:

Return authorization

At the Symetrix factory, Symetrix will perform in-warranty or out-of-warranty service on any product it has manufactured for a period of five years from date of manufacture.

Before sending anything to Symetrix, contact our Customer Service Department for a return authorization (RA) number. The telephone number is (425) 787-3222, Monday through Friday, 8AM (800 hours) though 4:30 PM (1630 hours), Pacific Time.

In-warranty repairs

To get your 606 repaired under the terms of the warranty:

1. Call us for an RA number.
2. Pack the unit in its original packaging materials.
3. Include your name, address, daytime telephone number, and a brief statement of the problem.
4. Write the RA number on the outside of the box.
5. Ship the unit to Symetrix, freight prepaid. We do *not* accept freight collect shipments.

Just do these five things, and repairs made in-warranty will cost you only one-way freight charges. We'll prepay the return (surface) freight.

If you choose to send us your product in some sort of flimsy packaging, we'll have to charge you for proper shipping materials. If you don't have the factory packaging materials, then do yourself a favor by using an oversize carton, wrap the unit in a plastic bag, and surround it with bubble-wrap. Pack the box full of Styrofoam peanuts. Be sure there is enough clearance in the carton to protect the rack ears (you wouldn't believe how many units are returned with bent ears). We won't return the unit in anything but Symetrix packaging for which we will have to charge you. Of course, if the problem turns out to be operator inflicted, you'll have to pay for both parts and labor. In any event, if there are charges for the repair costs, you will pay for the return freight. All charges will be COD unless you have made other arrangements (prepaid, Visa or Mastercard).

Out-of-warranty repairs

If the warranty period has passed, you'll be billed for all necessary parts, labor, packaging materials, and freight charges. Please remember, you must call for an RA number before sending the unit to Symetrix.

Delay F/x
Machine
606

With the exception of the analog Input LEVEL control and parameters 78 thru 80, every parameter within the 606 is available for external control via MIDI. This includes not only program change, but also complete memory dump storage via System Exclusive (SysEx).

To dump the presets to a storage medium, simply press and hold the SELECT button. The display will count up by 10's from 10 to 90, and then will read "End" once the download is complete. This will dump the entire memory through the MIDI OUT/THRU port.

If you only wish to dump the contents of the edit buffer (the currently loaded preset) to a storage medium, then first press and hold in the MODE button. Next, while you are holding in the MODE button, press and hold in the SELECT button. The display will read "End" when the download is complete.

To load information on the 606 via SysEx, simply send the information through the 606's MIDI IN port, and the 606 will respond automatically.

The MIDI-specific parameters of the 606 are: MIDI Clock 1 (Parameter 70), MIDI Clock 2 (Parameter 71), MIDI Clock Divide (Parameter 72), MIDI Channel (Parameter 78), and MIDI Unit (Parameter 79). Please refer to Chapter 10 of this manual for more information on these parameters.

The MIDI Control Change input number for each parameter is equal to the Parameter number shown in Appendix C plus twenty. For a list of the 606's MIDI-controllable parameters, and their corresponding MIDI Control Change input numbers, please see the Parameter Chart (Appendix C).

KEY ON/OFF SUPPORTED

SUPPORTED CONTROL CHANGE CODES:

<u>Control Code (decimal)</u>	<u>Definition</u>	<u>Modulation Source Name</u>
01	modulation	'mod'
02	breath control	'brh'
04	foot controller	'fc'
07	volume	'vol'
08	balance	'bal'
10	pan	'pan'
20-100	mapping of front panel parameters 0-80	

SUPPORTED SYSEX CODES:

Request Single Byte Out Of Edit Buffer:

<u>Code (hex)</u>	<u>Description</u>
F0	SysEx start
00 00 5E	Symetrix manufacturer's number
06	device type
<unit number>	SysEx MIDI unit number (0-126, 127:ALL)
11	command code
<offset>	offset of data in edit buffer
F7	SysEx end

Returns:

<u>Code (hex)</u>	<u>Description</u>
F0	SysEx start
00 00 5E	Symetrix manufacturer's number
06	device type
<unit number>	SysEx MIDI unit number (0-126, 127:ALL)

01	command code
<offset>	data offset
<data>	edit buffer data
F7	SysEx end

Request Program Dump:

<u>Code (hex)</u>	<u>Description</u>
F0	SysEx start
00 00 5E	Symetrix manufacturer's number
06	device type
<unit number>	SysEx MIDI unit number (0-126, 127:ALL))
12	command code
<starting block, 0 = edit buffer, 110 (6E) = machine setup>	
<number of blocks>	
F7	SysEx end

Returns:

<u>Code (hex)</u>	<u>Description</u>
F0	SysEx start
00 00 5E	Symetrix manufacturer's number
06	device type
<unit number>	SysEx MIDI unit number (0-126, 127:ALL)
1D	command code
<starting block, 0 = edit buffer, 110 = machine setup>	
<number of blocks>	
< data >	data
...	data
F7	SysEx end

Request Status:

<u>Code (hex)</u>	<u>Description</u>
F0	SysEx start
00 00 5E	Symetrix manufacturer's number
06	device type
<unit number>	SysEx MIDI unit number (0-126, 127:ALL)
1F	command code
F7	SysEx end

Returns:

<u>Code (hex)</u>	<u>Description</u>
F0	SysEx start
00 00 5E	Symetrix Manufacturer's number
06	device type
<unit number>	SysEx MIDI unit number (0-126, 127:ALL)
0F	command code
<left input level, MSB byte>	
<left input level, LSB byte>	
<right input level, MSB byte>	
<right input level, LSB byte>	
<bit0: 'dual mono led' on, bit1: 'coupled' led on>	
F7	SysEx end

Delay F/x
Machine
6006

Set Byte Into Edit Buffer:

<u>Code (hex)</u>	<u>Description</u>
F0	SysEx start
00 00 5E	Symetrix manufacturer's number
06	device type
<unit number>	SysEx MIDI unit number (0-126, 127: ALL)
1C	command code
<offset>	edit buffer location offset
<data>	data
F7	SysEx end

Send Program Buffer:

<u>Code (hex)</u>	<u>Description</u>
F0	SysEx start
00 00 5E	Symetrix manufacturer's number
06	device type
<unit number>	SysEx MIDI unit number (0-126,127:ALL)
1D	command code
<starting block, 0 = edit buffer, 110 = machine setup>	
<number of blocks>	
< data >	data
...	data
F7	SysEx end

Copy Edit Buffer to Program Store:

<u>Code (hex)</u>	<u>Description</u>
F0	SysEx start
00 00 5E	Symetrix manufacturer's number
06	device type
<unit number>	SysEx MIDI unit number (0-126, 127:ALL)
1E	command code
<program to store 0-98>	corresponds to memory locations 1-99
F7	SysEx end

Offsets For Each Program Block:

<u>MIDI Offset(dec)</u>	<u>Range(dec)</u>	<u>Description</u>
00	0-127	block 1 dry-wet mix
01	0-127	block 1 feedback
02	0-127	block 1 modulation level
03	0-127	block 2 dry-wet mix
04	0-127	block 2 feedback
05	0-127	block 2 modulation level
06	0-127	input channel 1 to output bus pan
07	0-127	input channel 2 to output bus pan
08	0-127	delay block 1 dry source segue
09	0-7	delay block 1 filter type
10	0-107	delay block 1 filter frequency
11	0-29	delay block 1 filter sharpness
12	0-127	delay block 1 delay time - MSB 7 bits
13	0-127	delay block 1 delay time - MIDHI 7 bits

MIDI Offset(dec)	Range(dec)	Description
14	0-127	delay block 1 delay time - MIDLO 7 bits
15	0-127	delay block 1 delay time - LSB 7 bits
16	0-2	delay block 1 feedback signal source
17	0-127	delay block 1 feedback segue
18	0-2	delay block 1 wet signal source
19	0-127	delay block 1 wet pan to output bus
20	0-127	delay block 1 wet attenuation
21	0-10	delay block 1 MIDI clock divider
22	0-1	delay block 2 dry input signal source
23	0-127	delay block 2 dry source segue
24	0-7	delay block 2 filter type
25	0-107	delay block 2 filter frequency
26	0-29	delay block 2 filter sharpness
27	0-127	delay block 2 delay time - MSB 7 bits
28	0-127	delay block 2 delay time - MIDHI 7 bits
29	0-127	delay block 2 delay time - MIDLO 7 bits
30	0-127	delay block 2 delay time - LSB 7 bits
31	0-2	delay block 2 feedback signal source
32	0-127	delay block 2 feedback segue
33	0-2	delay block 2 wet signal source
34	0-127	delay block 2 wet pan to output bus
35	0-127	delay block 2 wet attenuation
36	0-10	delay block 2 MIDI clock divider
37	0-16	modulator 1 source
38	0-16	modulator 1 destination
39	0-127	modulator 1 level
40	0-16	modulator 2 source
41	0-16	modulator 2 destination
42	0-127	modulator 2 level
43	0-16	modulator 3 source
44	0-16	modulator 3 destination
45	0-127	modulator 3 level
46	0-16	modulator 4 source
47	0-16	modulator 4 destination
48	0-127	modulator 4 level
49	0-16	modulator 5 source
50	0-16	modulator 5 destination
51	0-127	modulator 5 level
52	0-16	modulator 6 source
53	0-16	modulator 6 destination
54	0-127	modulator 6 level
55	0-127	triangle/saw oscillator 1 frequency
56	0-127	triangle/saw oscillator 2 frequency
57	0-127	triangle oscillator 3 frequency
58	0-127	triangle oscillator 4 frequency
59	0-127	random generator 1 rate
60	0-43	random generator 1 smoothing
61	0-127	random generator 2 rate
62	0-43	random generator 2 smoothing
63	0-5	logarithmic converter signal src
64	0-43	logarithmic convertor smoothing

Delay F/x Machine 606

<u>MIDI Offset(dec)</u>	<u>Range(dec)</u>	<u>Description</u>
65	0-15	room size model
66	0-127	room signal source L/R
67	0-127	room signal source F/B
68	0-127	room listener L/R
69	0-127	room listener F/B
70	0-127	room reflection coefficient
71	0-100	room listener CH1/2L/R separation
72	0-127	room reflection level attenuation
73	0-5	block 1 diffusion model
74	0-5	block 2 diffusion model
75	0-16	diffusion 1 depth
76	0-16	diffusion 2 depth
77	0-5	foot switch mode
78	0-2	memory model
79	0-80	menu level 2 parameter number
80-95		16 character name

Global Area Setup:

00	0-127	output attenuation
01	0-16	MIDI channel (0-15, 16:ALL)
02	0-127	MIDI unit (0-126, 127: ALL)
03	0-109	current running program
04	0-1	memory protection (0:OFF, 1:ON)
05	0-2	MIDI clock division (0:24, 1: 48, 2: 96)
06	0-2	current front panel level (0-2)
07	0-1	front panel lock (0: NO, 1: YES)
08	0-1	program modified (0: NO, 1: YES)

<u>Block Number(dec)</u>	<u>Buffer type</u>
00	Edit Buffer
01-99	User RAM programs 1-99
100-109	Factory ROM programs 1-10
110	Global setup

NOTE: When the front panel shows an “Er<n>” message there has been a MIDI communication error detected. <n> is a hex number representing the or’d bits for the following errors:

MIDI buffer overrun: bit 0

framing error : bit 1

MIDI UART overrun: bit 3

For example, an error indication of “Er3” indicates a MIDI buffer overrun and a framing error.



6006

**Delay F/x
Machine**



606 DELAY F/x MACHINE Flowchart

(X) = PARAMETER NUMBER
 (X) = PARAMETER NUMBER (ALSO FRONT PANEL CONTROL)
 NOTE: PARAMETER NUMBER +20 IS EQUAL TO THE MIDI CONTINUOUS CONTROLLER NUMBER

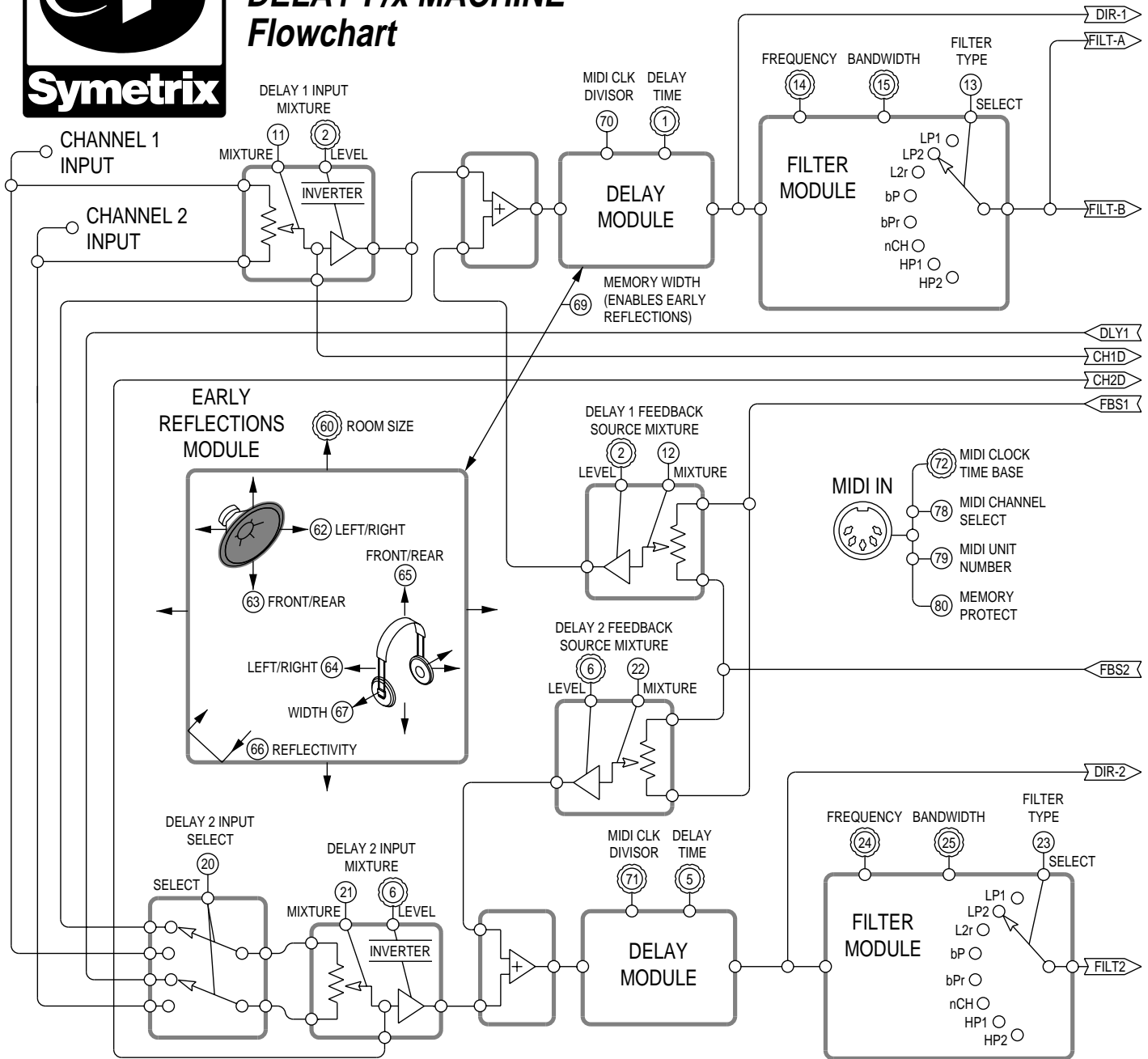

MODULATION SOURCES

- RATE (50) 7r1 = TRIANGLE GEN 1
- 5A1 = SAWTOOTH GEN 1
- RATE (51) 7r2 = TRIANGLE GEN 2
- 5A2 = SAWTOOTH GEN 2
- RATE (52) 7r3 = TRIANGLE GEN 3
- RATE (53) 7r4 = TRIANGLE GEN 4

- RATE (54) r n 1 = RANDOM GEN 1
- SMOOTH (55)
- RATE (56) r n 2 = RANDOM GEN 2
- SMOOTH (57)
- SOURCE (58) L o b = LOG CONVERTER
- SMOOTH (59)

- MIDI CONTROLLERS
- mod = MOD WHEEL (1)
 - brh = BREATH CONTROLLER (2)
 - Frc = FOOT CONTROLLER (4)
 - vol = MIDI VOLUME (7)
 - bal = MIDI BALANCE (8)
 - pan = MIDI PAN (10)
 - chn = POS MIDI NOTE
 - blo = NEG MIDI NOTE

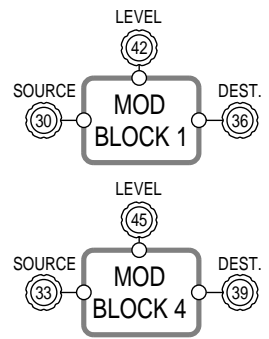

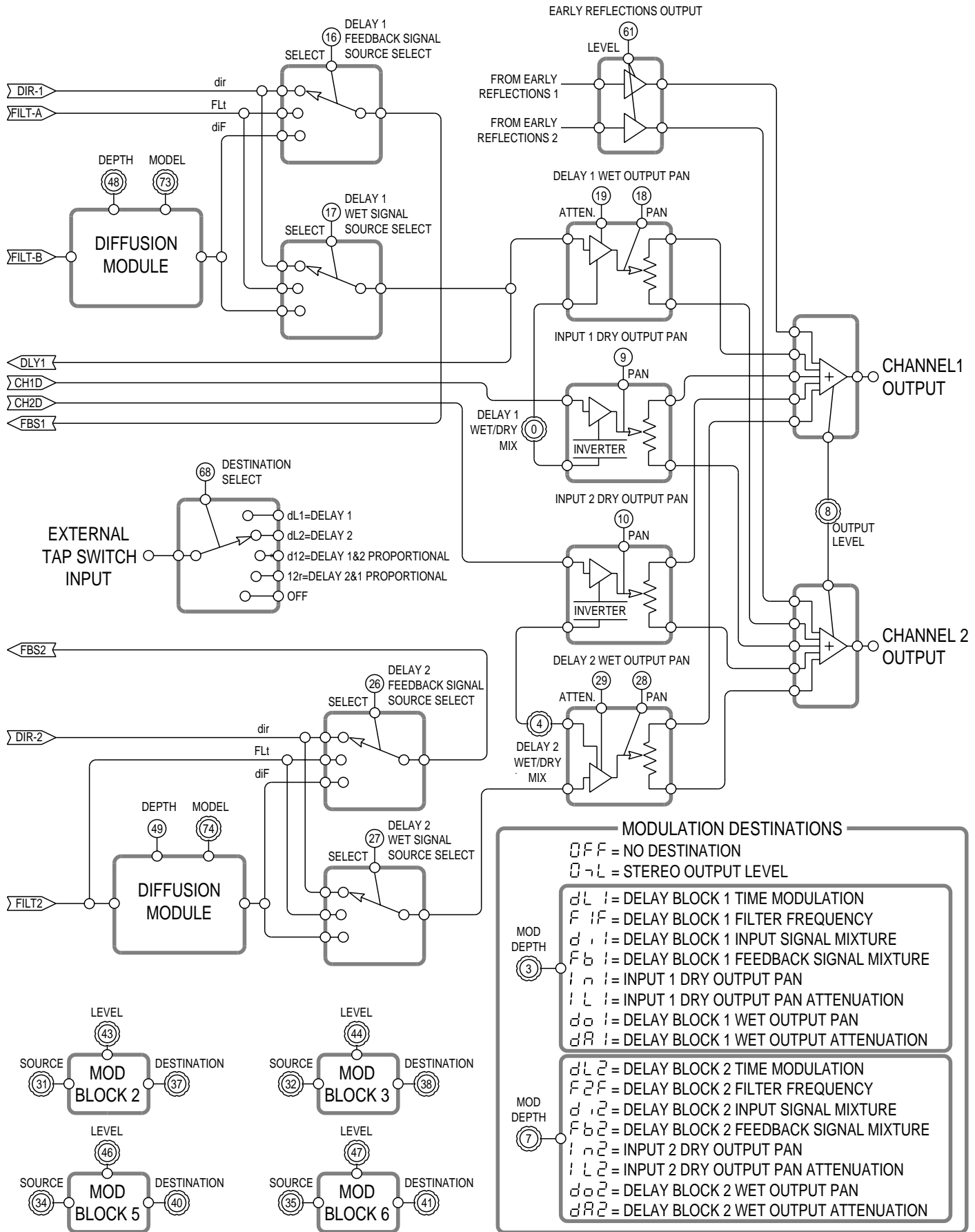

MODULATION DESTINATIONS

OFF = NO DESTINATION
 0 - L = STEREO OUTPUT LEVEL

MOD DEPTH 3	dL 1 = DELAY BLOCK 1 TIME MODULATION
	F 1F = DELAY BLOCK 1 FILTER FREQUENCY
	d , 1 = DELAY BLOCK 1 INPUT SIGNAL MIXTURE
	F b 1 = DELAY BLOCK 1 FEEDBACK SIGNAL MIXTURE
	I n 1 = INPUT 1 DRY OUTPUT PAN
	I L 1 = INPUT 1 DRY OUTPUT PAN ATTENUATION
MOD DEPTH 7	dL 2 = DELAY BLOCK 2 TIME MODULATION
	F 2F = DELAY BLOCK 2 FILTER FREQUENCY
	d , 2 = DELAY BLOCK 2 INPUT SIGNAL MIXTURE
	F b 2 = DELAY BLOCK 2 FEEDBACK SIGNAL MIXTURE
	I n 2 = INPUT 2 DRY OUTPUT PAN
	I L 2 = INPUT 2 DRY OUTPUT PAN ATTENUATION
dO 2 = DELAY BLOCK 2 WET OUTPUT PAN	
dR 2 = DELAY BLOCK 2 WET OUTPUT ATTENUATION	

Parameter Chart

Appendix C

Parameter <i>FP= front panel knob</i>	MIDI Ctrl#	Title	Description	Control Range
0 FP	20	Dry/Wet Mix - Delay 1	Controls wet/dry mix	0 - 100%
1 FP	21	Delay Time for Delay 1	Increase/Decrease Delay Time	0 - 1.3 secs high res., 0 - 2.6 secs low res
2 FP	22	Feedback Amount Delay 1	Resonance for Delay 1	-1.0 - Off - 1.0
3 FP	23	Modulation Level for Delay 1	Global level for all modulators affecting Delay 1.	0 - 100%
4 FP	24	Dry/Wet Mix - Delay 2	Controls wet/dry mix	0 - 100%
5 FP	25	Delay Time for Delay 2	Increase/Decrease delay time	0 - 1.3 secs high res., 0 - 2.6 secs low res
6 FP	26	Feedback Amount Delay 2	Resonance for Delay 2	-1.0 - Off - 1.0
7 FP	27	Modulation Level for Delay 2	Global modulation level for Delay 2	0 - 100%
8 FP	28	Output Attenuation	Global volume attenuator	0db - Off
9	29	Channel 1 Dry Input panned to Output Bus	Destination of dry signal from input 1 to output 1 or output 2	Ch1 output panning through 0 (both) to Ch2 output
10	30	Channel 2 Dry Input panned to Output Bus	Destination of dry signal from input 2 to output 1 or output 2	Ch1 output panning through 0 (both) to Ch2 output
11	31	Delay 1 Source	Determines which inputs feed Delay 1	Pan from Ch1 thru 0 to Ch2
12	32	Delay 1 Feedback Source Mix	Selects which delay will feed Delay 1 Feedback	Delay 1 thru 0 (both) to Delay 2
13	33	Delay 1 Filter Type	Selects type of filter used on Delay 1	LP1, LP2, L2R, BP, BPR, NCH, HP1, HP2
14 FP	34	Delay 1 Filter Frequency	Selects frequency of filter chosen in #13	46 Hz - 21.0 kHz
15 FP	35	Delay 1 Filter Q	Q of Filter 1	.70 - 107
16	36	Delay 1 Feedback Signal Source Select	Determines route of signal returned to Delay 1	dir (direct), flt (filter), dif (diffusion)
17	37	Delay 1 Wet Signal	Determines route of wet signal out of Delay 1	dir (direct), flt (filter), dif (diffusion)
18	38	Delay 1 Wet Pan	Destination of wet signal from Delay 1 to outputs	Ch1 thru 0 to Ch2
19	39	Delay 1 Wet Attenuation	Delay 1 wet volume	0db - Off
20	40	Delay 2 Input Source	Determines input of D2	Dry Inputs or Delay 1
21	41	Delay 2 Source	Determines which input will feed Delay 2	Pan from Ch1 thru 0 to Ch2 or Delay 1 Input to Output of Delay 1 Wet Signal
22	42	Delay 2 Feedback Source Mix	Determines which delay will feed Delay 2 Feedback	Delay 1 thru 0 (both) to Delay 2
23	43	Delay 2 Filter Type	Selects filter type used on Delay 2	LP1, LP2, L2R, BP, BPR, NCH, HP1, HP2
24 FP	44	Delay 2 Filter Frequency	Frequency of filter from #23	46 Hz - 21.0 kHz
25 FP	45	Delay 2 Filter Q	Q of Filter 2	.70 - 107
26	46	Delay 2 Feedback Signal Source	Determines route of signal returned to Delay 2	dir (direct), flt (filter), dif (diffusion)
27	47	Delay 2 Wet Signal	Determines route of wet signal out of Delay 2	dir (direct), flt (filter), dif (diffusion)
28	48	Delay 2 Wet Pan	Destination of wet signal from Delay 2 to outputs	Ch1 thru 0 to Ch2
29	49	Delay 2 Wet Attenuation	Delay 2 wet volume	0db - Off
30 - 35 FP	50-55	Source for Modulation Modules 1 thru 6	Modulation sources (oscillators), midi controllers	tri1/saw1, tri2/saw2, tri3, tri4, ran1, ran2, log, mod, breath, foot, vol, bal, pan, kbd lo, kbd hi

Parameter <i>FP= front panel knob</i>	MIDI Ctrl#	Title	Description	Control Range
36 - 41 FP	56-61	Destination for Modulation Modules 1 thru 6	Sets parameter the modulation sources will affect	Off, dL1, F1F, di1, Fb1, In1, IL1, do1 dA1. dL2, F2F, di2 Fb2, In2, IL2, do2, dA2, OTL
42 - 47 FP	62-67	Level for Modulation Modules 1 thru 6	Determines depth of Modules 1-6	-1.0 - 0 - 1.0
48 FP	68	Delay 1 Diffusion Amount	Blurs signal repeats	Off - 16
49 FP	69	Delay 2 Diffusion Amount	Blurs signal repeats	Off - 16
50 - 53 FP	70-73	Osc. Frequency	Sets modulation rates for Oscillators tri1/saw1, tri2/saw2, tri3, tri4	.031 - 48.9Hz
54	74	Random 1 Rate	Rate of change for Random Modulator 1	.031 - 48.9Hz
55	75	Random 1 Smoothing	Averages changes in Random Modulator 1	10ms - 1.8 Sec
56	76	Random 2 Rate	Rate of change for Random Modulator 2	.031 - 48.9Hz
57	77	Random 2 Smoothing	Averages changes in Random Modulator 2	10ms - 1.8 Sec
58	78	Log Converter Source	Signal Source for Log Converter	IN1, IN2, DL1, DL2, OT1, OT2
59	79	Log Smoothing	Averages log changes	10ms - 1.80 Sec
60 FP	80	Room Size	Sets size of room for early reflection programs	Sm1, Sm2, Sm3, Sm4, Med1, Med2, Med4, Lg1, Lg2, Lg3, Lg4, HL1, HL2, HL3, HL4
61	81	Early Reflection Tap Attenuation	Volume of reflections	0db - Off
62	82	Signal Source L/R	Pans signal source across room left to right	L - 0 - R
63	83	Signal Source F/R	Pans signal source front to rear of room	F - 0 - R
64	84	Listener Location L/R	Positions listener to sound source left to right	L - 0 - R
65	85	Listener Location F/R	Positions listener to sound source front to rear	F - 0 - R
66	86	Reflection coefficient	Reflectivity of walls	0 - 1.0
67	87	Ear Width	Distance between Ch1 & Ch2 receivers	0.0 - 10.0 (meters)
68	88	External Tap Switch Option	Sets delay(s) the tap footswitch will affect	Off, Delay 1, Delay 2, Delay 1 & 2, Delay 1 & 2 proportional, Delay 2 & 1 proportional
69	89	Memory Width	Sets resolution of memory or enables Room Simulation	16-bit, 24-bit, ERL
70 FP	90	MIDI Clock 1	Divides echo to match MIDI bpm input for Delay 1	Off, 4b, 3b, 2b, 1b, 2, 2.3, 4, 4.3, 8, 8.3
71 FP	91	MIDI Clock 2	Divides echo to match MIDI bpm input for Delay 2	Off, 4b, 3b, 2b, 1b, 2, 2.3, 4, 4.3, 8, 8.3
72	92	MIDI Clock Divide	Determines MIDI resolution to follow	24, 48, 96
73 FP	93	Diffusion Model Delay 1	Sets size model for diffusion in Delay 1	Sm1, Sm2, Med1, Med2, Lg1, Lg2
74 FP	94	Diffusion Model Delay 2	Sets size model for diffusion in Delay 2	Sm1, Sm2, Med1, Med2, Lg1, Lg2
75	95	Name 0	Lettering for preset name - 1st character	variety of characters
76	96	Name 1	2nd character	variety of characters
77	97	Name 2	3rd character	variety of characters
78	N/A	MIDI Channel	Sets MIDI channel to which 606 will respond	1 - 16, All
79	N/A	MIDI Unit	Determines MIDI unit to which 606 will respond	0 - 126, All
80	N/A	Memory Protect	Forbids overwriting of program	Prt On - Off

PRESET LOCATIONS AND NAMES

These presets exemplify most of the types of programs one might want to construct in the 606. Read the descriptions until you find the preset that describes your application. Press LOAD to activate that preset. Make changes or modifications. When you are ready to save the new preset, turn the PRESET knob to the desired number location. The preset number will be flashing to show that it has not been saved. Press and hold the SAVE button. The preset number will stop flashing to show that the program was saved. You cannot erase the upper 10 Building Block presets, so you can always refer to them when you want to make new programs.

Mixed Bag

These first 9 presets are various examples of what the 606 can do. These presets exist in locations 100 - 109, and so these should be the first to replace when making your own programs. Remember that you can name the presets using Parameters 75, 76, and 77.

- | | | | |
|----|----|-----|--|
| 1. | P1 | 2CH | Dual Mono Program - same as preset 100 |
| 2. | P2 | 1CH | 1 Channel Program - same as preset 101 |
| 3. | P3 | Ste | Stereo Program - same as preset 102 |
| 4. | P4 | 1-2 | Single Input Stereo Program - same as preset 103 |
| 5. | P5 | Flg | Flanger Program - same as preset 104 |
| 6. | P6 | Chr | Chorus Program - same as preset 105 |
| 7. | P7 | Fbk | Coupled Feedback - same as preset 106 |
| 8. | P8 | Pan | Auto Panned Program - same as preset 107 |
| 9. | P9 | ERL | Room Simulation - same as preset 108 |

Dual Mono - 2 Channel Programs

- | | | | | |
|-----|-----|---------------------|-----------|-----------|
| 10. | P10 | Double/Slap | D1-10 ms | D2-51 ms |
| 11. | P11 | Flam/Echo | D1-80 ms | D2-150 ms |
| 12. | P12 | Flager/Wah | D1-.83 ms | D2-22 ms |
| 13. | P13 | Flange2/Sprong | D1-1.7 ms | D2-54 ms |
| 14. | P14 | Flange3/Space | D1-.68 ms | D2-326 ms |
| 15. | P15 | Flange4/Wow | D1-.02 ms | D2-485 ms |
| 16. | P16 | Chorus1/Chorus2 | D1-21 ms | D2-.38 ms |
| 17. | P17 | Delay162/Delay380 | D1-162 ms | D2-380 ms |
| 18. | P18 | FakeVerb/Repeats | D1-11 ms | D2-120 ms |
| 19. | P19 | FakeVerb2/NegRepeat | D1-17 ms | D2-120 ms |

1 Channel Programs (Delay 1 output routed to Delay 2 input)

- | | | | | |
|-----|-----|---------------|-----------|-----------|
| 20. | P20 | Space Flange | D1-.68 ms | D2-329 ms |
| 21. | P21 | Bent | D1-.44 ms | D2-248 ms |
| 22. | P22 | Metal | D1-.42 ms | D2-528 ms |
| 23. | P23 | Dbl Delay | D1-250 ms | D2-375 ms |
| 24. | P24 | Echo Flange | D1-414 ms | D2-2.1 ms |
| 25. | P25 | Echo Flange 2 | D1-290 ms | D2-.61 ms |
| 26. | P26 | Echo Flange 3 | D1-290 ms | D2-1.5 ms |
| 27. | P27 | Rhythm | D1-98 ms | D2-269 ms |
| 28. | P28 | Slappy | D1-295 ms | D2-82 ms |
| 29. | P29 | Drill | D1-124 ms | D2-4.0 ms |

Stereo Programs

- | | | | | |
|-----|-----|----------|-----------|-----------|
| 30. | P30 | Shimmers | D1-192 ms | D2-197 ms |
|-----|-----|----------|-----------|-----------|

606
Delay F/x
Machine

31.	P31	Metal Closet	D1-66 ms	D2-76 ms
32.	P32	Stereo Chorus	D1-25 ms	D2-36 ms
33.	P33	Sustained Echo	D1-149 ms	D2-139 ms
34.	P34	Diffused Echo	D1-277 ms	D2-337 ms
35.	P35	Intimate Echo	D1-277 ms	D2-337 ms
36.	P36	Tremolo	D1-280 ms	D2-421 ms
37.	P37	Short Tap	D1-72 ms	D2-76 ms
38.	P38	Strange	D1-.02 ms	D2-486 ms
39.	P39	Cycle	D1-10 ms	D2-89 ms

Flangers

40.	P40	Dual Flangers	D1-.02 ms	D2-.02 ms
41.	P41	Stereo Flanger	D1-.29 ms	D2-.27 ms
42.	P42	Light Flange	D1-2.0 ms	D2-1.6 ms
43.	P43	Drunk	D1-6.3 ms	D2-7.4 ms
44.	P44	Long Flange	D1-.21 ms	D2-.23 ms
45.	P45	Phase & Flange	D1-.21 ms	D2-.23 ms
46.	P46	1CH Flange	D1-.21 ms	D2-.23 ms
47.	P47	1CH Flange2	D1-.02 ms	D2-3.8 ms
48.	P48	Bounce	D1-.02 ms	D2-485 ms
49.	P49	For Strings	D1-.21 ms	D2-.23 ms

1-2 Programs: Single Feed Stereo Programs

50.	P50	Lazy Delay	D1-233 ms	D2-253 ms
51.	P51	Split	D1-280 ms	D2-420 ms
52.	P52	End of the Night	D1-71 ms	D2-75 ms
53.	P53	High Hat Slap	D1-33 ms	D2-56 ms
54.	P54	Shuffle	D1-63 ms	D2-67 ms
55.	P55	Stereo Double	D1-44 ms	D2-45 ms
56.	P56	Metallic Double	D1-17 ms	D2-19 ms
57.	P57	Follow Along	D1-17 ms	D2-365 ms
58.	P58	Wet Slap	D1-67 ms	D2-65 ms
59.	P59	Wet Echo	D1-119 ms	D2-117 ms
60.	P60	Squirm		70. P70 Backward
61.	P61	Aliens		71. P71 You too?
62.	P62	Cascades		72. P72 Dreamscape
63.	P63	Movie Dreams		73. P73 Shimmer Box
64.	P64	Rich Echos		74. P74 Cats
65.	P65	Practice Room		75. P75 Spacey
66.	P66	Concrete Walls		76. P76 Trip
67.	P67	3-D Swirls		77. P77 Env Flange
68.	P68	Hangover		78. P78 Swirling
69.	P69	Bad Scene		79. P79 Best Seat in the House

ERL - Room Simulations

80.	P80	Med Wet Room
81.	P81	Source Right/Front
82.	P82	Source Left/Back

Delay F/x Machine 606

-
- 83. P83 Sitting on the Piano
 - 84. P84 Wide StereoView
 - 85. P85 Left of Room Small
 - 86. P86 Tile Room
 - 87. P87 Snare Room
 - 88. P88 Modulated Room
 - 89. P89 Swept Room

Reverb Simulations

- 90. P90 Wet Booth
- 91. P91 Tight Plate
- 92. P92 Water Closet
- 93. P93 Off Center Plate
- 94. P94 Shallow Room
- 95. P95 Tuned Room
- 96. P96 Drum Closet
- 97. P97 Close Walls
- 98. P98 Battlefield
- 99. P99 Warehouse

BUILDING BLOCK ROM PRESETS

Location 100 - 2Ch - 2 Channel Program (Dual Mono) - Lets the two delay channels act independently (like two separate units). Tap input (Parameter 68) is enabled if a footpedal is inserted. The tap tempo input is configured to affect Channels 1 and 2 proportionally.

Location 101 - 1Ch - 1 Channel Program - The output of Delay 1 is internally returned to the input of Delay 2 to allow one delay effect to run into the other delay effect. Tap input (Parameter 68) is enabled if a footpedal is inserted. The tap tempo input is configured to affect Channels 1 and 2 proportionally.

Location 102 - Ste - Stereo Program (Coupled) - The COUPLED LED comes on to show that there is some amount of signal being shared between the two delay channels. Pushing the MODE button will separate the two delay lines turning the program into DUAL MONO. The preset loaded here is sharing the two inputs between the delay channels.

Location 103 - 1-2 - Single Feed Stereo Program - The inputs are combined (you could use one input) to feed both delay lines with separate outputs. This is useful for making stereo effects from a single source.

Location 104 - Flg - Flanger - An example of modulated delays. Increase/decrease the delay time to change character. Change MODULATION amounts for depth or FEEDBACK for more smear. This program is a 1-2 type, with the modulator destination as the delay time.

Location 105 - Chr - Chorus - Another example of modulated delays. More modulators are used. This is a 1 - 2 style program with delay time also being modulated, but using two modulators pointed at the same destination.

Location 106 - Fbk - Stereo Feedback - This version of a COUPLED program uses the output of Delay 1 routed to the feedback of Delay 2 and visa-versa.

Location 107 - PAn - Stereo Outputs - The wet out from each delay channel is modulated (auto-panned) between the two outputs.

Location 108 - ERL - Room Simulation - Use this as a quick way of turning the 606 into a room simulator. The ROOM SIZE knob is used to choose rooms. Use Parameter 62 and 63 to position the signal source in the room. Use Parameter 64 and 65 to position the listener. Parameter 66 controls reflections and 67 controls listener ear width.

Location 109 - RVB - Reverb - Turns the 606 into a reverb processor. The MIX controls for each delay line should be set to 100% for this program. The ROOM SIZE control will set the reverb size and Parameter 66 will set the reflectivity.

Declaration of Conformity

We, **Symetrix Incorporated**, 14926 35th Ave West, Lynnwood, Washington, USA, declare under our sole responsibility that the product:

606 Delay F/x Machine

to which this declaration relates, is in conformity with the following standards:

EN 60065

Safety requirements for mains operated electronic and related apparatus for household and similar general use.

EN 50081-1

**Electromagnetic compatibility - Generic emission standard
Part 1: Residential, commercial, and light industry.**

EN 50082-1

**Electromagnetic compatibility - Generic immunity standard
Part 1: Residential, commercial, and light industry.**

The technical construction file is maintained at:

Symetrix, Inc.

14926 35th Ave. West
Lynnwood, WA, 98037-2303
USA

The authorized representative located within the European Community is:

World Marketing Associates
P.O. Box 34
Newquay, Cornwall, TR7 1TU, U.K.

Date of issue: 1 March 1997

Place of issue: Lynnwood, Washington, USA

Authorized signature:



Dane Butcher, President, **Symetrix Incorporated**.

**Delay F/x
Machine**

606

6006

Delay F/x Machine

 **Symetrix**



Symetrix, Inc.

14926 35th Ave. West
Lynnwood, WA, 98037-2303
USA

Tel: (425) 787-3222

Fax: (425) 787-3211

Website: <http://www.symetrixaudio.com>

Email: symetrix@symetrixaudio.com