

304 Headphone Amplifier

304



User's Guide

Table of Contents

<i>Chapter 1</i>	Introduction	1
<i>Chapter 2</i>	Operator Safety Summary	2
<i>Chapter 3</i>	Fast Setup	3
<i>Chapter 4</i>	Front & Rear Panel Overview	4
<i>Chapter 5</i>	Using the 304	5
<i>Chapter 6</i>	Applications	6
<i>Chapter 7</i>	Block Diagram	7
<i>Chapter 8</i>	Troubleshooting	8
<i>Chapter 9</i>	Specifications	9
<i>Chapter 10</i>	Warranty and Service	10
<i>Chapter 11</i>	Declaration of Conformity	13

Rev A, 31 October, 1998

Symetrix part number 53304-0A00

Subject to change without notice.

©1998, Symetrix, Inc. All right reserved.

Symetrix is a registered trademark of Symetrix, Inc.

Mention of third-party products is for informational purposes only and constitutes neither an endorsement nor a recommendation. Symetrix assumes no responsibility with regard to the performance or use of these products.

Under copyright laws, no part of this manual may be reproduced or transmitted in any form or by any means, electronic or mechanical, including photocopying, scanning, recording or by any information storage and retrieval system, without permission, in writing, from Symetrix, Inc.

 **Symetrix**

14926 35th Ave. West
Lynnwood, WA 98037 USA

Tel (425) 787-3222

Fax (425) 787-3211

Email: symetrix@symetrixaudio.com

304

 **Symetrix**

The Symetrix 304 Headphone Amplifier is a 1-in 4-out amplifier designed to drive multiple headphones of any impedance. Symetrix' proprietary high voltage drive technology gives the 304 the ability to drive high impedance headphones with the equivalent output *voltage* of a much larger power amplifier, yet provides more than ample *current* for low impedance phones. The four stereo outputs automatically adjust output power to match the load impedance.

Controls provided are input level, output level for each individual amplifier, and a stereo/mono switch.

The STEREO/MONO switch allows the amplifier to be used several ways. As a "normal" stereo amplifier (with four outputs), the left and right inputs are used for stereo signals, which feed the left and right outputs. Switching to mono with a stereo input provides a quick check of the mono compatibility of a stereo mix. For that matter, you may want to monitor in mono.

As a mono amplifier, one signal fed to either input will feed both outputs. Also in mono mode, when two *different* mono signals are fed to the left and right inputs, they will be mixed to feed both the left and right outputs.

The inputs are electronically balanced, but will operate normally in an unbalanced configuration when 2-conductor 1/4" plugs are inserted. The outputs are 1/4" stereo connectors.

Do you hate reading manuals? Chapter 3 of this manual was written just for you. Pleeeeeze! Skip the rest of this and just read Chapter 3. It will get you up and running with minimum reading and minimum pain. Try to read the rest of the manual later. It's worth it. Should you have any comments or questions, please do not hesitate to contact us. Your calls and e-mail are always welcome.

Phone: (425) 787-3222

Fax: (425) 787-3211

Email: symetrix@symetrixaudio.com

Website: www.symetrixaudio.com

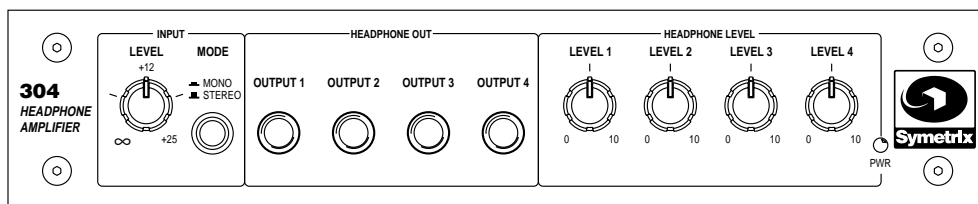

Front panel

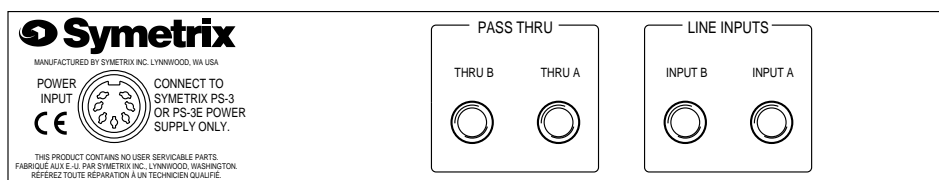

Rear panel

304

The information in this summary is intended for persons who operate the equipment as well as repair personnel. Specific warnings and cautions are found throughout this manual wherever they may apply.

The notational conventions used in this manual and on the equipment itself are described in the following paragraphs.

Equipment Markings



WARNING: TO REDUCE THE RISK OF FIRE OR ELECTRIC SHOCK DO NOT EXPOSE THIS EQUIPMENT TO RAIN OR MOISTURE

AVIS: RISQUE DE CHOC ELECTRIQUE NE PAS OUVRIR

SEE OWNERS MANUAL. VOIR CAHIER D'INSTRUCTIONS.
 No user serviceable parts inside. Refer servicing to qualified service personnel.
 Il ne se trouve a l'interieur aucune piece pouvant etre reparaee l'usager.
 S'adresser a un reparaateur competent.

The lightning flash with arrowhead symbol within an equilateral triangle is intended to alert the user of the presence of uninsulated “dangerous voltage” within the product's enclosure that may be of sufficient magnitude to constitute a risk of electric shock to persons.

The exclamation point within an equilateral triangle is intended to alert the user of the presence of important operating and maintenance (servicing) instructions in the literature accompanying the 304 (i.e. this manual).

Caution *To prevent electric shock, do not use the polarized plug supplied with the 304 with any extension cord, receptacle, or other outlet unless the blades can be fully inserted.*

Terms

Several notational conventions are used in this manual. Some paragraphs may use **Note**, **Caution**, or **Warning** as a heading. Certain typefaces and capitalization are used to identify certain words. These are:

Note Identifies information that needs extra emphasis. A **Note** generally supplies extra information to help you to better use the 304.

Caution Identifies information that, if not heeded, may cause damage to the 304 or other equipment in your system.

Warning Identifies information that, if ignored, may be hazardous to your health or that of others.

CAPITALS Controls, switches or other markings on the 304's chassis.

Boldface Strong emphasis.

Power source - This product is intended to operate from a power source that does not apply more than 255Vrms between the power supply conductors or between either power supply conductor and ground. A protective ground connection, by way of the grounding conductor in the power cord, is essential for safe operation.

Danger from loss of ground - If the protective ground connection is lost, all accessible conductive parts, including knobs and controls that may appear to be insulated, can render an electric shock.

In-line power supply - This product receives its operating power from the Symetrix PS-3 or PS-3E power supply. This is the only power supply approved for use with the product. Do not connect the product to any other in-line, or plug-in, transformer. The use of other power sources may cause damage to the equipment or present a shock hazard to the operator.

Operating location - Do not operate this equipment under any of the following conditions: explosive atmospheres, in wet locations, in inclement weather, improper or unknown AC mains voltage, or if improperly fused.

Stay out of the box - To avoid personal injury or injury to others, do not remove the product covers or panels. Do not operate the product without the covers and panels properly installed.

304

Fast First-Time Setup

This section is dedicated to users who hate to read manuals.

The 304 is a four-output headphone amplifier. A stereo input drives all four headphone amplifiers. Each amplifier has an independent level control. There is an overall master level control, and an overall STEREO/MONO switch.

Wiring

To install the 304:

- ① Plug the PS-3 power supply's DIN connector into the 304. Plug the PS-3 into a suitable source of AC power. Refer to the labelling on the PS-3 to determine what is suitable.
- ② Connect your source to the 304's tip-ring-sleeve input jacks. The inputs are balanced. They will work with either balanced or unbalanced sources.
- ③ Connect your headphones to the four output jacks. The 304 can handle headphone impedances ranging from 8-ohms to over 2000 ohms. 60-ohm headphones are optimal (they get the loudest). It is not necessary for each set of headphones to be the same (although it might help if they were).

Go!

Set the individual level controls to minimum (max ccw rotation). Set the master level control to the halfway position (12 noon). Set the stereo/mono switch as appropriate.

With the source signal active, adjust the individual level controls for comfortable listening levels.

Caution *The 304 is capable of driving many headphones past the threshold of pain. This can also result in hearing damage. For your own hearing health, monitor at the lowest SPL that you can use and still get the job done.*

304

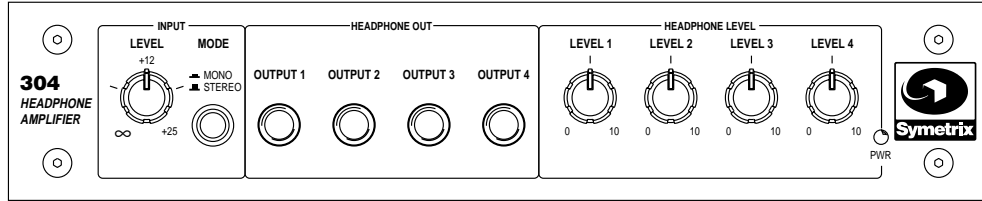

- INPUT LEVEL** Sets the input signal strength. Fully counterclockwise, no signal. Fully clockwise, input signals are boosted by 25 dB.
- MONO/STEREO** Combines stereo, or two mono, input signals into one mono output signal (fed equally to both left and right headphone outputs).
- HEADPHONE OUTPUTS** 1/4" stereo jacks for headphones. The minimum impedance is 8 ohms (see Table 1 for combined headphone impedances).
- HEADPHONE LEVELS** Volume controls set the signal strength at the corresponding output jack (1-4).
- PWR** Red LED indicates power “on”.

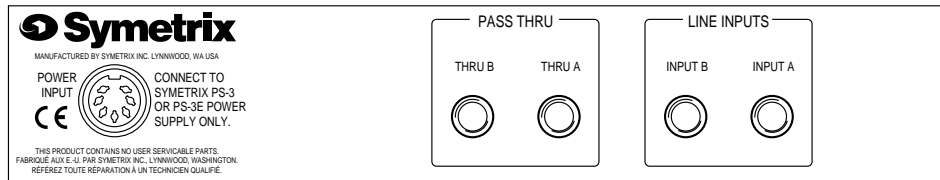

- 7-PIN DIN CONNECTOR** Connect the 7-pin DIN plug end of a Symmetrix PS-3 (117V) or PS-3E (230V) here. Connect the AC power connector end of the PS-3 or PS-3E to an AC power source that is of the correct voltage and frequency as marked on the PS-3 or PS-3E.
- THRU A** TRS jack connected in parallel with INPUT A jack. Use this jack to connect to other 304's or other audio equipment. It's a built-in wye cord.
- THRU B** TRS jack connected in parallel with INPUT B jack. Use this jack to connect to other 304's or other audio equipment. It's a built-in wye cord.
- INPUT A (Left channel)** 3 conductor 1/4" jack for line level balanced or unbalanced input signals. Tip = high (+), Ring = low (-), Sleeve = ground.
- INPUT B (Right channel)** 3 conductor 1/4" jack for line level balanced or unbalanced input signals. Tip = high (+), Ring = low (-), Sleeve = ground.

304

Impedance, Sensitivity, Loudness

Loudness is directly related to the impedance and sensitivity of the headphones. Impedance determines how much power the headphones will draw, while sensitivity indicates how much of the electrical signal delivered to the headphones is converted into sound.

Because low impedance headphones draw more power from the amplifier they will sound louder, at the same control settings, than high impedance headphones. Also, headphones of higher sensitivity will sound louder than those of lower sensitivity. Check the manufacturer's spec sheet for impedance and sensitivity information.

Proprietary high voltage driver technology allows the 304 to drive even high impedance headphones to maximum levels, because the amplifiers are capable of very high output voltage swing. However, to get a loudness equivalent to that of low impedance headphones, the controls will have to be set to higher settings when using high impedance headphones. This is normal.

If low and high impedance headphones are combined on the same channel, the low impedance headphones will be much louder. As a result, when a combination of high impedance and low impedance headphones is used, only those of like impedance should be used on the same channel. This allows each listener to properly adjust loudness, without regard to the impedance and sensitivity of the other headphones. (It's ok to mix impedances on the same amplifier, it's just not optimum. You won't hurt anything.)

Maximum Amplifier Load

The minimum operating impedance, or maximum load, for each output of the 304 is 8 ohms. Use as many pairs of headphones as desired, as long as the total combined impedance (per output) does not fall below 8 ohms. Table 1 shows how many headphones of various impedances may be used with *each* output of the 304.

Table 1 - Combined Impedance Values (approx. 8:)

Impedance of Headphones	Maximum Number/Channel
8 (see note 1)	1
16	2
32	4
100	10
200	20
400	40
600	60

Note 1: The quantities given above reflect usage with typical wide-range musical signals. If you are driving low-impedance headphones (16-ohms or lower *actual* impedance), and you intend to drive them to the brink of amplifier clipping, then you should revise the number of headphones possible (per 304) to 2 8-ohm headphones or 4 16-ohm headphones (for the 8-ohm case, you'll have two amplifier channels that aren't doing anything). It is OK to use any remaining amplifier channels with higher impedance phones (50 ohms or higher).

For maximum output with all channels driven, try to restrict the lowest combined load impedance to 50 ohms per channel. Lower impedance loads simply reduce the maximum output possible.

Note 2: Many headphones are spec'd as being suitable for eight-ohm outputs. They are, but this does not mean that their actual impedance is 8-ohms. In most cases, the actual impedance is substantially higher. This is good (rather than bad). For whatever it's worth, most decent headphones have actual impedances ranging from 50 ohms and up.

Note 3. When multiple headphones are required with each output, use headphone type "Y" cords, or a "breakout box." A breakout box may have as many paralleled 1/4" stereo jacks as necessary, as long as the numbers in Table 1 are not exceeded.

304

The 304 can be used in the following applications. Please note that this list is far from comprehensive and your imagination may create new uses that we haven't listed here.

PROJECT STUDIO Let the 304 expand your mixer's headphone capacity. You can drive it via a tip-ring-sleeve to dual tip-sleeve cable from your mixer's headphone jack, or from one or two of your mixer's aux sends. If you only use one aux send, then press the stereo/mono switch to route the signal to both channels.

BROADCAST Use the 304 to drive the guest headphones in your studio.
Does your console have an anemic headphone amplifier? The 304 will make it roar.

LIVE SOUND Does your console have an anemic headphone amplifier? The 304 will make it roar.

HOUSE OF WORSHIP Create assistive listening stations at several pews. Drive the 304 with a mixture of the sound reinforcement signal and a room microphone.
No, this isn't as sophisticated as one of the RF or infrared systems, but it doesn't cost like they do either!

BALANCED LINE DRIVER Here's how to use the 304 as a one-in, four out balanced line amplifier. Make a wye cable so that you can drive both inputs in parallel. Wire the plug for the right-channel input so that it is reverse polarity from the left-channel input.

Connect your source to the wye-cable's input.

Connect each of your balanced loads to the tip-ring-sleeve output connectors. The tip connection is hot.

304

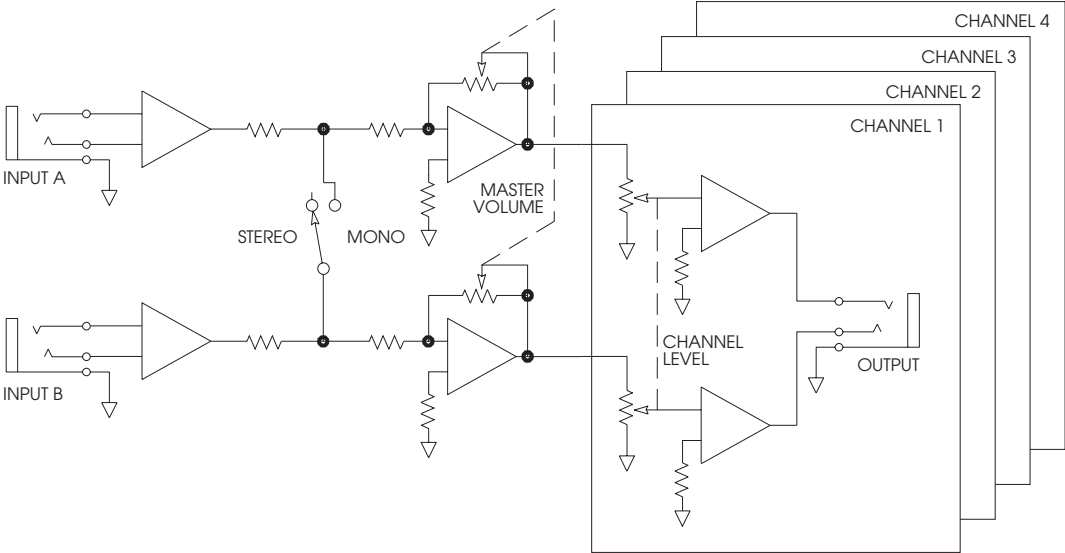

304

Troubleshooting Chart

<u>SYMPTOM</u>	<u>PROBABLE CAUSE</u>
No output	Check cables and connections. Are inputs driven by outputs, and outputs driving inputs? Verify cables, source and load. Check for AC power presence.
Hum or buzz in output	Check input and output connector wiring. Ground loop: check related system equipment grounding. Are all system components on the same AC ground?
Distortion	Check input signal. Is it too hot, or is it already distorted? Check the output loading. Is something else clipping?
Noise (hiss)	Check input signal levels. The 304 is intended to operate at or near “line” level (+4dBu is nominal). Make sure that the signal you are feeding to the 304 is a line level signal, not mic level. Make sure that all systems components are on the same AC ground. Check gain settings on upstream equipment. The system gain structure should be such that the 304 receives +4dBu nominal signal. Is the input signal already noisy?
No LED display	Is the unit plugged in? Is the AC outlet OK?

304

Architects and Engineers Specifications

The headphone amplifier shall have a single stereo input and four stereo outputs. Each output shall have its own amplifier and volume control. An overall volume control (master) shall also be provided. There shall be an overall stereo/mono switch.

All inputs are balanced bridging inputs. Outputs shall be suitable for driving headphones in the range of 8 ohms to 2000 ohms. The output source impedance shall be 100 ohms.

The headphone amplifier shall be capable of delivering 35 volts peak-to-peak into a 2000 ohm load (or greater).

The unit shall be capable of operating by means of a Symetrix PS-3 or PS-3E external power supply connected to 117V nominal AC (95 to 130V), 50/60 Hz or 230V nominal AC, 207 to 253V AC, 50 Hz where applicable.

The unit shall be a Symetrix, Inc. model 304 Headphone Amplifier.

Specifications

Input/Output

Input Type	Bridging, Balanced or Unbalanced
Maximum Input Level	+18dBu Balanced
Maximum Output Level	21dBm, 600 Ohm load, >6VRMS, 200 Ohm load
Input Impedance	20k Ohms Balanced, 10k Ohms Unbalanced
Output Impedance	100 Ohms

Performance Data

Frequency Response	20Hz to 20kHz, +0, -1 dB
THD+Noise	.01% (1kHz, 0dBm, 600 Ohms) .02% (1kHz, +20dBm, 600 Ohms)
Signal-to-Noise Ratio	95dB
Maximum Gain	25dB

Connections

Input	1/4" in. TRS
Output	1/4" in. TRS
Power In	7 pin DIN

Physical

Size (hwd)	1/2 rack unit 1.75 x 8.5 x 6.5 in., 4.445 x 21.59 x 15.875 cm.
Shipping Weight	4.5 lbs

Electrical

Power Requirements	117V nominal, 95 to 130V AC, 50 to 60 Hz 230V nominal, 207 to 253V AC, 50 Hz
--------------------	---

In the interest of continuous product improvement, Symetrix, Inc. reserves the right to alter, change, or modify these specifications without prior notice.

©1998, Symetrix, Inc. All rights reserved.

304

304 Limited Warranty

Symetrix, Inc. expressly warrants that the product will be free from defects in material and workmanship for one (1) year. Symetrix's obligations under this warranty will be limited to repairing or replacing, at Symetrix's option, the part or parts of the product which prove defective in material or workmanship within one (1) year from date of purchase, provided that the Buyer gives Symetrix prompt notice of any defect or failure and satisfactory proof thereof. Products may be returned by Buyer only after a Return Authorization number (RA) has been obtained from Symetrix. Buyer will prepay all freight charges to return the product to the Symetrix factory. Symetrix reserves the right to inspect any products which may be the subject of any warranty claim before repair or replacement is carried out. Symetrix may, at its option, require proof of the original date of purchase (dated copy of original retail dealer's invoice). Final determination of warranty coverage lies solely with Symetrix. Products repaired under warranty will be returned freight prepaid by Symetrix via United Parcel Service (surface), to any location within the Continental United States. At Buyer's request the shipment may be returned via airfreight at Buyer's expense. Outside the Continental United States, products will be returned freight collect.

The foregoing warranties are in lieu of all other warranties, whether oral, written, express, implied or statutory. Symetrix,

Inc. expressly disclaims any IMPLIED warranties, including fitness for a particular purpose or merchantability. Symetrix's warranty obligation and buyer's remedies hereunder are SOLELY and exclusively as stated herein.

This Symetrix product is designed and manufactured for use in professional and studio audio systems and is not intended for other usage. With respect to products purchased by consumers for personal, family, or household use, Symetrix **expressly disclaims all implied warranties, including but not limited to warranties of merchantability and fitness for a particular purpose.**

This limited warranty, with all terms, conditions and disclaimers set forth herein, shall extend to the original purchaser and anyone who purchases the product within the specified warranty period.

Warranty Registration must be completed and mailed to Symetrix within thirty (30) days of the date of purchase.

Symetrix does not authorize any third party, including any dealer or sales representative, to assume any liability or make any additional warranties or representation regarding this product information on behalf of Symetrix.

This limited warranty gives the buyer certain rights. You may have additional rights provided by applicable law.

Limitation of Liability

The total liability of Symetrix on any claim, whether in contract, tort (including negligence) or otherwise arising out of, connected with, or resulting from the manufacture, sale, delivery, resale, repair, replacement or use of any product will not exceed the price allocable to the product or any part thereof which gives rise to the claim. In no event will Symetrix be liable for any incidental or

consequential damages including but not limited to damage for loss of revenue, cost of capital, claims of customers for service interruptions or failure to supply, and costs and expenses incurred in connection with labor, overhead, transportation, installation or removal of products or substitute facilities or supply houses.

304

Servicing the 304

If you have determined that your 304 requires repair services and you live *outside* of the United States, please contact your local Symetrix dealer or distributor for instructions on how to obtain service. If you reside in the U.S. then proceed as follows:

Before sending anything to Symetrix, contact our Customer Service Department for a return authorization (RA) number. The telephone number is (425) 787-3222, Monday through Friday, 8AM (0800 hours) though 4:30 PM (1630 hours) Pacific Time.

At the Symetrix factory, Symetrix will perform in-warranty or out-of-warranty service on any product it has manufactured for a period of five years from date of manufacture.

In-warranty Repairs

To get your 304 repaired under the terms of the warranty:

1. Call us for an RA number.
2. Pack the unit in its original packaging materials.
3. Include your name, address, daytime telephone number, and a brief statement of the problem.
4. Write the RA number on the outside of the box.
5. Ship the unit to Symetrix, freight prepaid.

We do *not* accept freight collect shipments.

Repairs made in-warranty will cost you only one-way freight charges. We'll prepay the return (surface) freight.

If you send us your product in substandard packaging, we will charge you for factory shipping materials. If you don't have the factory packaging materials, please use an oversized carton, wrap the unit in a plastic bag, and surround it with bubble-wrap. Pack the box full of Styrofoam peanuts. Be sure there is enough clearance in the carton to protect the rack ears (you wouldn't believe how many units are returned with bent ears). We will return the unit in Symetrix packaging. Of course, if the repair is due to operator error, parts and labor will be charged. In any event, if there are charges for the repair costs, you will pay for the return freight. All charges will be COD unless you have made other arrangements (prepaid, Visa or Mastercard).

Out-of-warranty Repairs

If the warranty period has passed, you'll be billed for all necessary parts, labor, packaging materials, and freight charges. Please remember, you must call for an RA number before sending the unit to Symetrix.

304

 **Symetrix**

304

 **Symetrix**

Declaration of Conformity

We, **Symetrix Incorporated**,
14926 35th Ave. West, Lynnwood, Washington, USA,
declare under our sole responsibility that the product:

304 Headphone Amplifier

to which this declaration relates,
is in conformity with the following standards:

EN 60065
Safety requirements for mains operated electronic and related apparatus for household and similar general use.

EN 50081-1
Electromagnetic compatibility - Generic emission standard
Part 1: Residential, commercial, and light industry.

EN 50082-1
Electromagnetic compatibility - Generic immunity standard
Part 1: Residential, commercial, and light industry.

The technical construction file is maintained at:

Symetrix, Inc.
14926 35th Ave. West
Lynnwood, WA, 98037-2303
USA

The authorized representative located within the European Community is:

World Marketing Associates
P.O. Box 100
St. Austell, Cornwall, PL26 6YU, U.K.

Date of issue: October 31, 1998
Place of issue: Lynnwood, Washington, USA

Authorized signature:



Dane Butcher, President, **Symetrix Incorporated**.

304

304

 **Symetrix**



Symetrix, Inc.

14926 35th Ave. West
Lynnwood, WA, 98037-2303
USA

Tel: (425) 787-3222

Fax: (425) 787-3211

Website: <http://www.symetrixaudio.com>

Email: symetrix@symetrixaudio.com