

Quick Start

Realizing that in most areas there are laws against reading owners manuals, and that reading them under the blankets at night with a flashlight makes you feel stupid, we therefore provide this brief, yet legal description of how to use the SM 26S just in case your batteries are low and your mother is about to come in the room.

To achieve a quick understanding of the SM 26S, think of it as a six channel mixer with faders and pans only. Or think of it as a 2-to-6 channel splitter with output level controls and a mix knob (to control how much of which input goes to which output). If you get that, you may stop here as long as you know what a TRS plug is.

As a six channel mixer, **MONO INPUT 1** through **6** may be placed on the Right or Left bus or both, in any amount. The respective **LEVEL** controls on the front serve as the mixer's faders, the adjacent **PAN** controls place the channel's signal into the stereo field. As an effects mixer or line level expander for a larger mixer, set up the **LEVELS** then adjust the **PANS**. The **MASTER OUTPUT LEVEL** adjusts the overall level of the mix at the Master Outputs.

As a splitter, place one or both input signals into the **LEFT** and/or **RIGHT MASTER INs**. Select the Input(s) to be placed at each of the six **MONO OUTPUTS** by rotating the **MIX / PAN** control to the proper position. Set the individual channel **LEVEL** controls for proper output level. The **MASTER INPUT LEVEL** control adjusts both Right and Left Input signal levels together.

SM 26S Connection

When connecting the SM 26S to other components in your system for the first time, *leave the power cord for last*. This gives you a chance to make mistakes and correct them before damage is done to anything fragile.

As you have no doubt noticed, all Inputs and Outputs on the SM 26S's rear panel are 1/4" connectors. The Inputs and Outputs are active balanced on Tip-Ring-Sleeve (TRS) jacks which allow the flexibility of connecting in either a balanced or unbalanced fashion. If unbalanced operation is your preference, the simplest way to accomplish this is through the use of tip-sleeve 1/4" connectors. The ring is not essential unless balanced operation is required. Be aware that if you are running unbalanced and using TRS connectors with both tip and ring, the ring and sleeve must be shorted together. Failure to do so on the inputs results in a gain loss of 6 dB.

Balanced operation requires that TRS plugs be used. The tip is hot (+), the ring is return (-) and the sleeve is ground. Rane-Note, "Sound System Interconnection" (included here) contains some great pictures to aid your interconnect ventures.

Front Panel Description

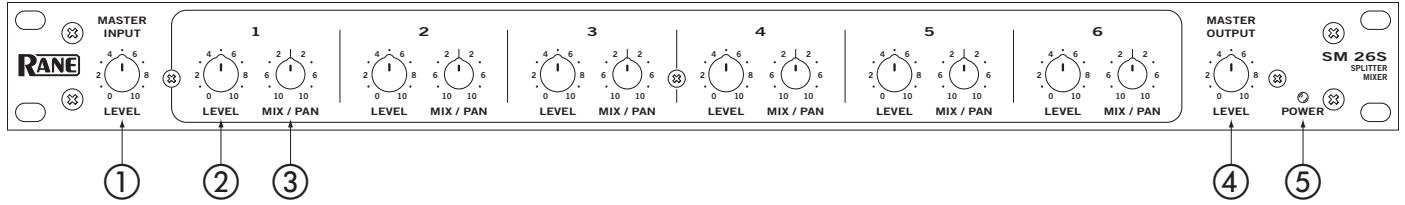

- ① **MASTER INPUT LEVEL** sets the gain of the Left & Right Master Input stages, with a range of Off to +12 dB. In the splitting mode, this controls the Level of all Mono channel Outputs at once (i.e., those which do not have a separate input).
- ② **Mono Input LEVEL** controls the Level of signal through each particular channel. When fed from the MONO INPUT jack, each stage has a gain range from Off to +12 dB minimum, allowing level matching of -10 dBV equipment to +4 dBu gear. When fed via the LEFT & RIGHT MASTER IN, these LEVEL controls automatically limit to a maximum of unity gain to accommodate the +12 dB available from the Left & Right Input gain stages.
- ③ **MIX / PAN** serves two different functions:
 - MIX:** When used as a SPLITTER, this controls the mix of Left and Right Master Input program to each channel's MONO OUT.
 - PAN:** When used as a MIXER, this control pans the Mono channel Input between the LEFT and RIGHT MIX OUTPUTS.
- ④ **MASTER OUTPUT LEVEL** controls the gain of the output stages and the amount of signal at the MIX OUTPUT jacks. It does not affect the level of any of the six MONO OUTPUTS. This allows an increase in headroom to eliminate overloading due to excessive combined signal from one or more Inputs. Range of gain is from Off to 0 dB (unity). Refer to the block diagram below.
- ⑤ **POWER indicator:** When this yellow LED is *lit*, the SM 26S is ready to go (when it's off, it's not).

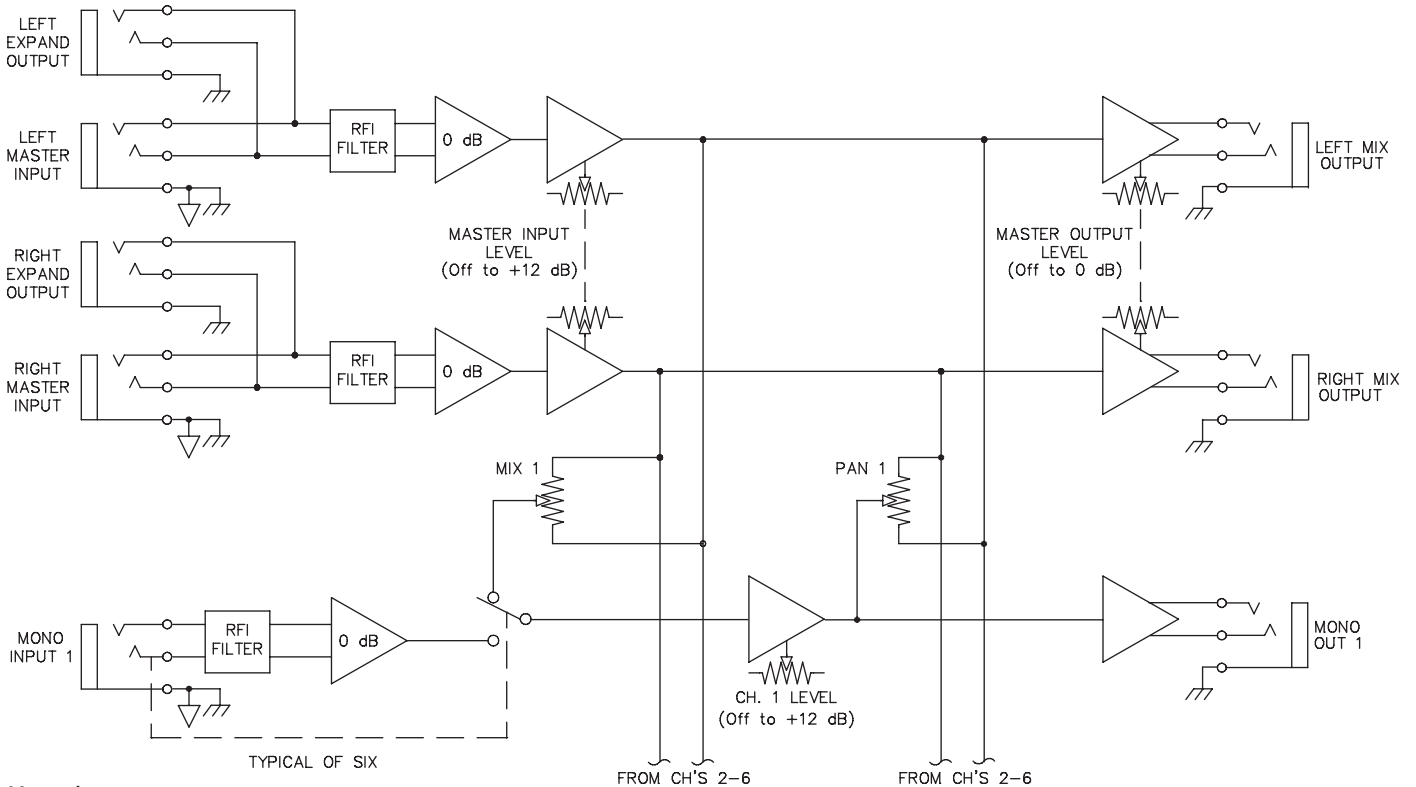

Rear Panel Description

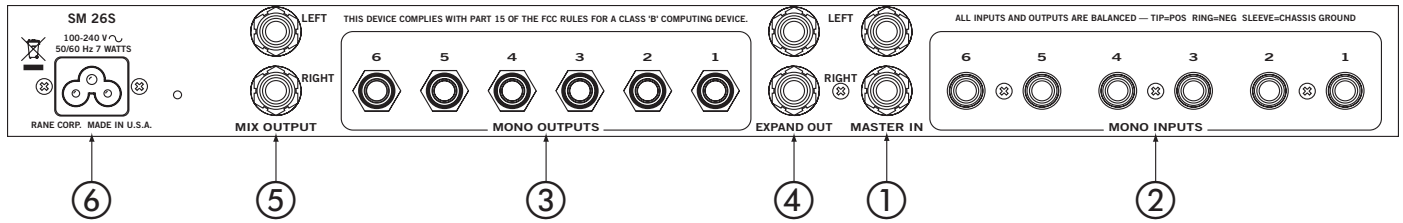

- ① **MASTER IN** are balanced Tip-Ring-Sleeve (TRS) ¼" Master Inputs. These Inputs feed all six MONO OUTs when all MONO INs are not used. Connecting to individual MONO INs disconnects that channel from these Inputs (refer to the Block Diagram). For unbalanced operation use a standard mono ¼" plug; for balanced operation use a TRS (stereo) ¼" plug wired as follows:
TIP is signal + (connect to Pin 2 on a 3-pin connector).
RING is signal - (pin 3 in a 3-pin connector).
SLEEVE is chassis ground.
- ② **MONO INPUTS** are TRS ¼" jacks which accept either balanced or unbalanced mono signals. These are switching jacks which automatically bypass the MASTER IN jacks whenever a plug is inserted (see the Block Diagram). Same wiring conventions as ①.
- ③ **MONO OUTPUTS** are ¼" TRS jacks that deliver either an unbalanced output (use TS plugs), or a balanced output (use TRS plugs). Follow wiring conventions as in ①.
- ④ **EXPAND OUTS** are ¼" TRS jacks connected in parallel with the MASTER IN jacks, allowing two or more SM 26Ss to be daisychained for multiple splitting. Simply connect the EXPAND OUT to the MASTER IN of another SM 26S; there is no limit to the number of expansions possible with the SM 26S.

NOTE: These Expand Outputs are *not* buffered from the Master Inputs. Therefore it is not possible to mix both balanced and unbalanced lines in the same channel between several units: once the ring and sleeve are shorted anywhere in the chain (by using a mono plug) the entire line becomes unbalanced.
- ⑤ **MIX OUTPUTS** are balanced TRS ¼" outputs controlled by the MASTER OUTPUT LEVEL control. They are fed either by the MASTER IN or by any of the six MONO INPUTS, or a combination of both (see *The Swiss Army Mixer* RaneNote). Follow wiring conventions as in ①.
- ⑥ **Universal Voltage Input:** via a miniature IEC 60320 C6 appliance inlet. This mates with an IEC 60320 C5 line cord (USA domestic). Do **not** lift the ground connection!

Operating Instructions

Since numerous applications exist for the SM 26S, no single set of operational procedures control its use. *The SM 26S Swiss Army Mixer* RaneNote (included) explores the many configurations of the SM 26S in depth, and you should peruse it for applications information.

Internal Jumper Options

There exist within the SM 26S some signal routing options, requiring removal of the top cover to move some jumpers. This must only be done with the power off by qualified service personnel.

If an SM 26S needs to have an additional set of independent outputs, as in a 2x4 stereo distribution amplifier (see *Swiss Army Mixer*, Figure 10), the LEFT and RIGHT MIX OUTPUTS can be used in addition to the 6 MONO OUTS. Normally, the LEFT and RIGHT MIX OUTPUTS produce the sum mix of all 6 LEVEL and PAN controls. To break any channel away from the Mix Output bus, internal jumpers have been provided. These are located behind the MIX/PAN controls for each channel. J3 connects MONO OUT 1 to the mix bus. J6 connects MONO OUT 2, J9 connects MONO OUT 3, and so on — see the board layout.

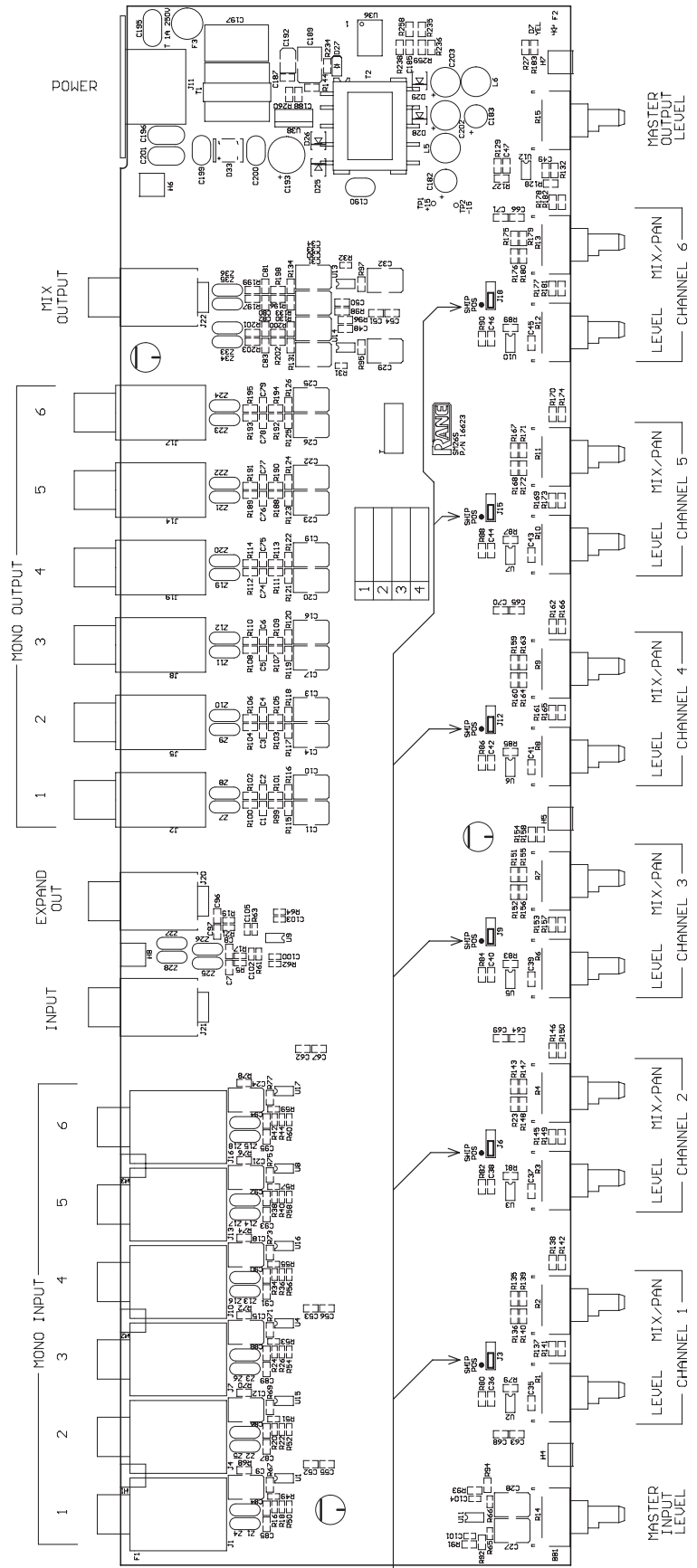

SHIP POSITION: SEND CHANNEL OUTPUT TO THE MIX BUS
CHANGE JUMPER TO DISCONNECT AND ONLY ROUTE TO THE MONO OUT