

OPERATION AND MAINTENANCE MANUAL

STEREO SYNTHESIZER

MODEL 245E

orban

ORBAN ASSOCIATES INC.

645 BRYANT STREET

SAN FRANCISCO, CA 94107

[415] 957-1067

TABLE OF CONTENTS

INTRODUCTION	1
DESCRIPTION	1
INSTALLATION - MECHANICAL	1
INSTALLATION - ELECTRICAL	1
General	1
Power	1
Input	2
Output	2
Grounding	2
OPERATING INSTRUCTIONS	2
PERFORMANCE TEST	3
MAINTENANCE	3
Preventive Maintenance	3
Factory Service	4
Replacement of Components on Printed-Circuit Boards	4
Troubleshooting IC Opamps	4
SHIPPING INSTRUCTIONS	4
CIRCUIT DESCRIPTION (WITH TROUBLESHOOTING HINTS)	5
Signal Processing Circuitry	5
Power Supply	6
APPENDIX A - SPECIFIC APPLICATIONS	7
Recording Studios	7
Broadcasting	7
Projection Television	7
APPENDIX B - SPECIFICATIONS	7
APPENDIX C - PARTS LIST	8
ASSEMBLY DRAWING	9
SCHEMATIC	11



REGISTRATION CARD

The original purchaser should have received a postpaid Registration Card packed with this manual.

Registration is of benefit to you because it enables us to tell you of new applications, possible performance improvements, service aids, etc., which may be developed over the life of the product. It also provides us with the date of sale so that we may more promptly respond to possible claims under Warranty in the future (without having to request a copy of your Bill of Sale or other proof of purchase).

Please fill in the Registration Card and return it to us.

If the Registration Card has become lost or you have purchased the unit used, please photocopy the image of the card reproduced below and send it to us in an envelope. Use the address shown on the title page.

Model # _____	Serial # _____
Name or Title _____	
Organization _____	
Street _____	
City/State/Country _____	
Zip or Mail Code _____	
Purchased from _____	City _____ Date of Purchase _____
Nature of your application _____	
How did you hear about it? _____	
Comments: _____	

Fig. 1: REGISTRATION CARD

WARRANTY

The Warranty, which applies only to the first end-user of record, is stated on the Warranty Certificate on a separate sheet packed with this manual. Save it for future reference.

Details on obtaining factory service are provided in **Part C**.

STEREO SYNTHESIZER

MODEL 245E

INTRODUCTION

You are now the owner of a model 245E Stereo Synthesizer. The 245E is one of the many high quality audio processing products manufactured by Orban Associates, Inc., for the discriminating professional user.

DESCRIPTION

The Orban Stereo Synthesizer processes any monophonic sound source into pseudo-stereo quickly and easily. The pseudo-stereo does not degrade the quality of the mono recording, and possesses many attributes of true stereo, such as depth, space, directionality, stability, and good channel balance.

Mono compatibility is assured by the following facts:

1] The electrical sum of the two output channels is proportional to the mono input to the Synthesizer; and

2] The sum of the left and right powers (as a function of frequency) is proportional to the power in the mono input.

[1] means that a listener can recover the original mono by summing the two stereo channels together. This removes many "purist" objections to pseudo-stereo, since the purist can choose freely between pseudo-stereo and the original mono. It also means that mono FM listeners will hear the original mono source when listening in mono to a stereo FM station.

[2] means that the acoustical frequency balance of the pseudo-stereo is identical to the frequency balance of the mono.

Both [1] and [2] hold for any adjustments of the Stereo Synthesizer operating controls.

INSTALLATION: MECHANICAL

The 245E Stereo Synthesizer requires 1 3/4" of rack space in an EIA standard 19" rack. A mounting position should be chosen which allows the operator to hear a well-balanced stereo image from the studio monitor loudspeakers, since the Stereo Synthesizer is adjusted by ear.

The Stereo Synthesizer will usually pick up its chassis ground from the rack; be sure that the resistance between the rack and the

Stereo Synthesizer chassis is less than 1 ohm. Sometimes it is necessary to scrape the paint from the rack and/or the back of the Stereo Synthesizer front panel to secure a good connection. If the Stereo Synthesizer is to be mounted in a non-conductive enclosure like a portable case, the instructions in the Grounding section (below) should be followed.

It is unwise to mount the Stereo Synthesizer directly over large heat-producing devices like vacuum-tube power amplifiers, because component life can be shortened. Ambient temperature should not exceed 50 degrees C when the unit is powered.

INSTALLATION: ELECTRICAL

General:

The Stereo Synthesizer is designed to be operated at a nominal line level of +4 dBm, although its very low noise permits operation at -10 dBm bus levels sometimes found in broadcast applications. It is unbalanced in and out. Therefore, some care must be taken to avoid ground loops. Audio wiring to and from the Stereo Synthesizer should be made with two-conductor shielded cable (Belden 8450, 8451, or equivalent). The shield should not carry any current, and should be connected to the chassis of either, but not both, of the pieces of equipment it is interconnecting. [Refer to the section on Grounding, below, for more detailed information.]

All audio connections are made on a Cinch-Jones type 140Y terminal strip located on the rear chassis apron. This terminal strip uses a #5 screw. Terminations can be made by means of crimp-on insulated spade lugs, or a fanning strip may be employed if quick connections and disconnections are required.

Power:

The Stereo Synthesizer will operate on either 115 volt 60 Hz or 230 volt 50 Hz, AC power. It can be converted from one standard to the other by rearranging the bare wires on the power transformer according to instructions stamped on the power transformer's insulating cover. It is not necessary to rearrange the insulated wires. The 1/8 amp slo-blo fuse supplied is sufficient for either voltage.

The Stereo Synthesizer is ordinarily shipped strapped for the power standard in its country of destination. Units strapped for 230 volt operation are shipped with a tag on the line cord warning of the modification.

The captive line cord is equipped with a U.S. standard "U-Ground" plug. Users in other countries may have to use an adapter. We do not recommend that the grounding prong be removed from the plug, as this is an important safety feature. Since the chassis and circuit grounds can be unstrapped at the rear-panel connector, we foresee no circumstances which would require breaking the line-cord safety ground connection.

Input:

The input impedance of the Stereo Synthesizer is 25,000 ohms, unbalanced bridging. The GAIN control is located before any active circuitry; therefore, almost any input level can be accepted.

The white (or red) lead of the input cable should be connected to the INPUT terminal on the rear apron of the chassis; the black lead should be connected to circuit ground. The shield should be connected to chassis ground, and should be terminated on only one side.

When the GAIN control is fully clockwise, the Stereo Synthesizer will produce approximately 8 dB of gain in MONO mode. In STEREO mode, peak gain at certain frequencies will be 14 dB.

Output:

The Stereo Synthesizer output is unbalanced with a source impedance of approximately 1 ohm, and can drive +20 dBm into 500 ohm or higher loads. It is not necessary or desirable to terminate the outputs with a resistor if high impedance bridging loads are being driven.

Output connections should be made through two-conductor shielded cable. The inner conductors should be connected to the output and circuit ground terminals; the shield should be connected to chassis ground at one end only.

Grounding:

The general rules for grounding are as follows:

1] The chassis must be grounded. It can pick up its ground either from the ground prong of the power cord, or from the enclosure in which it is mounted. If neither provides a ground path, then the

chassis and circuit ground screws on the rear-apron terminal strip may be linked together.

2] Each piece of equipment must be connected to a common circuit ground by one and one only path. If more than one path exists, ground loops can be formed which will induce hum into the system.

Although best practice calls for a separate ground wire from each piece in the system to a central ground point, it is sometimes possible, in smaller systems, to break the rule regarding termination of the shield wire at one end only, and to use the shield wire in a two-conductor shielded cable to provide the circuit ground connection between two pieces of equipment. This may be necessary if the equipment driving and/or driven by the Stereo Synthesizer has balanced outputs or inputs, since connection of the Stereo Synthesizer circuit ground to the output or input of such equipment will, by definition, not result in connecting the circuit grounds of the two pieces of equipment together.

The general subject of grounding is complex, and is beyond the scope of this manual. For further information, see: [H.M. Tremaine: The Audio Cyclopedia, Second Edition (Indianapolis: Howard W. Sams and Co., Inc., 1969), Section 24]. However, if problems are encountered, the two rules above should serve as useful general guidelines.

OPERATING INSTRUCTIONS

[1] After connecting the Stereo Synthesizer to your system (following the installation instructions above), move to a point equidistant between the monitor speakers.

[2] Introduce mono program to the input of the Stereo Synthesizer. Put the mode switch in MONO. Advance the GAIN control until both channels are peaking about -4 VU (0 dBm) on a standard VU meter. Balance the audio chain following the Stereo Synthesizer for equal left/right levels. You may test for adequate monitor balance by making sure that, when the Stereo Synthesizer is in MONO mode, a well-defined point-source virtual image is heard exactly mid-way between the speakers.

[3] Turn the mode switch to STEREO. Turn the SEPARATION control to 10. Adjust the two DIMENSION controls in different combinations until the stereo image seems well-balanced from left to right, and does not "bunch up" to one side. Do not be disturbed if the stereo VU meters in the following audio system indicate unbalanced levels; you are adjusting for psychoacoustical balance.

With practice, this adjustment will take only a few seconds. For best results, it should be repeated for each new piece of program material. In certain applications, like "in line" in a broadcast automation system following a bank of mono cartridge reproducers, it is not feasible to readjust the DIMENSION controls for each new piece of program material. We have experimented extensively, and feel that a good compromise setting in such a case is HIGH DIMENSION: 7.5; LOW DIMENSION: 3.0.

[4] Adjust the SEPARATION control for the amount of separation desired. This control operates such that the stereo sum signal (L+R) remains constant for any setting, and the stereo difference signal (L-R) is increased from zero to a level equal to the sum signal as the SEPARATION control is advanced from 0 to 10. At "10", the peak level on each channel increases 6 dB with reference to a "0" setting; subjective loudness increases 3 dB. As with any stereo program, for a constant peak level in both channels, total perceived loudness decreases as separation is increased. The highly competitive FM stereo station may therefore wish to reduce the setting of the SEPARATION control in order to sound louder in both stereo and mono. This provides an interesting technique for controlling voice/music balance: if the announce microphone (and/or other voice material) is processed through the Stereo Synthesizer, its loudness relative to the music may be controlled by adjusting the setting of the SEPARATION control.

Separation, of course, may also be reduced if the effect sounds exaggerated. Any time that separation is reduced, the setting of the GAIN control must be increased to retain constant peak levels at the Stereo Synthesizer output.

The output of the Stereo Synthesizer can drive any device requiring standard line levels and impedances. If gain balance is carefully maintained after the Stereo Synthesizer, then the following relationships will hold accurately:

- a] If the Stereo Synthesizer output is recorded on a tape or cartridge recorder having substantial time delay or phase shift between the two channels, the "phasing" sound on the mono sum signal will be greatly reduced on playback.
- b] In disc cutting, the lateral cut will be the original mono input of the Stereo Synthesizer. Paralleling the channels of a stereo pickup will result in reproduction of the original mono source.
- c] In FM stereo broadcasting, mono listeners will hear the original mono signal.

PERFORMANCE TEST

The following tests will verify that the Stereo Synthesizer is operating correctly:

1] Connect a low-distortion sinewave oscillator (like the oscillator section of the Sound Technology 1700/1710-series distortion-measuring set) to the input of the Stereo Synthesizer. Load each Stereo Synthesizer output with a 620 ohm 5% 1/4 watt resistor. Turn the stereo/mono switch to MONO. Adjust the oscillator output level and Stereo Synthesizer GAIN control to produce approximately +18 dBm at each output. Measure the Total Harmonic Distortion at 20 Hz, 1 kHz, and 20 kHz. It should not exceed 0.5% at any frequency, and will typically be 0.1% or below.

2] Remove the oscillator and turn the GAIN control to "0". Measured through a 20-20,000 Hz bandpass filter with 18 dB/octave Butterworth (maximally flat) skirts, the noise should not exceed -80 dBm from either output channel. Be careful that no hum is introduced by ground loops in the measurement setup.

3] Center the DIMENSION controls. Adjust the SEPARATION control to "10". Turn the stereo/mono switch to STEREO. Measure the frequency response of the left and right channels (most conveniently done with a sweep generator, or with a test set like the Tektronix 5L4N). The frequency responses of the two channels should resemble those shown in fig. (1). Note that the DIMENSION controls will affect the frequencies of the nulls shown in fig. (1).

If these tests are passed, there is a high probability that the Stereo Synthesizer is operating properly.

MAINTENANCE

Preventive Maintenance:

The front panel may be cleaned with a mild household detergent. Stronger solvents should be used with great caution, as they may damage the paint, the silk-screened lettering, and the plastic control knobs.

The interior of the Stereo Synthesizer should be kept free from dust and dirt, since dirt buildup inside the chassis can cause loss of cooling and also can result in high-resistance short circuits if the dirt absorbs moisture from the air. It is particularly important in a dusty or humid environment that the covers be periodically removed and the interior of the chassis cleaned.

Factory Service:

If your Stereo Synthesizer should develop problems during its first year of use, please refer to the Orban Associates, Inc. Standard Warranty for instructions on how to obtain warranty repairs. The Warranty is on a separate sheet and is not bound with this manual. After expiration of the warranty, a reasonable charge will be made for parts, labor, and packing if you choose to utilize the factory service facility. In all cases, transportation charges (which are usually quite nominal) shall be borne by the customer.

Before returning the Stereo Synthesizer for repair, please write or telephone for instructions, stating the trouble experienced. Often a problem can be solved by consultation, saving you the time and expense required to return the unit to the factory.

In all cases, use the following shipping address to obtain factory service:

ORBAN ASSOCIATES, INC.
645 BRYANT STREET
SAN FRANCISCO, CA. 94107

telephone (415) 957-1067

Replacement of Components on Printed Circuit Boards:

It is important to use the correct technique for replacing components mounted on PC boards. Failure to do so will result in possible circuit damage and/or intermittent problems. Fortunately, the Stereo Synthesizer employs an easily-repairable single-sided PC board.

Use the following technique to replace a component:

1] Use a 30 watt soldering iron to melt the solder on the foil side of the PC board. Do not use a soldering gun or a high-wattage iron! As soon as the solder is molten, vacuum it away with a spring-actuated desoldering tool like the Edsyn "Soldapullt". Avoid overheating the board; overheating will almost surely damage the board by causing the conductive foil to separate from the board base. Use a pair of fine needle-nose pliers to wiggle the lead horizontally until it can be observed to move freely in the hole.

2] Repeat step (1) until each lead to be removed has been cleared of solder and freed.

3] Now lift the component out.

4] Bend the leads of the replacement component until it will fit easily into the appropriate PC board holes. Using a good brand of rosin-core solder, solder each lead to the board with a 30 watt soldering iron. Make sure that the joint is smooth and shiny.

5] Cut each lead of the replacement component as close as possible to the foil side of the PC board with a pair of diagonal cutters.

6] Remove all residual flux with a cotton swab moistened with a solvent like 1,1,1 trichloroethane, naphtha, or 99% isopropyl alcohol. The first two solvents are usually available in supermarkets under the brand name "Energine" fire-proof spot remover and regular spot remover, respectively. The alcohol, which is less effective, is usually available in drug stores. Rubbing alcohol is highly diluted with water and is ineffective.

It is good policy to make sure that this defluxing operation has actually removed the flux and has not just smeared it so that it is less visible. While rosin flux is not corrosive, it can slowly absorb moisture and become sufficiently conductive to cause progressive deterioration of performance.

Troubleshooting IC Opamps:

IC opamps are operated such that the characteristics of their associated circuits are essentially independent of IC characteristics and dependent only on external feedback components. The feedback forces the voltage at the (-) input terminal to be extremely close to the voltage at the (+) input terminal. Therefore, if the technician measures for than a few millivolts between these two terminals, the IC is probably bad.

Exceptions are IC's used without feedback (as comparators) and IC's whose outputs have been saturated due to excessive input voltage because of a defect in an earlier stage. However, if an IC's (+) input is more positive than its (-) input, yet the output of the IC is sitting at -14 volts, this almost certainly indicates that it is bad. The same holds if the above polarities are reversed.

SHIPPING INSTRUCTIONS

If the original packing material is available, it should be used. Otherwise, a carton of at least 200 pounds bursting test and no smaller than 22" x 15" x 9" should be employed.

The Stereo Synthesizer should be packed so that there is at least 1-1/2" of packing material protecting every point. Cushioning material such as Air-Cap, Bubble-Pak, foam "popcorn", or fibre blankets are acceptable. Folded newspaper is not suitable. Blanket-type materials should be tightly wrapped around the Stereo Synthesizer and taped in place to prevent the unit from shifting out of its packing and contacting the walls of the carton.

The carton should be packed evenly and fully with the packing material filling all voids such that the unit cannot shift in the carton. Test for this by closing but not sealing the carton and shaking vigorously. If the unit can be felt or heard to move, use more packing.

The carton should be well-sealed with 3" reinforced sealing tape applied across the top and bottom of the carton in an "H" pattern. Narrower or parcel-post type tapes will not stand the stresses applied to commercial shipments.

The package should be marked with the name of the shipper, and the words in red: DELICATE INSTRUMENTS, FRAGILE!. Even so, the freight people will throw the box around as if it were filled with junk. The survival of the unit depends almost solely on the care taken in packing!

CIRCUIT DESCRIPTION (With Troubleshooting Hints)

Signal Processing Circuitry:

The signal enters and is attenuated by R1, the GAIN control. The non-inverting unity-gain buffer IC1A which follows R1 provides light loading for R1. It also provides low impedance drive for R2 (the SEPARATION control) and for matrix resistors R18,R23.

R2 drives a chain of four phase shifters. These have a frequency response which is flat, but a phase response which changes as a function of frequency. The phase-shifted signal produced by these phase shifters becomes the stereo difference signal (L-R), while the original mono signal from the output of IC1B becomes the stereo sum signal (L+R). Matrixing of the sum and difference signals to provide the left and right channels occurs in the circuitry associated with IC3, and will be described below.

R2 (SEPARATION) is an L-R gain control. Its output is buffered by IC1B. The output of IC1B drives a two-pole active phase shifter consisting of R3-9, C7,8, and IC2A. This

phase shifter is essentially a bridge circuit. IC2A is used as a differential amplifier to convert the bridge output from a floating, differential voltage to a single-ended, ground-referenced voltage to drive following stages.

Frequency response at the output of IC2A should be flat + 1 dB from 20-20,000 Hz. Substantial deviation from flatness implies a failure or severe drift in one or more of the components associated with IC2A. Since all of the components interact, each component must be individually removed and tested with an impedance bridge to determine the cause of the problem.

The output of IC2A drives a single-pole adjustable phase shifter consisting of R10-13, C9, and IC2B. The 90 degree phase shift frequency of this circuit is in the lower midrange. The exact 90 degree frequency is adjustable with R15, the LOW DIMENSION control. Like its predecessor, this circuit is also a bridge. IC2B acts as a differential amplifier to convert the output to a ground-referenced voltage signal.

The output of IC2B drives a final phase shifter, consisting of R14-17, C10, and IC3A. The operation of this phase shifter is fundamentally similar to its predecessor, and incorporates the HIGH DIMENSION control. However, IC3A is also the left channel output driver amplifier. It has a discrete output stage to drive 600 ohm loads, and it has an extra input: the original input signal is added through R18 to the phase shifted signal. Therefore, the output of IC3A is actually the phase shifted signal added to the original signal, yielding the synthesized left channel. This left channel has a frequency response consisting of several dips. The typical frequency response is shown in fig. (1). The depth of the dips is controlled by the SEPARATION control, R2.

The output of IC3A consists of the phase-shifted difference signal plus the inverted sum signal, since R18 is connected to the (-) input of IC3A. The right channel is synthesized by adding two times the inverted sum signal to the inverted left channel. Thus the right channel contains two components:

- 1] $-2S - (-S) = -S$; and
- 2] $-D$

where S is the sum (L+R) signal, and D is the difference (L-R) signal.

Thus both left and right channels contain -S (i.e., the Stereo Synthesizer is inverting from input-to-output), but both S components are in-phase with each other. In addition, the left and right channels contain difference components that are out-of-phase

with each other. Mathematically,

$$L = -S + D$$

$$R = -S - D$$

The -2S component is supplied through R23; R24 supplies the left channel component.

IC3 is frequency-compensated by R19,26, C11,12 to prevent high frequency oscillations. Each amplifier in IC3 is followed by a class AB complementary-symmetry discrete output stage which permits the outputs of the Stereo Synthesizer to drive 600 ohm loads to peaks of approximately +21 dBm. We will consider the left output stage; the right output stage is identical.

The output of IC3A is the collector of a PNP transistor. The collector load of this internal transistor consists of diode-connected transistors Q2,3, and load resistor R22. The voltage drop across Q2,3 biases Q1,4 slightly on at all times, thus forcing class AB operation to avoid crossover distortion. Thermal feedback to prevent thermal runaway is provided by strapping Q2 to Q1 and Q4 to Q3.

Q1,4 are emitter followers. R20,21 develop voltage drops proportional to the current through Q1,4. This provides local DC feedback to help stabilize the operating current through Q1,4. In addition, R20,21 work with D5,6 to provide short-circuit protection. If the current through Q1,4 causes a voltage drop across R20,21 in excess of about 0.55 volts, D5,6 will turn on, thus shunting drive current away from Q1,4 into the load and protecting Q1,4 from burnout due to excessive collector current and power dissipation.

Power Supply:

The unregulated power supply consists of a power transformer T1 and two full-wave rectifiers D1-4 with associated energy-storage capacitors C1,2. The unregulated voltage may be expected to vary between 18 and 25 volts depending on line and load conditions.

Regulated voltage is developed by an IC voltage regulator IC4 which provides the necessary + 15 volts for the signal processing circuitry. The outputs of IC4, a RC4195DN Dual Regulator (Raytheon Semiconductor), may be expected to vary from + 14.5 to + 15.5 volts depending on the characteristics of individual IC. The absolute values of the two output voltages should be within 0.3 volts of each other.

IC4 has complete internal protection against short circuits and thermal overload, and will shut down if excessive current demand exists elsewhere in the circuit. Therefore, absence of regulated voltage does not necessarily mean that IC4 is defective.

Normal supply current under no-signal conditions is approximately + 22 ma. Typical ripple is 0.7 mv average over a 20-20,000 Hz band.

IC4 is frequency-compensated by C3,4 to prevent high frequency oscillations. C3,4 must be low-inductance aluminum electrolytics. If C3 or C4 is replaced, do not use a tantalum or high-inductance electrolytic. The former can fail because fault current is not limited; the latter can fail to suppress high frequency oscillations.

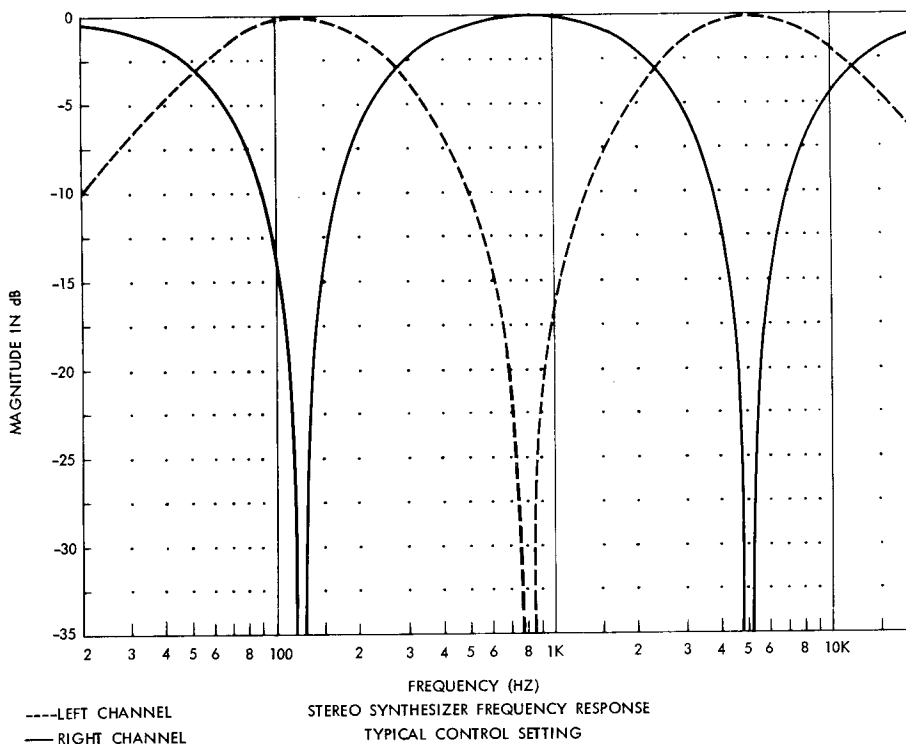

APPENDIX A: SPECIFIC APPLICATIONS

Recording Studios:

- 1] Save tracks by recording strings, horns, drums, etc. on single tracks and then spatially expanding them in the mix.
- 2] Create stereo depth from intrinsically mono sources like electronic music synthesizers, string synthesizers, guitar or bass amplifiers, electronic organs, etc.
- 3] Obtain a stereo echo return from a mono echo chamber, plate, or spring reverb.
- 4] Use one output channel to create phasing effects by manipulating the DIMENSION controls while signal is being passed.
- 5] Create a stereo effect from old mono master tapes, discs, or even 78's.

Broadcasting:

- 1] Create a stereo effect from a mono announce microphone without image shifting caused by the announcer's moving his head. Use the SEPARATION control to determine voice/music balance.
- 2] If stereo cart machines are used: Record all mono material through the Stereo Synthesizer before it is recorded on cartridge. The phase cancellations in the mono mix heard by mono listeners will be greatly reduced compared to cancellations heard when the same mono signal is recorded on both tracks. This is because most frequencies appear unequally on left and right channels; thus most frequencies can't cancel out effectively in mono.
- 3] If mono cart machines are used: Place the Stereo Synthesizer on the output of the entire bank of machines, using the compromise adjustment -- LOW DIMENSION=3.0; HIGH DIMENSION=7.5. Mono phase cancellations will be eliminated entirely; stereo listeners will hear highly effective pseudo-stereo.
- 4] Process mono agency spots, network feeds, and remotes to create a "total stereo" format.

Projection Television:

The effectiveness of projection television sound (such as the Advent or General Electric systems) can be quite

spectacularly augmented by employing the Stereo Synthesizer to create pseudo-stereophonic sound. The Stereo Synthesizer is equally applicable to commercial installations like bars or restaurants, or to the home.

APPENDIX B: SPECIFICATIONS

FREQUENCY RESPONSE OF THE STEREO SUM SIGNAL:
± 1 dB (re mono input)

FREQUENCY RESPONSE OF THE SUM OF THE RIGHT AND LEFT CHANNEL POWERS:

± 1 dB (re mono power)

TOTAL HARMONIC DISTORTION [+19 dBm, 20-20,000 Hz]: <0.5%; 0.1% typ.

NOISE [Unweighted, 20-20,000 Hz]: <-80 dBm; -83 dBm typ.

AVAILABLE GAIN: approximately 8 dB [mono]; 14 dB peak [stereo]

INPUT: 25,000 ohms, unbalanced bridging

OUTPUT: <10 ohms unbalanced. Will drive >+19 dBm, 20,20,000 Hz into 500 ohms or higher load impedance.

INPUT/OUTPUT CONNECTOR: Type 140-Y barrier strip (#5 screw)

POWER REQUIREMENTS: 115-230 volt 50-60 Hz AC, ± 10%, 2 watts.

Supplied with "U-Ground" grounding-type plug to United States standards.

MOUNTING: requires 1 3/4" (4.45 cm) of vertical space in an EIA standard 19" (48.26 cm) rack.

SHIPPING WEIGHT: 7 pounds (3.175 kg)

PART LISTINGS

APPENDIX C

REFERENCE DESIGNATOR LISTING

30055-000 ASY MOTHERBOARD, 245E

REF. DES.	PART #	DESCRIPTION
C001	21224-747	CAP ALUM, AXIAL 40V 470 MFD
C002	21224-747	CAP ALUM, AXIAL 40V 470 MFD
C003	21213-610	CAP ALUM, AXIAL 25V 10 MFD
C004	21213-610	CAP ALUM, AXIAL 25V 10 MFD
C005	21106-350	CAP CERAMIC, 20%, 25V, .05 MFD
C006	21106-350	CAP CERAMIC, 20%, 25V, .05 MFD
C007	21502-262	CAP POLYSTYRENE, 5%, 160V, .0062 MFD
C008	21409-347	CAP POLYESTER, AXIAL, 80V, 5%, .047 MFD
C009	21401-347	CAP POLYESTER, RAD, 100V, 10%, .047 MFD
C010	21401-247	CAP POLYESTER, RAD, 100V, 10%, .0047 MFD
C011	21401-322	CAP POLYESTER, RAD, 100V, 10%, .022 MFD
C012	21401-322	CAP POLYESTER, RAD, 100V, 10%, .022 MFD
CR001	22201-400	DIO RECTIFIER, 1A, MOTOROLA 1N4004
CR002	22201-400	DIO RECTIFIER, 1A, MOTOROLA 1N4004
CR003	22201-400	DIO RECTIFIER, 1A, MOTOROLA 1N4004
CR004	22201-400	DIO RECTIFIER, 1A, MOTOROLA 1N4004
CR005	22101-000	DIO SIGNAL, FAIRCHILD 1N4148
CR006	22101-000	DIO SIGNAL, FAIRCHILD 1N4148
CR007	22101-000	DIO SIGNAL, FAIRCHILD 1N4148
CR008	22101-000	DIO SIGNAL, FAIRCHILD 1N4148
IC001	24202-202	IC LIN, DUAL OPAMP, RAYTHEON RC4558NB
IC002	24202-202	IC LIN, DUAL OPAMP, RAYTHEON RC4558NB
IC003	24201-302	IC LIN, DUAL OPAMP, FAIRCHILD F749C, GD. C
IC004	24302-201	IC P.S. REGULATOR, RAYTHEON RC4195DN
Q001	23202-101	TRA SIG, NPN, FAIRCHILD 2N4400
Q002	23202-101	TRA SIG, NPN, FAIRCHILD 2N4400
Q003	23002-101	TRA SIG, PNP, FAIRCHILD 2N4402
Q004	23002-101	TRA SIG, PNP, FAIRCHILD 2N4402
Q005	23202-101	TRA SIG, NPN, FAIRCHILD 2N4400
Q006	23202-101	TRA SIG, NPN, FAIRCHILD 2N4400
Q007	23002-101	TRA SIG, PNP, FAIRCHILD 2N4402
Q008	23002-101	TRA SIG, PNP, FAIRCHILD 2N4402
R003	20041-121	RES MF, 1/8W, 1% 1.21K
R004	20041-453	RES MF, 1/8W, 1% 4.53K
R005	20042-332	RES MF, 1/8W, 1% 33.2K
R006	20043-127	RES MF, 1/8W, 1% 127.0K
R007	20001-327	RES CF, 1/4W, 5% 27K
R008	20001-420	RES CF, 1/4W, 5% 200K
R009	20001-330	RES CF, 1/4W, 5% 30K
R012	20001-330	RES CF, 1/4W, 5% 30K
R013	20001-330	RES CF, 1/4W, 5% 30K
R016	20001-310	RES CF, 1/4W, 5% 10K
R017	20001-330	RES CF, 1/4W, 5% 30K
R018	20001-315	RES CF, 1/4W, 5% 15K
R019	20001-015	RES CF, 1/4W, 5% 15 OHM
R020	20001-015	RES CF, 1/4W, 5% 15 OHM
R021	20001-015	RES CF, 1/4W, 5% 15 OHM
R022	20001-247	RES CF, 1/4W, 5% 4.7K
R023	20001-275	RES CF, 1/4W, 5% 7.5K
R024	20001-330	RES CF, 1/4W, 5% 30K
R025	20001-330	RES CF, 1/4W, 5% 30K
R026	20001-015	RES CF, 1/4W, 5% 15 OHM
R027	20001-015	RES CF, 1/4W, 5% 15 OHM
R028	20001-015	RES CF, 1/4W, 5% 15 OHM
R029	20001-247	RES CF, 1/4W, 5% 4.7K
R030	20001-510	RES CF, 1/4W, 5% 1M

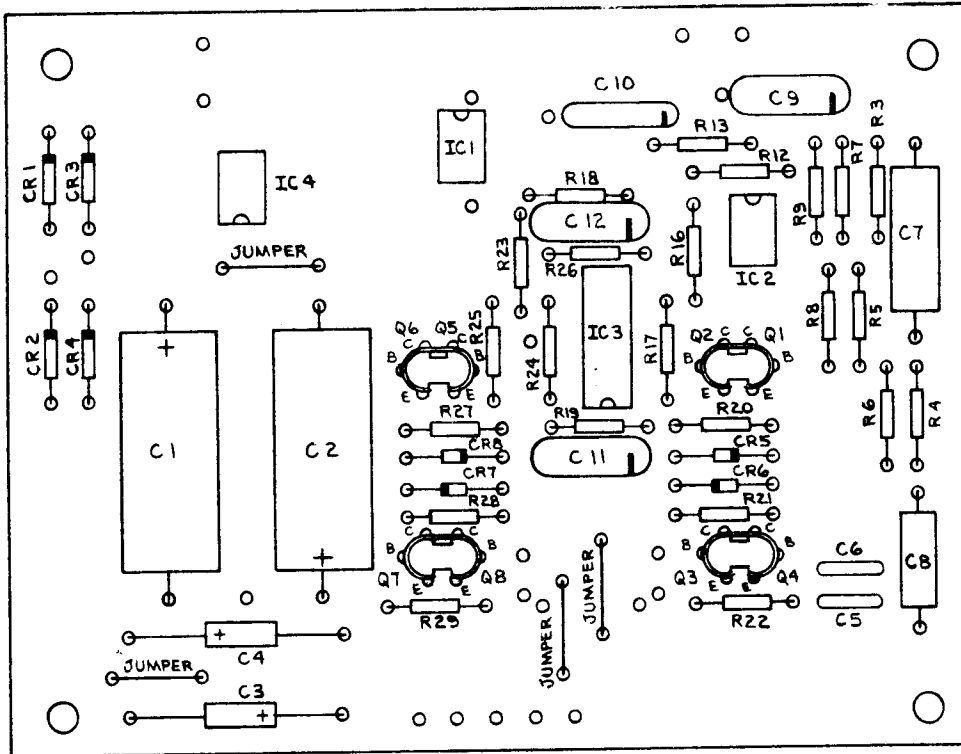

ASSEMBLY DRAWING, MOTHERBOARD
 MODEL 245E STEREO SYNTHESIZER

30055-000-05

COPYRIGHT © BY ORBAN ASSOCIATES INC. 1977, 1979

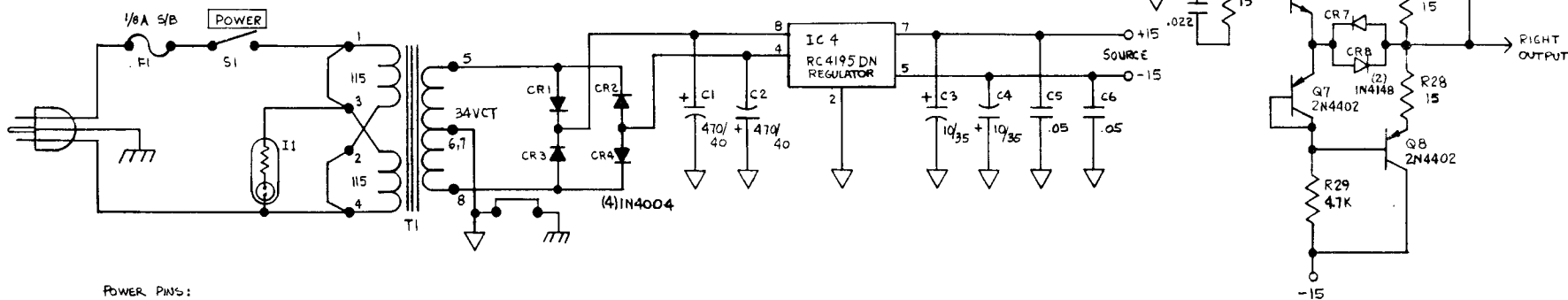
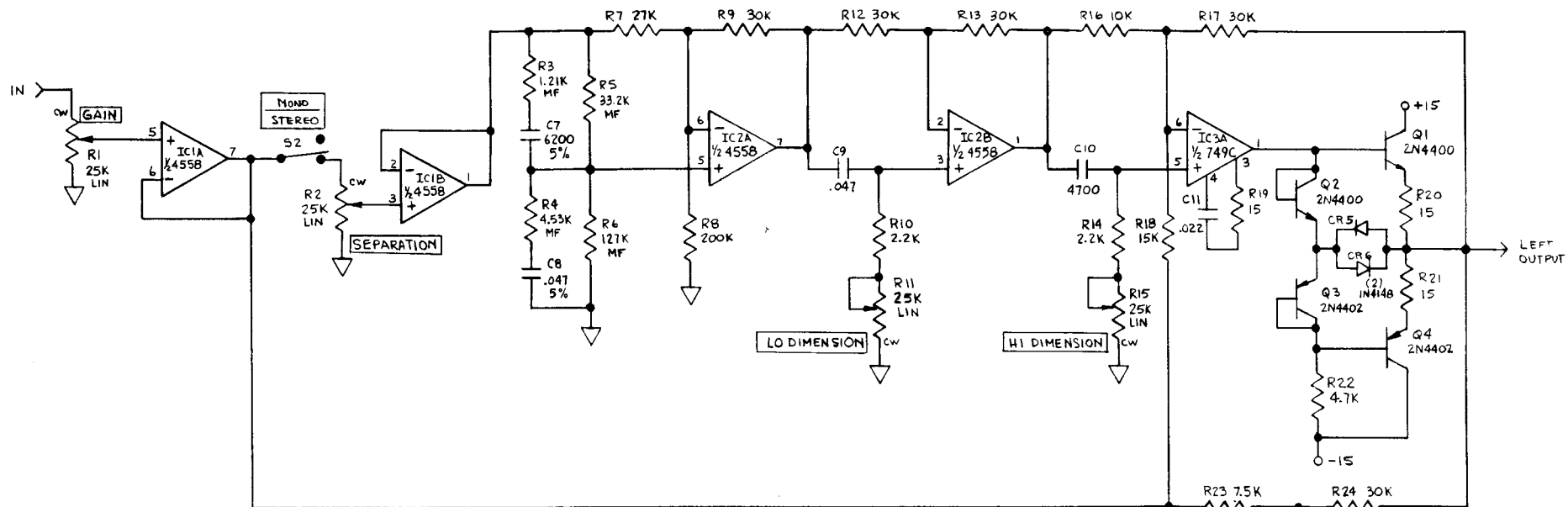

POWER PINS:

DEVICE	W	V
4558	8	4
749C	14	7

- RESISTORS DESIGNATED 'MF' ARE RN55D STYLE - 1/8 W 1%,
 ALL OTHERS ARE CARBON FILM, 1/4 W 5%
 - THIS DESIGN IS PATENTED : U.S. 3670106, U.K. 1264659, CAN. 900864, OTHERS PENDING