

# Owner's Manual

## LXP-1 Multi-Effects Processing Module

**lexicon**

## Table of contents

Precautions .....	ii
FCC Notice .....	iv
Introduction .....	v
Specifications .....	vi
<b>1. Installing the LXP-1 .....</b>	<b>1-1</b>
Unpacking .....	1-1
Mounting .....	1-1
Power .....	1-1
LXP-1 front panel controls .....	1-2
LXP-1 rear panel connections .....	1-3
Audio connections .....	1-4
<b>2. Operating the LXP-1 .....</b>	<b>2-1</b>
Setting audio levels .....	2-1
DEFEAT switch operation .....	2-3
Selecting LXP-1 preset programs .....	2-3
Changing parameters .....	2-3
Descriptions of programs and parameters .....	2-5
Program table: Reverbs .....	2-9
Program table: Reverb and delay effects .....	2-10
<b>3. MIDI operations .....</b>	<b>3-1</b>
Introduction .....	3-1
Accessing LXP-1 registers .....	3-1
Using Dynamic MIDI® .....	3-4
The LXP-1 and MIDI System Exclusive data .....	3-8
<b>4. MIDI implementation data .....</b>	<b>4-1</b>



## ***FCC Notice***

### ***Class A Computing Device***

This equipment generates, uses, and can radiate radio frequency energy. If not installed and used in accordance with the instruction manual, it may cause interference to radio communications. It has been tested and found to comply with the limits for a Class A computing device pursuant to Subpart J, Part 15 of FCC Rules, which are designed to provide reasonable protection against such interference when operated in a commercial environment. Operation of this equipment in a residential area may cause interference, in which case the user at his/her own expense will be required to take whatever measures are needed to correct the interference.

The Federal Communications has prepared a booklet which you may find useful:

"How to Identify and Resolve Radio-TV Interference Problems"

This booklet is available from the US Government Printing Office, Washington, DC 20402, Stock No. 004-000-0345-4.

## ***Introduction***

Congratulations on your purchase of the LXP-1 Multi-Effects Processing Module! You are about to experience superb sound quality, a full range of reverberation and effects, fast intuitive editing of preset sounds, and an industry-leading MIDI implementation.

Like Lexicon's other pace-setting products, the LXP-1 offers a rich and distinctive palette of special effects to enhance any audio production. From gated and inverse reverberation to stereo delays and flanging, the LXP-1 delivers superior performance. Whether you are a producer, engineer, or musician—whether you work on stage or in the studio—the LXP-1 will quickly become an indispensable part of your sound.

Unlike other half-rack sized units, the LXP-1 doesn't force you to live with the same sounds everybody else is using. Each program has two variable parameters that you can adjust for subtle or dramatic changes in the program's sound. And with Lexicon's optional MRC (MIDI Remote Controller) you can access as many as eight variable parameters per program for truly world-class flexibility and control.

We're confident you'll find that the LXP-1's unique combination of state-of-the-art sound and extraordinary versatility is exactly what you're looking for. To make sure you don't miss out on anything, we'd like you to read this book. It contains the information you need to access the full power of the LXP-1.

## Specifications

The following specifications are subject to change without notice

Frequency Response	20 Hz - 15 kHz, $\pm$ 1.0 dB (Wet) 20 Hz - 20 kHz, $\pm$ 0.5 dB (Dry)
Dynamic Range	85 dB, typical
Minimum Input Signal	-20 dB
Total Harmonic Distortion (THD)	< 0.07% @ 1 kHz (Wet) < 0.05% @ 1 kHz (Dry)
Input Impedance	50 kilohm (Stereo) 25 kilohm (Mono)
Output Impedance	600 ohm
Signal Level Indication	Signal Detect (Green) Processed Signal Overload (Red)
Defeat	1/4" tip/sleeve phone jack for connection to any on/off toggle switch. Closed condition enables defeat mode.
Connections	Inputs: 1/4" tip/sleeve phone jack Outputs: 1/4" tip/sleeve phone jack Defeat:: 1/4" tip/sleeve phone jack Power: 5.00 mm/2.5mm MIDI In: 5-pin DIN MIDI Thru: 5-pin DIN
Power	9 VAC, 1 A AC wall transformer (supplied)
Dimensions	8" W x 1.7" H x 8" D (203.2 x 43.2 x 203.2 mm)
Weight	3.5 lb (1.59 kg)
Environment	0 - 35°C (32 - 95°F)

## 1. Installing the LXP-1

### Unpacking

After unpacking the LXP-1, save all packing material in case you ever need to ship the unit. Thoroughly inspect the LXP-1 and its packing material for signs of damage in shipment. Report any damage to the carrier at once. The following accessories are included with the LXP-1:

1. Owner's Manual (070-06023)
2. Power pack (USA: 470-06048)
3. Warranty card (USA only)

### Mounting

The LXP-1 measures 8" W x 1.7" H x 8" D (203.2 x 43.2 x 203.2 mm). The optional rack mounting kit (070-06534) handles one or two LXP-1's in a single rack space. Whatever mounting method you use, make sure that the LXP-1 is securely fastened (i.e., screwed) to the rack adaptor—"friction fit" or double-stick tape installations may allow units to come loose during transportation, resulting in damage.

Maximum ambient operating temperature is 35°C (95°F). Provide adequate ventilation if the LXP-1 is mounted in a closed rack with heat-producing equipment such as synthesizer modules, effects units, or power amplifiers. Avoid mounting LXP-1 units directly above power amplifiers.

### Power

Connect the LXP-1 power pack to an appropriate AC wall socket, and the cable end to the LXP-1 power connector. The LXP-1 must be used only with the supplied power pack. Voltage requirements are printed on the power pack. The LXP-1 has no power switch—it can be left on all the time. To keep the power plug from working loose from the rear of the unit during travel, you may wish to apply a small amount of silicone sealer to the plug after inserting it.



## LXP-1 front panel controls

**Level indicators.** The left LED indicates signal present; the right flashes red when the signal is -3 dB from peak overload.

**OUTPUT.** Controls the signal level sent to the LXP-1's outputs.

**MIDI button and status indicator.** The MIDI button is used with an external MIDI device to select a MIDI channel, store registers and learn patches. The status indicator confirms that power is on, and blinks at different rates to inform you of the LXP-1's status.

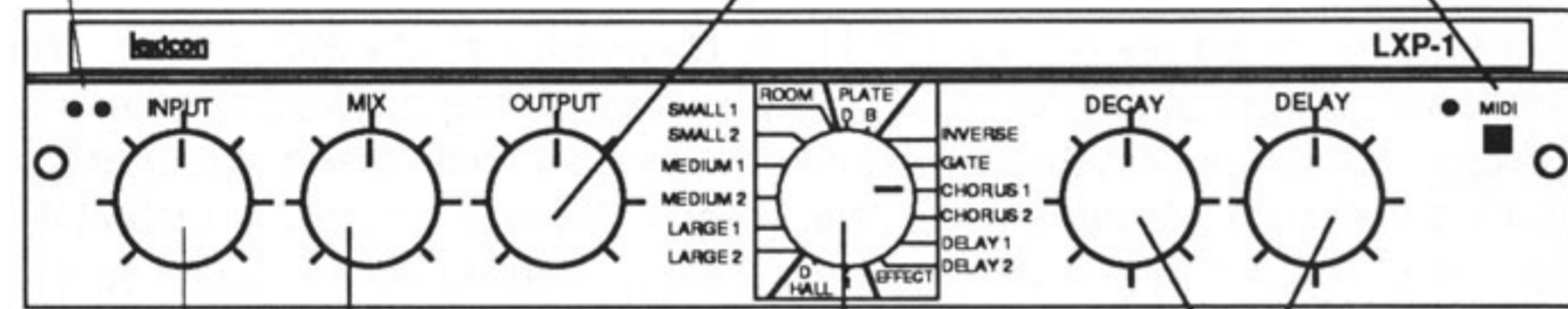

**INPUT.** Sets the audio input level.

**MIX.** Controls the ratio of dry (source) vs. wet (effect) signal present at the LXP-1 outputs. Turn the control all the way to the left for 100% dry, 0% wet. Straight up is 50% dry, 50% wet. All the way to the right is 0% dry, 100% effect.

**Program Selector.** Selects any one of sixteen preset programs for immediate use. 128 user registers can also be stored and recalled via MIDI.

**Parameter Controls.** Allow adjustment of two variable parameters in the currently running preset program or register.

## LXP-1 rear panel connections

**MIDI IN.** Receives MIDI information from other MIDI equipment, such as master keyboard controllers, MIDI foot controllers, sequencers, and synthesizers.

**DEFEAT.** Connect a push-on/push-off (toggle) footswitch here to turn effects on and off.

**INPUTS (L and R).** Single-ended (unbalanced) inputs accept levels from -20 to +15 dBV. Input impedance is 50 kilohms in stereo, and 25 kilohms in mono.

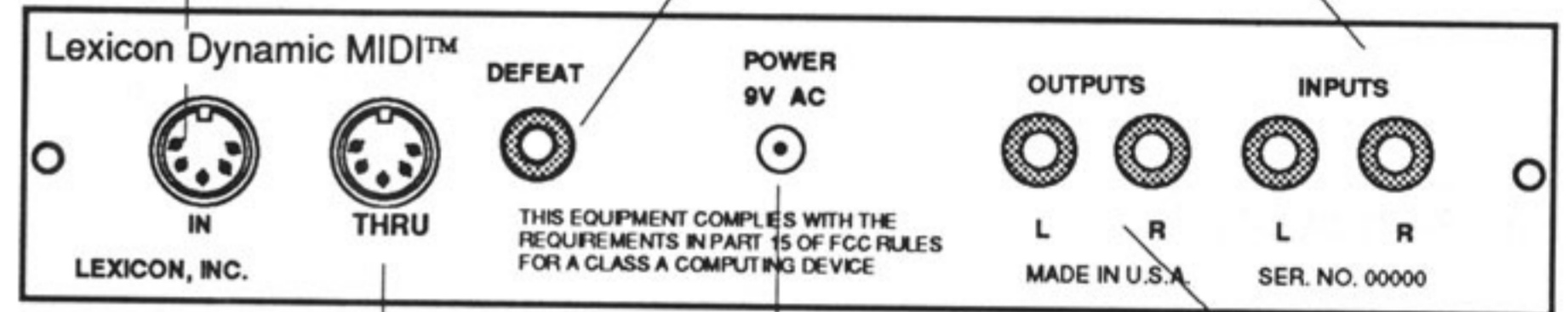

**MIDI THRU.** Any data received at the MIDI IN connector is sent here without change. An internal jumper can be set to change this into a MIDI OUT connector.

**POWER.** Accepts power from the supplied power pack.

**OUTPUTS (L and R).** Single-ended (unbalanced) stereo outputs provide up to +4dBV output into 600 ohms.

## Audio connections

This section outlines several connection possibilities for the LXP-1. Every sound system is unique, so we recommend experimentation to arrive at the best configuration for you. Always check connections for proper impedance, polarity, and levels.

Audio connections to the LXP-1 are unbalanced, and should be made with high quality shielded cables with 1/4" tip-sleeve phone jacks at the LXP-1 end. The connectors must be wired as shown below:

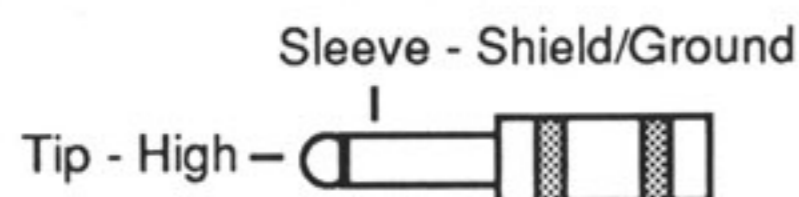

### Mono or stereo?

The LXP produces wonderful stereo effects from both mono and stereo signal sources. For mono sources, use either of the two input connectors; the dry signal appears in mono at both output connectors along with the stereo effects. For instruments and sources with stereo outputs, use both inputs. We recommend using the LXP-1 outputs in stereo whenever possible, but if mono output is required, you can use just one of the two output connectors. The left and right signals are summed internally when only one output is used.

Some of the examples on the following pages use stereo instruments and amplification systems, and others use mono. Feel free to adapt the examples to your specific requirements.

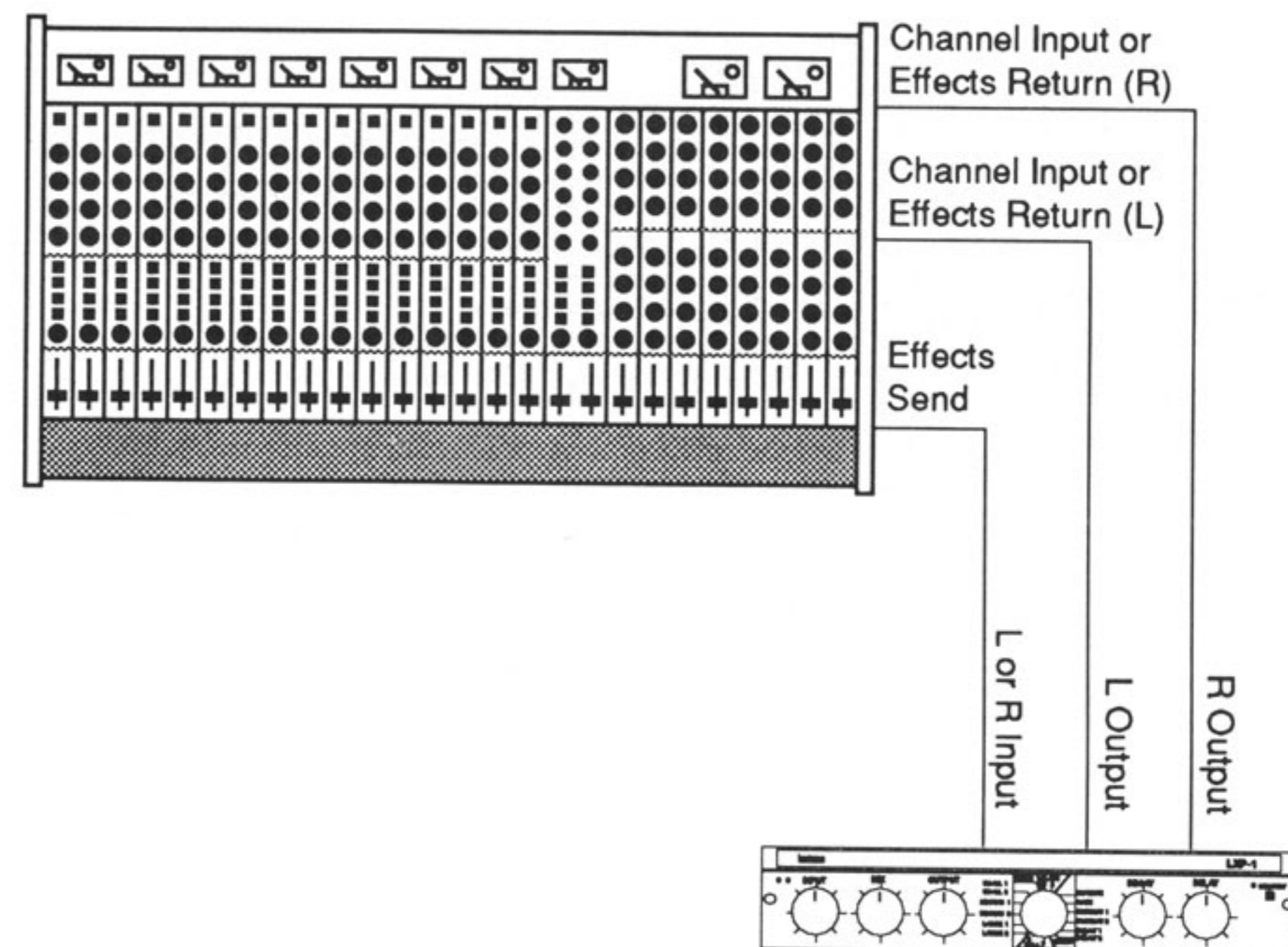

### Connection to a mixing console's effects sends

If you will be using an LXP-1 as your primary effects or reverb unit, and your system includes a console with one or more auxiliary (effects) sends, connect the LXP-1 as shown above. In most applications, it is preferable to connect the LXP-1's outputs to two of the console's input channel strips, panned full left and right, rather than the effects returns. This allows greatest flexibility in routing and equalization.

In this configuration the console controls are used to set the amount of effect heard—the LXP-1's front panel MIX control should be set all the way to the right for 100% wet.



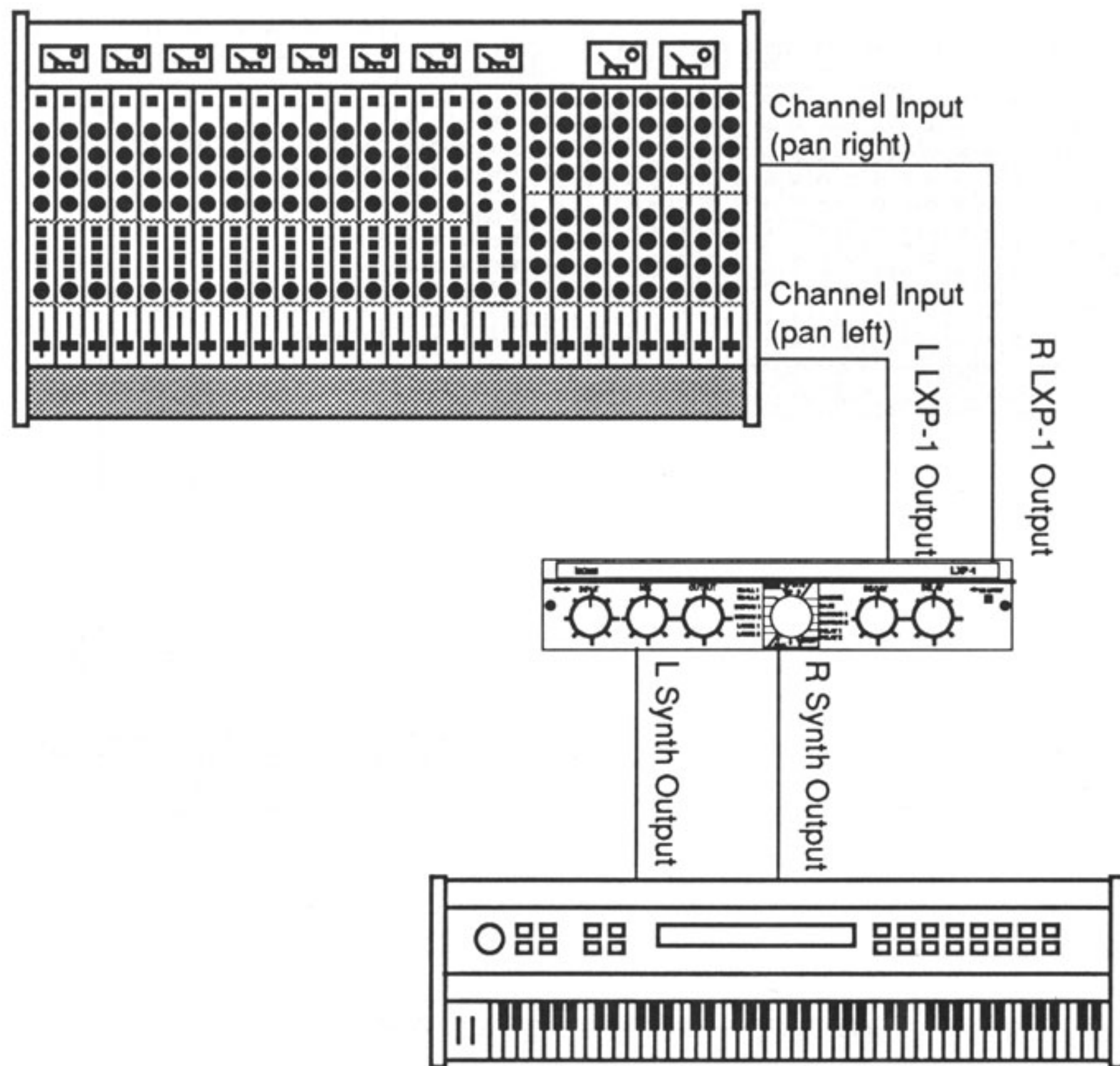

### Connection between instrument and console

In some applications (such as when an LXP-1 is used for a single instrument) it may be desirable to patch the LXP-1 between the instrument and console. This makes it possible to keep the LXP-1 up on stage with other MIDI gear, rather than in the console effects rack, making MIDI control much easier.

In this configuration, the LXP-1's front panel MIX control is used to set the balance between wet and dry sound.

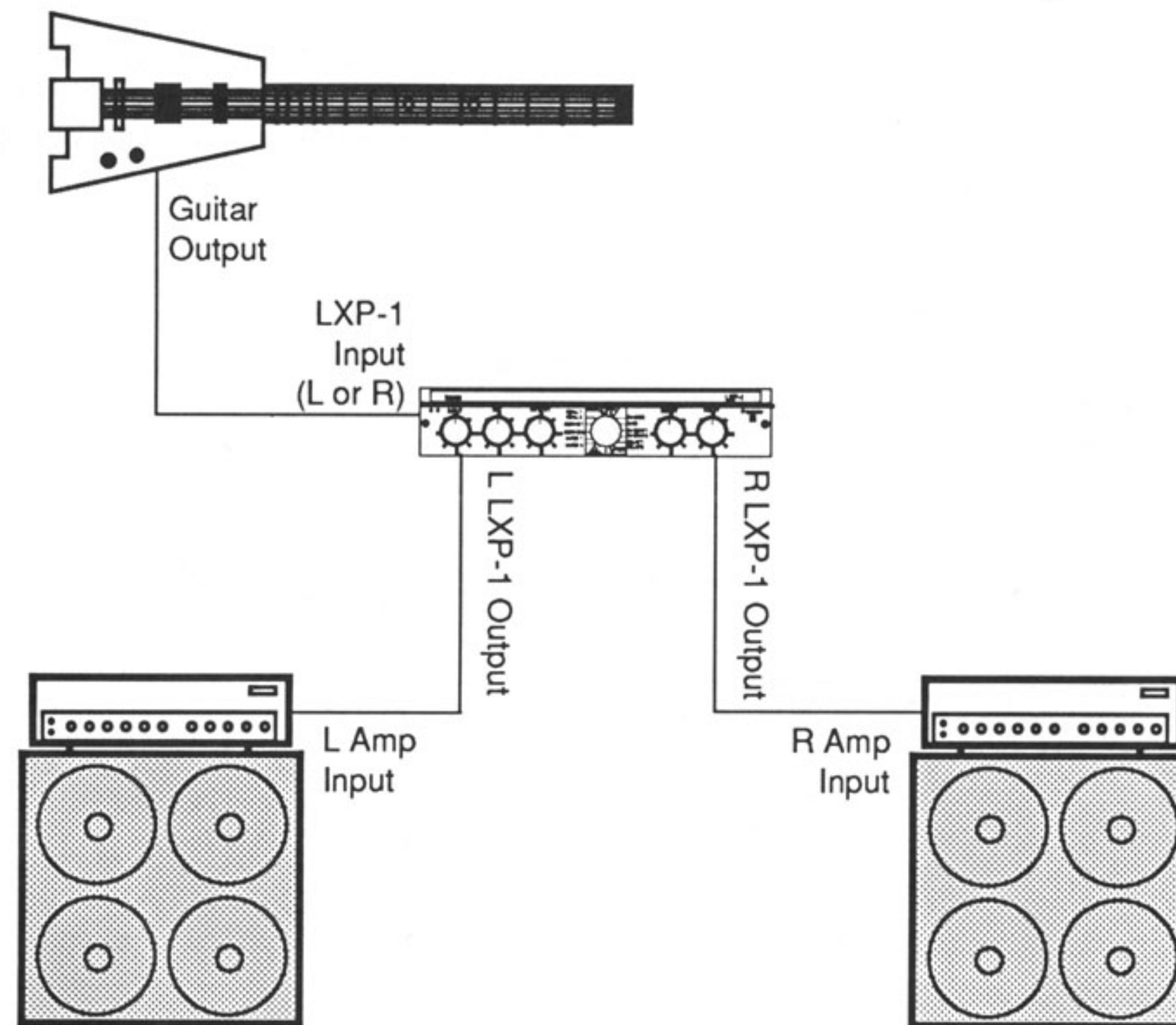

### Connection between instrument and amplifier

For a very spacious guitar sound, connect the LXP-1 between a guitar and two amp and speaker stacks. The only problem with this setup is that if you use overdrive distortion created by the amplifier, changing settings on the LXP-1 also affects the quantity and quality of your distortion. If you use a separate distortion box, you can get around this problem by connecting it before the LXP-1. If you prefer amplifier-generated distortion, try the setup shown on the next page.



**Warning!** Never connect speaker outputs from a guitar amp to the LXP-1. Doing so can cause serious damage which is not covered by your LXP-1's warranty. On some guitar amplifiers, it is very easy to accidentally use a speaker output instead of a direct or effects output. Be careful!

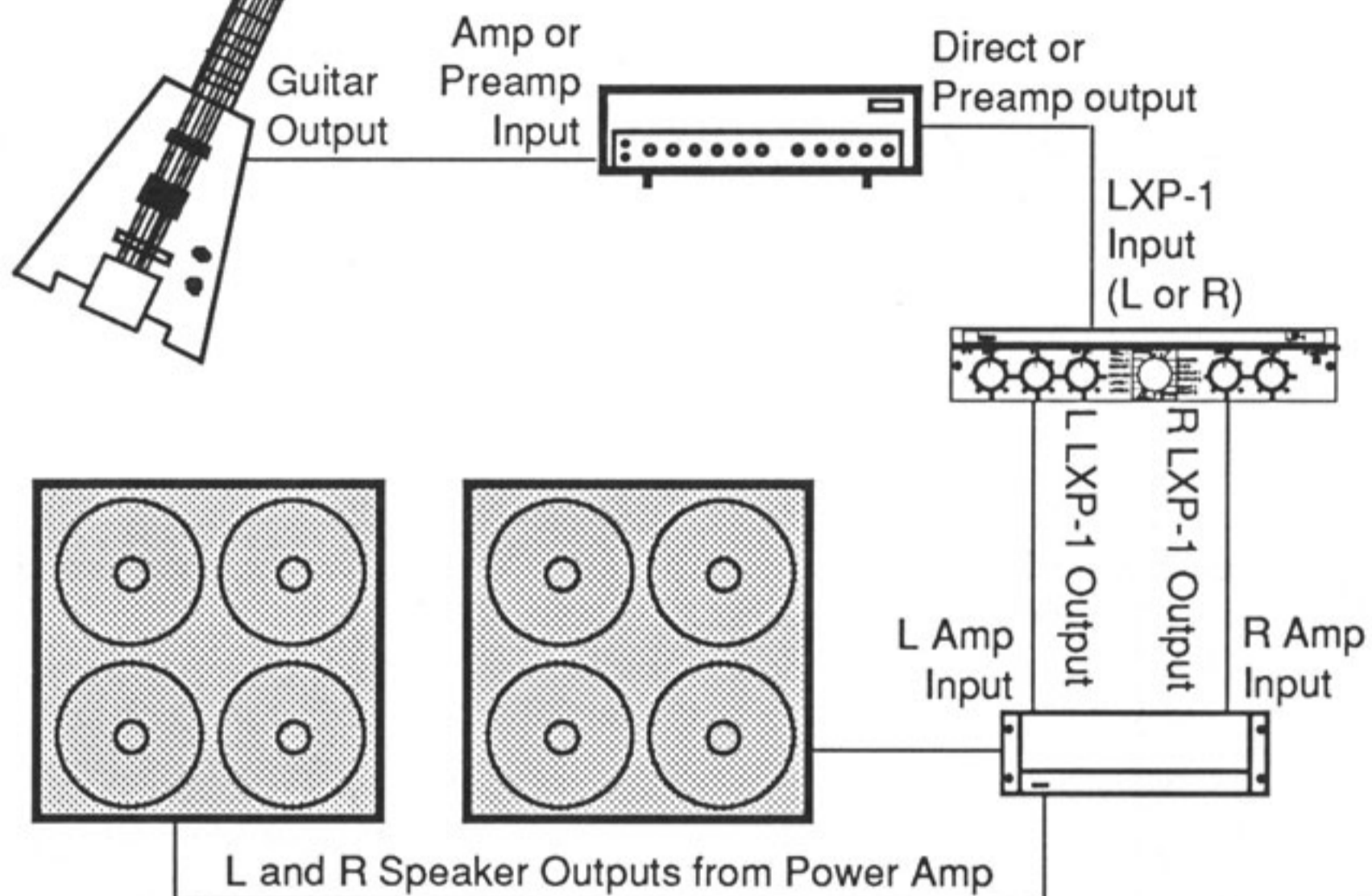

**Connection between instrument preamp and power amplifier(s)**

If you use overdrive distortion, it's usually better to create the overdrive *before* sending the signal to the LXP-1 (or just about any other effect, for that matter). Doing this ensures that the effects don't change the quantity and quality of your distortion. In this setup, you need a guitar preamplifier or a guitar amp with a direct output. Feed this signal to either of the LXP-1 inputs, and then on to a stereo power amp or a pair of guitar amps. (A few guitar amplifiers become unhappy if they are operated without speakers connected. Consult the amp's manufacturer for details.)

You can use the effects send and return connectors on a mono guitar amp to obtain similar results. Adjust the LXP-1 output level so that the amp produces the same output with the LXP-1 as it does without it.

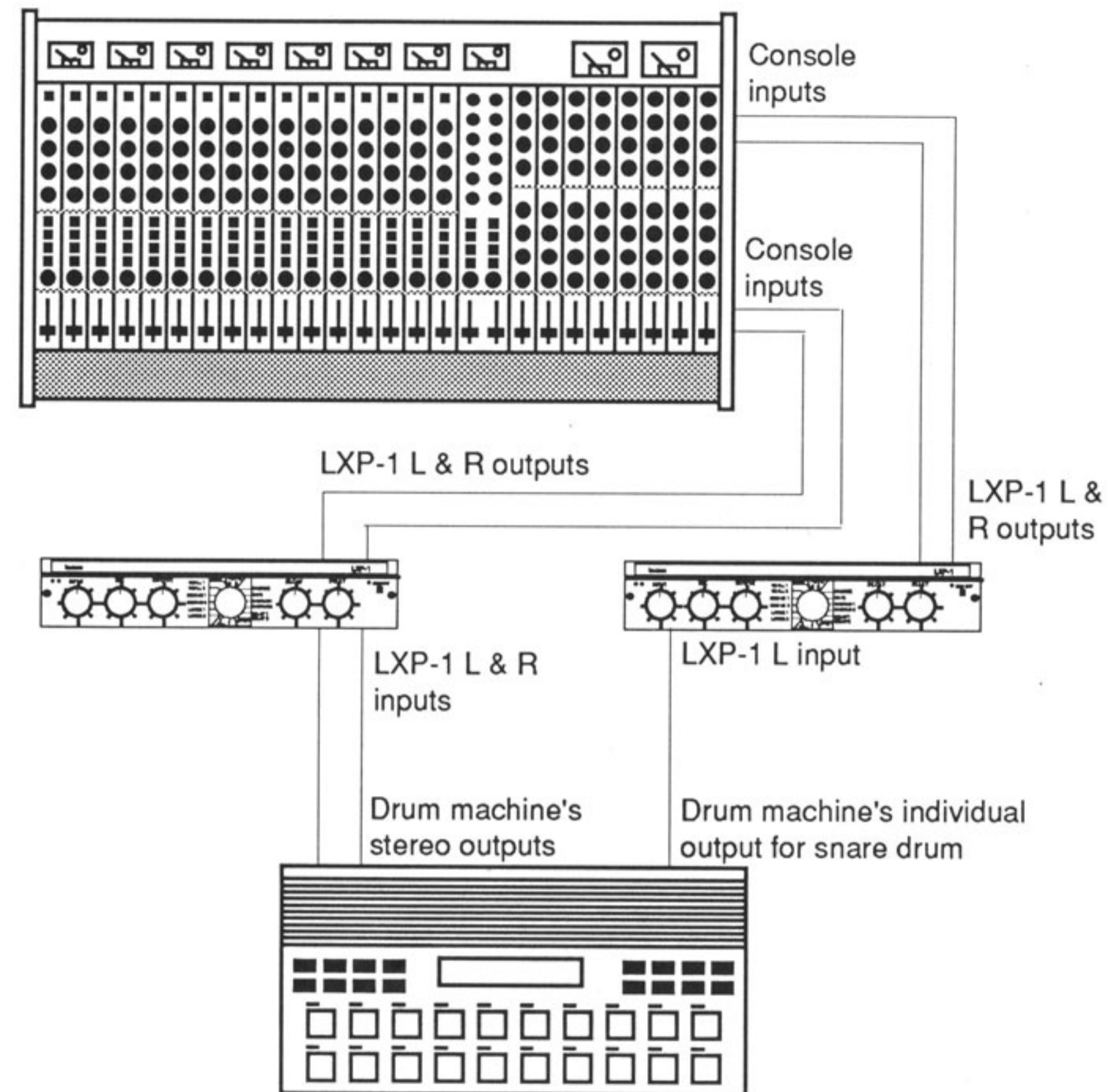

**Connection between drum machine and console**

Using two LXP-1 units between your drum machine and console can make your drum machine sound much more exciting, since it allows you to process the all-important snare drum separately from the rest of the mix. Make sure you remove the snare from the drum machine's main stereo mix. Try using PLATE D or B on the stereo mix, and GATE or INVERSE on the snare.

## 2. Operating the LXP-1

### Setting audio levels

The wide range of adjustment available with the LXP-1's INPUT and OUTPUT LEVEL controls allow it to be used with virtually any kind of equipment found in the studio or on the road.

To set audio levels:

1. Turn the LXP-1 INPUT and OUTPUT LEVEL controls all the way down (fully counterclockwise).
2. Set the instrument output, preamp output, or effects send that feeds the LXP-1 input(s) to a nominal level. With an instrument, this should be your loudest normal playing level; with a preamp output or console, adjust the output(s) or effects send(s) to produce the highest level possible with the least amount of noise. If the output you are using doesn't have a level control, don't worry about it!
3. While sending audio to the LXP-1, gradually turn up the INPUT LEVEL control until the green SIGNAL PRESENT LED lights. Continue to advance INPUT LEVEL until the red PEAK LED just flashes on the loudest peaks. If it flashes continuously, reduce INPUT LEVEL slightly. This ensures the best possible signal-to-noise ratio and dynamic range.

SIGNAL PRESENT  
LED should be lit

PEAK LED flashes on peaks;  
INPUT LEVEL should be set to the  
level where the PEAK LED flashes  
briefly on the loudest peaks only

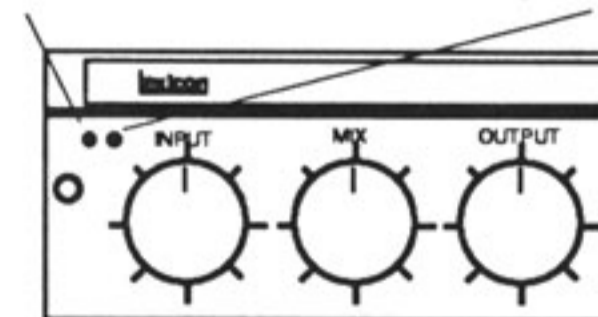

**Note:** If the PEAK LED flashes with no input present (i.e., during reverb decay or delay line feedback, it indicates processor overload is occurring.



- If the LXP-1 inputs are connected to a console effects send, and its outputs are connected to console channel strip inputs, set the console's input level trim and fader to a setting typically used for line level inputs. Then set the MIX control fully clockwise (100% effect) and gradually turn up the LXP-1 OUTPUT LEVEL control until the right amount of audio is present at the console.

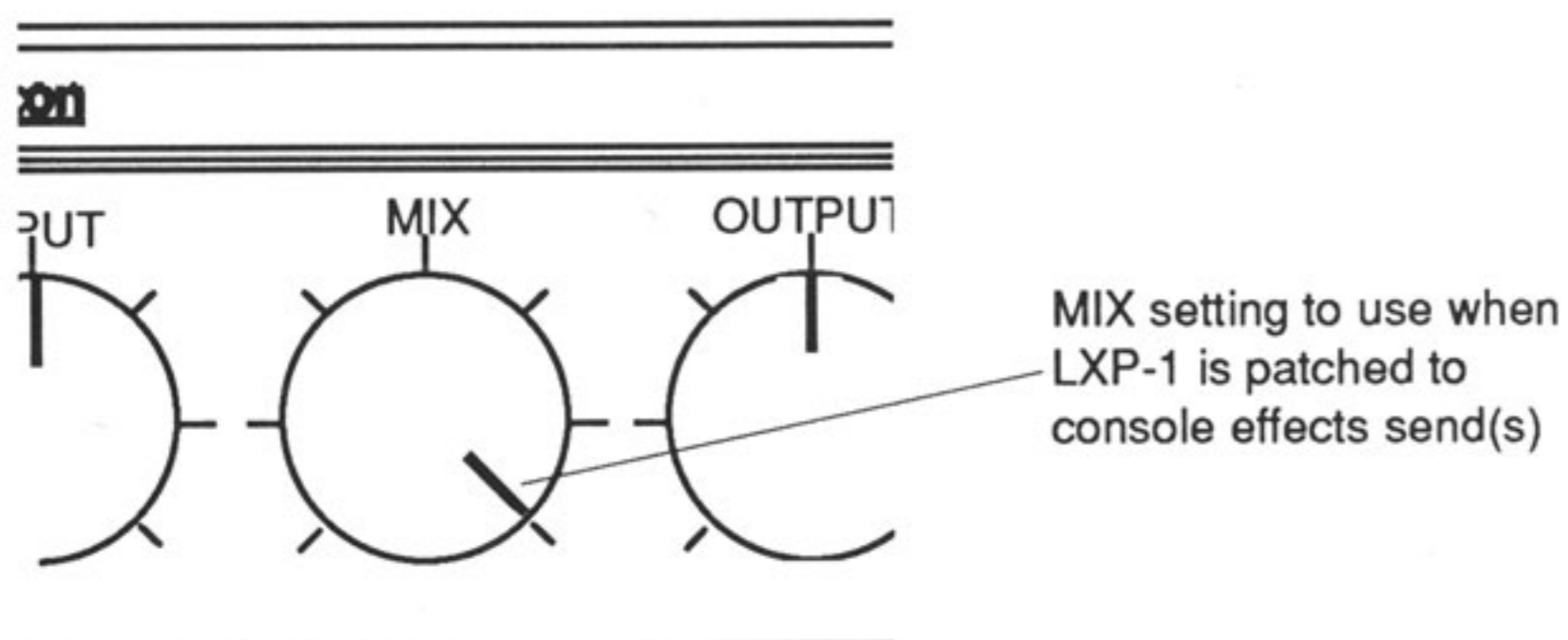

- If you are using an instrument amplifier or preamplifier, start with the LXP-1 MIX control straight up (50% effect). Then gradually increase the OUTPUT LEVEL control until the audio level heard from the amplifier is approximately the same as when the LXP-1 is not connected.

The best setting for MIX depends on which program you are using, and to a great extent, your personal taste; feel free to experiment.

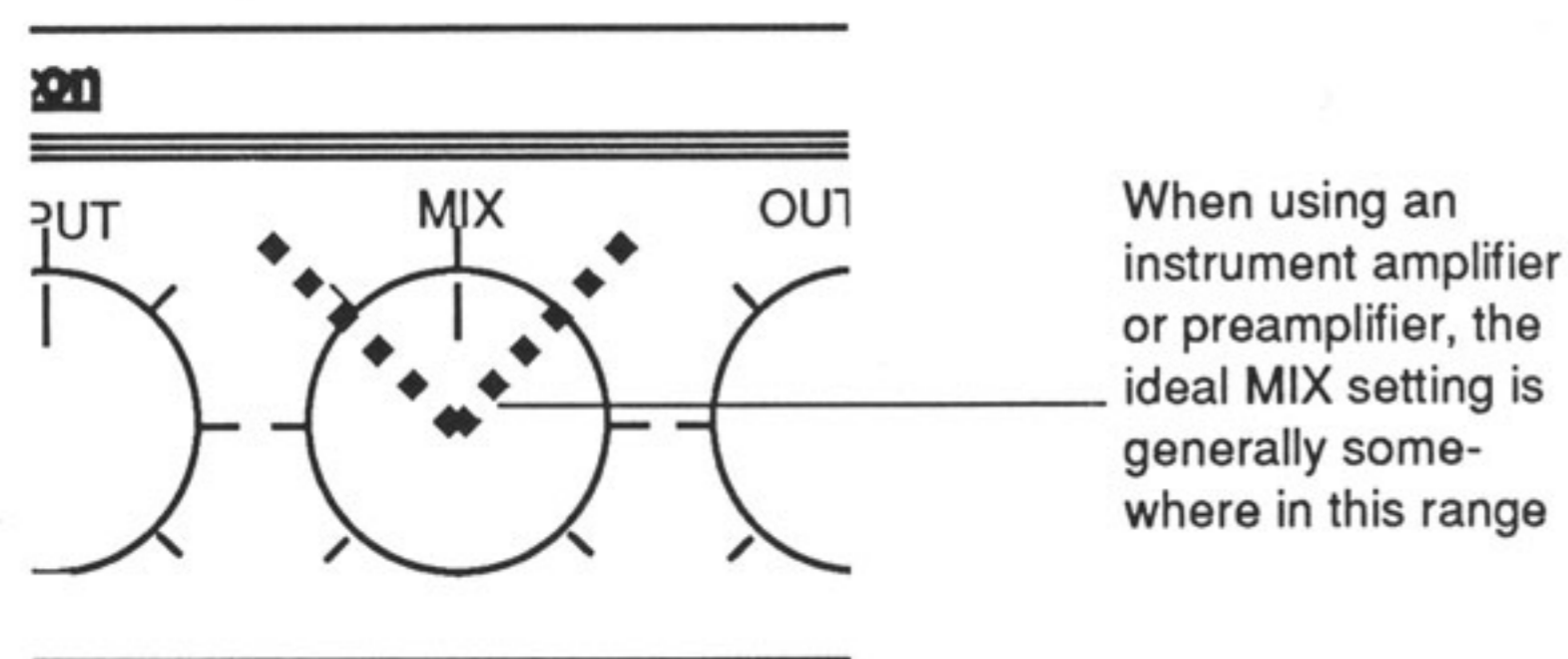

## DEFEAT switch operation

When an ON/OFF toggle footswitch (optional) is connected to the rear panel DEFEAT connector, pressing it removes the wet signal from the input to the signal processor. This allows any reverberation or echoes to decay naturally. Pressing the switch again restores the wet signal at the level set with the MIX control. If programs or parameters are changed while DEFEAT is active, the new settings will take effect when defeat is deactivated.

## Selecting LXP-1 preset programs

Any one of the LXP-1's 16 preset programs can be selected by turning the Program knob on the front panel until it points to the name of the preset that you want to use. The CHORUS 1 program is in use in the example shown below.

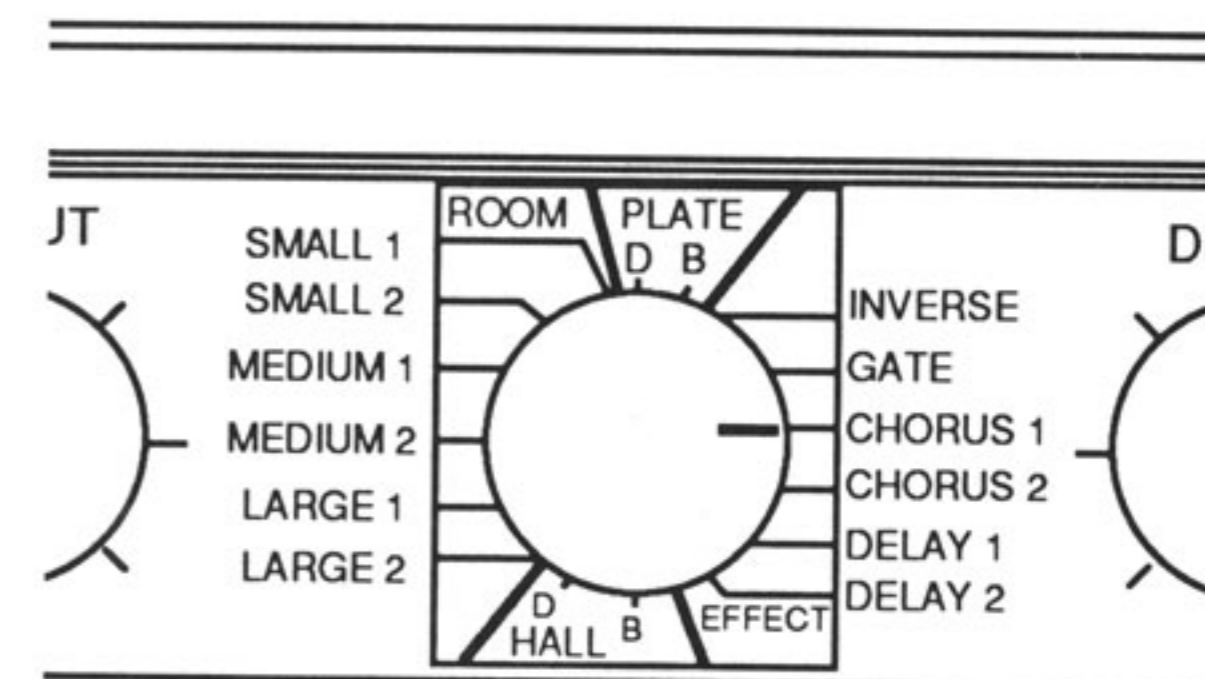

## Changing parameters

Each program has two variable parameters controlled with the front panel DECAY and DELAY controls. These parameters are used to tailor the sound of the LXP-1 to your specific requirements.

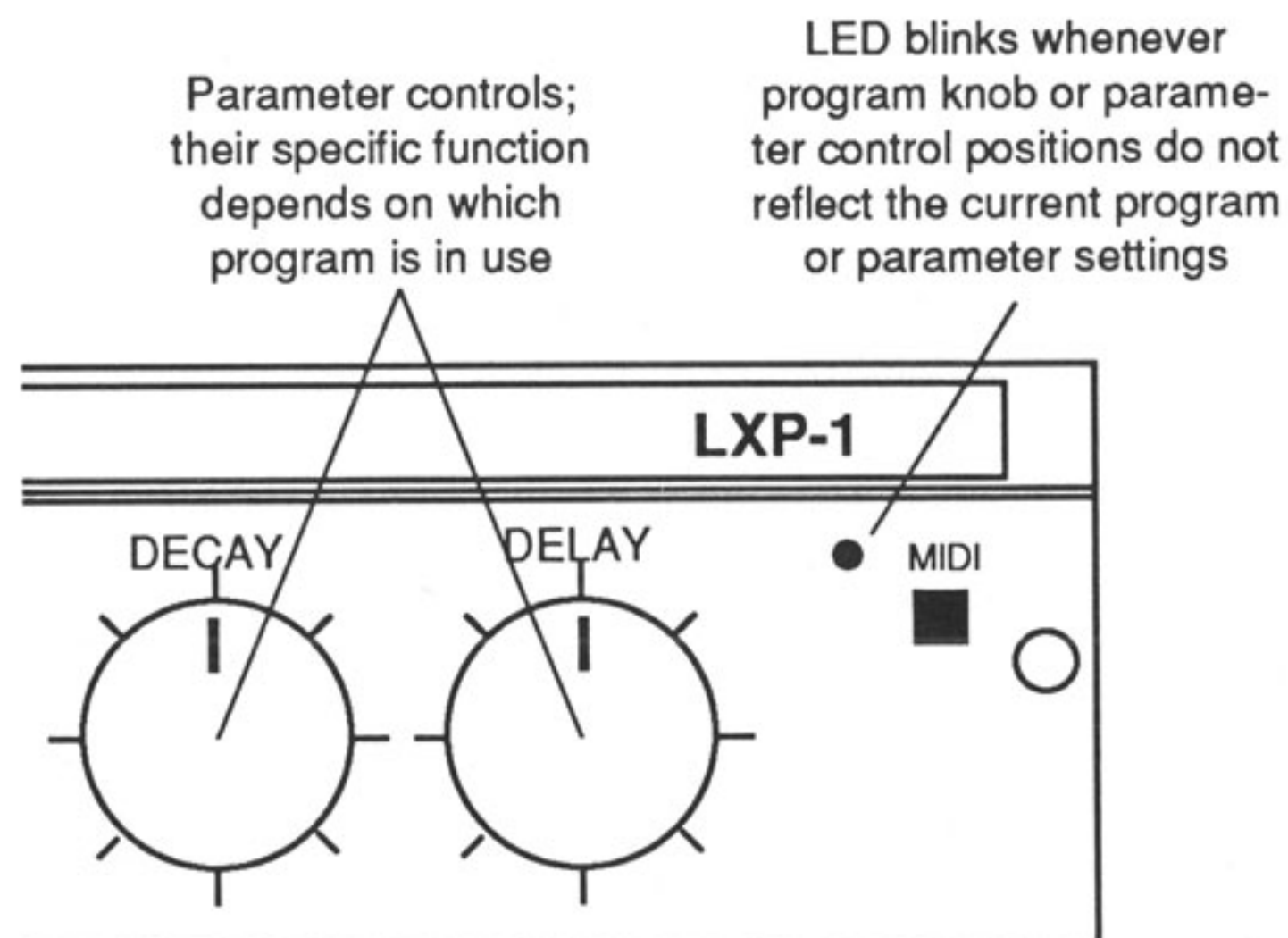

When you load a new program, the front-panel MIDI indicator blinks to let you know that the position of one or both of the parameter controls does not reflect its actual setting. As soon as you move a knob, the parameter snaps to the new setting you've selected. Once you've moved both parameter knobs, the knob positions accurately reflect the current setting, so the MIDI indicator stops blinking.

**Note:** For faster operation, the parameter controls have no mechanical stop to keep you from turning from the maximum directly to the minimum value, or vice versa. If the boundary between maximum and minimum is crossed, the value snaps over so that the knob position accurately reflects the current parameter value. The boundary is at the six o'clock (straight down) position.

If you select a different program after changing the parameters for the current program, the changes you made are lost, so that the next time you load the program, the original parameter values are restored. If you have a MIDI device which can send program change messages, the changes can be stored in a user register for future recall. See Chapter 3 for details.

## Descriptions of programs and parameters

There are four types of preset programs in the LXP-1:

- Halls and Rooms
- Plates
- Reverb effects
- Delay effects

The programs and their variable parameters are discussed below.

### Halls and Rooms

The eight hall and room presets range from large natural-sounding spaces with the spread, attack, and build of a concert hall to small rooms with sudden attacks and the coloration characteristic of small spaces.

The hall programs produce very clean reverberation, and are designed to add spaciousness, while leaving the source material unchanged. HALL B is a bright hall, and HALL D is a dark hall. In addition to general instrumental and vocal applications, halls are a good choice for giving separately recorded tracks the sense of belonging to the same performance.

The small rooms are tight and intimate, with a sound similar to a typical suburban American living room. SMALL 1 has a dark characteristic, while SMALL 2 is brighter. MEDIUM 1 and MEDIUM 2 are somewhat larger. LARGE 1 and LARGE 2 are the biggest rooms.

In the halls and rooms, the DECAY control sets the nominal reverberation decay time. The range is from 0.6 seconds to 8 seconds.

The DELAY control sets the amount of predelay (the length of time which elapses between input of signal and the onset of reverberation). The predelay range is between 0 and 246 milliseconds. With a MIDI controller patched to DELAY (as described in Chapter 4) predelay may be extended to 262 milliseconds.



The 16 DELAY control settings, specified in milliseconds, are listed below. These settings apply to all programs with standard predelay, including halls and rooms, plates, inverse room, and gated reverb.

0.0	16.4	32.8	49.2	69.5	81.9	98.3	115.0
131.0	148.0	164.0	180.0	197.0	213.0	229.0	246.0

### Plates

The plate programs mimic the sounds of metal plates, with high initial diffusion and a relatively bright, colored sound. Plates are usually the best choice for percussion. They are designed to be heard as part of the music, thickening and fattening the source material. PLATE B is a bright plate, and PLATE D is a dark plate.

The DECAY control sets the reverberation decay time. The range is from 0.6 seconds to 8 seconds. The DELAY control sets the amount of predelay. The predelay range is between 0 and 246 milliseconds.

### Reverb effects

There are two reverb effects in the LXP-1: GATE (gated reverb) and INVERSE (inverse room). GATE has a fairly constant sound with no decay until the reverberation is cut off abruptly. INVERSE is similar, except that the initial portion of the reverb envelope builds up before the reverberation cuts off abruptly.

INVERSE and GATE are both excellent choices for percussion — particularly snare drum.

The MIX setting is very important with these two programs, allowing you to set up anything from a subtle thickening or enhancement to a solid wall of reverb. In both programs, the DECAY control alters the Size of the program, therefore changing both time and density. The time ranges from about 150 milliseconds to 400 milliseconds. Changing DECAY will mute the effect, so be careful patching this control to MIDI. The DELAY control sets the amount of predelay, from 0 to 246 milliseconds.

### Delay effects

#### CHORUS 1

CHORUS 1 produces stereo flanging with two flanges that move in a fixed relationship with each other. Flange depth is set with the DELAY control, and feedback is set with the DECAY control. To enhance the spatial effect, a slight amount of delay is added to the left channel flange. If you want a single channel flange with no delay, use the LXP-1's right output, but leave a dummy cable in the left output to defeat the internal mixing of the two channels.

#### CHORUS 2

CHORUS 2 is a chromatic resonator with twelve resonators tuned to semitone intervals, giving the richness of resonating piano strings to percussion sounds. Source material with continuous tones (i.e., anything other than percussion) is made more spacious due to the hard left and right panning of alternate tones. A different amount of predelay is applied to each note to give a strummed effect to percussive sounds. The DECAY control serves as a master resonance range control for all twelve resonators. The DELAY control is a fine tuner for all twelve resonators, tuning  $\pm 1$  semitone in 1/8 semitone steps. The LXP-1 continuously shifts the resonators around their normal pitches to provide more interesting coloration. The rate and amount of this detuning is adjustable only via MIDI system exclusive.

#### DELAY 1

DELAY 1 is a six-voice chorus (three stereo pairs) with random chorusing of  $\pm 4$  milliseconds. The DECAY control sets positive feedback around the third voice pair from 0 to 94% ( $\pm 99\%$  available through MIDI System Exclusive).

The DELAY control sets the group base delay (Delay 1) for all three pairs. Under MIDI System Exclusive control, the second and third pairs (Delay 2, Delay 3) may be offset further. The Delay 1 parameter may be set as high



as 623 milliseconds (803 milliseconds under MIDI System Exclusive control). Delay parameters 2 and 3 may be extended up to 1 second more, as long as the total does not exceed 1.6 seconds. The 16 DELAY control settings, specified in milliseconds, are listed below.

0.0	8.2	16.4	24.6	32.8	49.2	57.3	73.7
98.4	123.0	164.0	213.0	279.0	367.0	475.0	623.0

## DELAY 2

DELAY 2 has four equally-spaced delay taps, alternated left and right. The DECAY control sets the amount of positive feedback generated around the longest tap from 0 to 94% ( $\pm 99\%$  available through MIDI System Exclusive). The DELAY control sets the delay time for the first delay tap, over a range from 0.9 to 252 milliseconds. Under MIDI control, the first tap may be extended to 305 milliseconds.

In order to provide the widest range of useful sounds, the length of the first tap grows exponentially, rather than linearly. The 16 DELAY control settings, specified in milliseconds, are listed below.

0.9	1.3	2.0	2.9	4.4	6.6	9.8	14.7
22.1	33.2	49.8	74.7	112.0	168.0	206.0	252.0

## Program table: Reverbs

Program name	Type	DECAY control function	DELAY control function	Parameter Value Range
Small 1	Room	Rvb Decay (RT60) 0.8 s 0.08 - 2.4 s	Predelay 16 ms 0.0 - 246 ms	Parameter Value Range
Small 2	Room	Rvb Decay (RT60) 1.2 s 0.12 - 2.5 s	Predelay 16 ms 0.0 - 246 ms	Parameter Value Range
Medium 1	Room	Rvb Decay (RT60) 1.2 s 0.3 - 4.0 s	Predelay 33 ms 0.0 - 246 ms	Parameter Value Range
Medium 2	Room	Rvb Decay (RT60) 1.6 s 0.4 - 8.0 s	Predelay 33 ms 0.0 - 246 ms	Parameter Value Range
Large 1	Room	Rvb Decay (RT60) 2.2 s 0.45 - 6.5 s	Predelay 33 ms 0.0 - 246 ms	Parameter Value Range
Large 2	Room	Rvb Decay (RT60) 2.4 s 0.55 - 8.5 s	Predelay 33 ms 0.0 - 246 ms	Parameter Value Range
Hall D	Hall	Rvb Decay (RT60) 1.6 s 0.6 - 8.0 s	Predelay 33 ms 0.0 - 246 ms	Parameter Value Range
Hall B	Hall	Rvb Decay (RT60) 2.6 s 0.65 - 9.0 s	Predelay 33 ms 0.0 - 246 ms	Parameter Value Range
Plate D	Plate	Rvb Decay (RT60) 1.8 s 0.4 - 6.0 s	Predelay 33 ms 0.0 - 246 ms	Parameter Value Range
Plate B	Plate	Rvb Decay (RT60) 1.7 s 0.25 - 6.5 s	Predelay 0 ms 0.0 - 246 ms	Parameter Value Range



## Program table: Reverb and delay effects

Program name	Type	DECAY control function	DELAY control function	Parameter Value Range
Inverse Room	Reverb Effect	Decay Time	Predelay	Parameter Value Range
		.3 s	0 ms	
Gate	Reverb Effect	Time	Predelay	Parameter Value Range
		.2 - .5 s	0 ms	
Chorus 1	Stereo Flange	Feedback	Depth	Parameter Value Range
		0%	4.1 ms	
Chorus 2	Chrom. Reson.	Resonance	Tuning	Parameter Value Range
		93%	0 semitones	
Delay 1	Delay/6-Voice Chorus	Feedback	Group Delay	Parameter Value Range
		0 - 94%	279 ms	
Delay 2	4-Tap Bounce Delay	Feedback	Delay Spacing	Parameter Value Range
		0 - 94%	9.8 ms	

## 3. MIDI operations

### Introduction

Without MIDI, the LXP-1 is an easy-to-use and flexible digital effects processor. With MIDI, it offers enough creative control to please the most demanding musician, producer, or engineer. We'll start with the simple applications, and work up to the more complex ones.

### Accessing LXP-1 registers

Up until now, you have used the front panel program selector knob to access the 16 preset programs. Any changes you made with the two parameter controls were lost as soon as you selected another program. However, you can use MIDI to store and recall up to 128 user-programmable registers. All you need is a device which can send MIDI program change messages, such as a MIDI-equipped synthesizer, master keyboard controller, foot controller, sequencer, or the Lexicon MRC remote control unit.

A typical MIDI setup is shown below. Connect the MIDI output of the controller to the MIDI input of the LXP-1, using a standard MIDI cable.

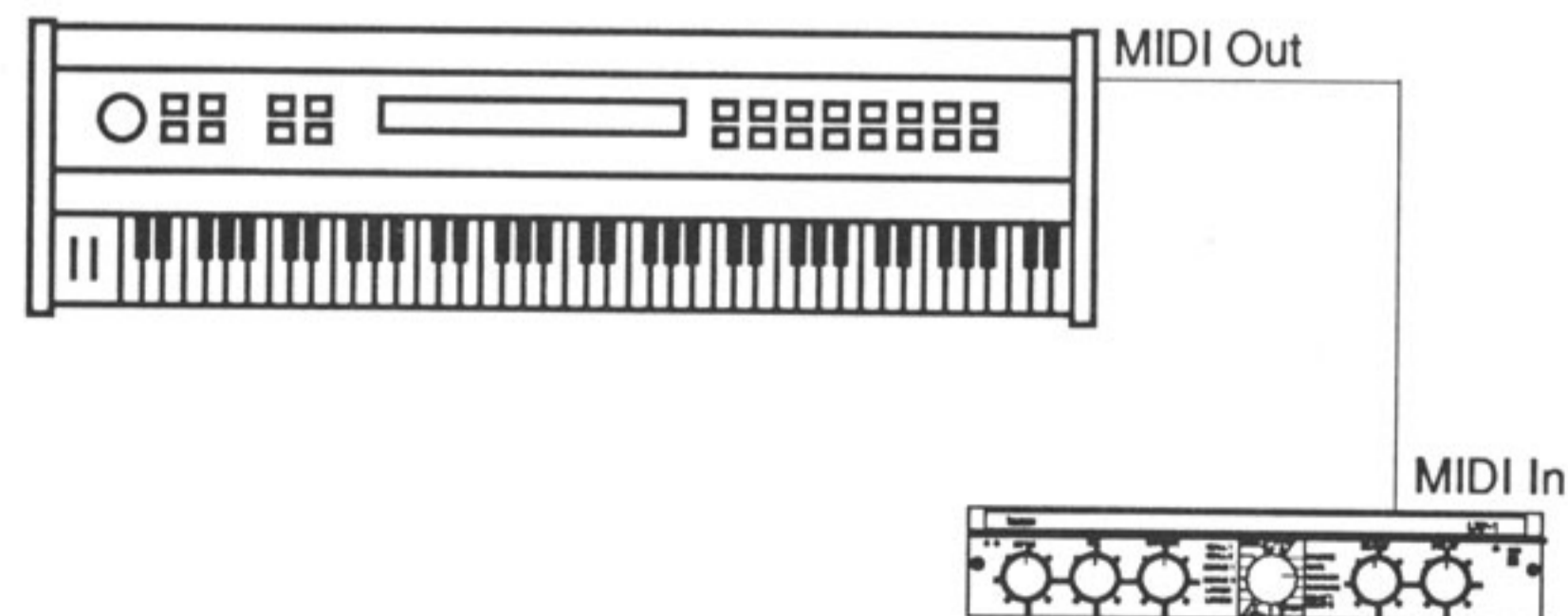



## Selecting a MIDI channel

Before you can use the LXP-1 with a MIDI controller, both units must be set to the same MIDI channel. To set the LXP-1 MIDI channel:

1. Set the controller you will be using (keyboard, foot controller, etc.) to any MIDI channel (1 through 16). The LXP-1 has no OMNI mode — it responds to only one channel at a time.
2. While holding down the MIDI button on the front panel of the LXP-1, send it any complete MIDI message from the controller. This might be a program change, a note on a keyboard, a sustain pedal, etc. The running status messages sent by some controllers will not cause a channel change, since these messages do not contain channel information. If you encounter difficulties with running status, send a note message followed by a pitch bend message. This will interrupt any running status.
3. Release the MIDI button. The LXP-1 sets itself to the channel you just used.

## Storing a register

After editing a preset program with the front panel parameter knobs, you can store the edited program in any of the 128 LXP-1 user registers (numbered 0 to 127):

1. Connect your MIDI controller and the LXP-1 and set them to the same MIDI channel as described above.
2. Hold down the MIDI button on the LXP-1 front panel.
3. While holding down the MIDI button, send a MIDI program change message from your MIDI controller. On most synthesizers, selecting a new voice (sound) accomplishes this. The LXP-1 stores the edited program in the register with the same number you sent it. For example, if you select voice number 23 on the synthesizer, the current program and parameter settings are stored in user register 23 of the LXP-1.
4. Release the MIDI button. The edited program is saved in the register number named in the program change message. The MIDI indicator flashes at a fast rate for about two seconds to indicate success.

5. If you store a register using a program change message on a different MIDI channel than the LXP-1 was set to previously, the LXP-1 stores the register and automatically resets itself to the new MIDI channel.

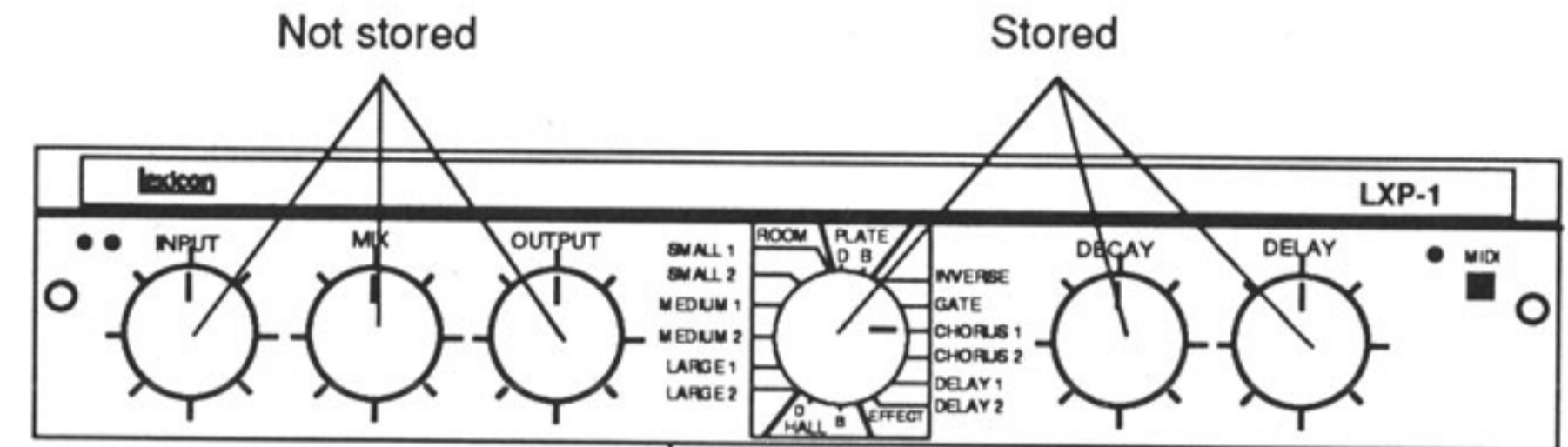

Rear panel Defeat switch status not stored

6. When you save a register, the selected program and the new values for the two parameter controls are stored, but the settings for the Input Level, Mix, Output Level, and the rear panel Defeat switch are not.
7. The LXP-1 does not perform any checking to see if a register is already in use before storing. When you store a register, always make sure that the location you choose doesn't contain anything you want to keep.

## Loading a register

To load a program from a register:

1. Connect your MIDI controller and the LXP-1, and set them to the same MIDI channel, as described previously.
2. Send a MIDI program change message (0-127) from the controller. The LXP-1 loads the register with the same number you sent it. For example, if you send program change number 23, the current program and parameter settings stored in user register 23 of the LXP-1 are loaded.



## Living with controller quirks

Some synthesizers and controllers (like the Korg DW-8000) cannot send the full range of MIDI program change messages (0-127). With them, you can't access all the registers in the LXP-1. Others, like the Yamaha KX-88, may appear to be able to send only 32, but actually have a bank mode that *does* let you send all 128 program change messages. If in doubt, see the manual for your controller.

How program changes are numbered can also lead to confusion. The first register in the LXP-1 is register number 0, corresponding to a MIDI program change 0 message. Many other manufacturers of MIDI equipment (like Oberheim) use this same numbering system. But others (like Yamaha) start numbering their programs with number 1. When using this equipment, there is always a one-digit offset between the program number shown on their display and the actual MIDI program change number they send. For example, if you load program number 1 on a KX-88 or a DX-7, it actually sends a MIDI program change 0 message, causing register 0 to load on the LXP-1. This may seem confusing at first, but you'll soon get the hang of it!

## Using Dynamic MIDI®

Some extremely useful effects can be created when the LXP-1's variable parameters are controlled remotely in real time. Almost all of the controllers found on a MIDI keyboard or foot controller (pitch benders, mod wheels, sliders, switches, breath controllers, foot pedals, and footswitches) can be used to adjust the LXP-1's parameters. We refer to this real time remote control capability as Dynamic MIDI®.

To use Dynamic MIDI®, you "patch" a MIDI controller to the parameter you want to control. You can patch a separate controller to each parameter, or you can patch a single controller to control both parameters simultaneously. Two patches can be stored in each register using the front panel controls. Two more can be stored using MIDI system exclusive.

### Creating a Dynamic MIDI® patch

1. Connect your MIDI controller and the LXP-1, and set them to the same MIDI channel.

2. Select the LXP-1 preset or register you want to assign patches to. For this example, use the LARGE 2 ROOM preset program.
3. Press and hold down the MIDI button on the front panel.
4. While continuing to hold down the MIDI button, move the MIDI controller you want to patch. You don't have to move the control through its entire range — just move it enough so the LXP-1 can identify what controller you are using. For example, if you are patching a foot pedal plugged into a keyboard or foot controller, press the foot pedal down a bit and then back again.
5. While still holding down the MIDI button, move the LXP-1 parameter control you wish to assign (use the DECAY parameter for this example). Again, you don't have to move the control through its entire range. Move it just a click or two in either direction. This identifies the parameter to be assigned to the MIDI controller you specified in step 4.
6. While still holding down the MIDI button, set the LXP-1 parameter control to the scaling you want. (Scaling sets the range of effectiveness for the MIDI controller.) For now, set the parameter control to its highest value — just counterclockwise of the straight down (6 o'clock) position. *Release the MIDI button.*
7. Now set the parameter control to the setting you want to use as the base setting (the setting used when the MIDI controller is all the way down). If you want access to the full range of parameter adjustment, set the parameter control to its lowest value — just clockwise of the 6 o'clock position.
8. Move the MIDI controller through its range while sending audio through the LXP-1. With the controller all the way down, the decay time should be very short. As you move the controller up, the decay time should become progressively longer.
9. To save the patch in a register, use the procedure for storing a register described earlier in this chapter. Now, whenever you recall that register, the patch(es) you stored in it are recalled at the same time.



## The LXP-1 and MIDI System Exclusive data

When using the LXP-1 with a device programmed to transmit the LXP-1's system exclusive data (such as Lexicon's MRC MIDI Remote Controller), a whole new world of flexibility opens up. The MRC allows you to edit up to eight parameters for each program for much greater creative potential when tailoring sounds for your own applications. Registers can be stored in the MRC, making it a powerful control center for systems which include one or more LXP-1's. For complete information about using the LXP-1 and the MRC together, see the *MRC Owner's Manual*.

Many of these functions may also be available in software packages for popular personal computer systems. See your Lexicon dealer for details.

## 4. MIDI Sys Ex implementation data

The information contained in this chapter is intended to assist experienced programmers in developing software for use with the LXP-1.

### 1) Receive

#### A. Active Setup Data

Byte	Value	Description
1	F0 (hex)	System Exclusive
2	06	Lexicon ID
3	02	LXP-1 ID
4	0000 nnnn(bin)	n = midi channel 0-15
5	38 (hex)	packed data byte count (=56; 49 unpkd)
6	0vvv vvv(bin)	data in 8/7 packed format (Section 4,6)
	.	
	.	
	.	
61	0vvv vvv	
62	0sss ssss	sumcheck of data bytes (sum done on the bytes in packed format)
63	F7 (hex)	End of sysex message



**B. Stored (Single Register) Data**

Byte	Value	Description
1	F0 (hex)	System Exclusive
2	06	Lexicon ID
3	02	LXP-1 ID
4	0001 nnnn(bin)	n = midi channel 0-15
5	0ppp pppp	p = register number 0 - 127
6	38 (hex)	packed data byte count (=56; 49 unpkd)
7	0vvv vvv	data in 8/7 packed format (Section 4,6)
.	.	.
.	.	.
62	0vvv vvv	
63	0sss ssss	sumcheck of data bytes (sum done on the bytes in packed format)
64	F7 (hex)	End of sysex message

**C. Packed Parameter Adjust**

**Note:** All parameter change messages require that a full 16 bits be sent for proper interpretation. If the destination parameter is only 8 bits wide, the most significant transmitted byte should be 0.

Byte	Value	Description
1	F0 (hex)	System Exclusive
2	06	Lexicon ID
3	02	LXP-1 ID
4	0010 nnnn(bin)	n = midi channel 0-15
5	0ppp pppp	p = parameter number 0 - 127
6	0vvv vvv	data in 8/7 packed format (Section 3,4)
7	0vvv vvv	
8	0vvv vvv	
9	F7 (hex)	End of sysex message

**D. Requests**

Byte	Value	Description
1	F0 (hex)	System Exclusive
2	06	Lexicon ID
3	02	LXP-1 ID
4	0011 nnnn(bin)	n = midi channel 0-15
5	0eee eeee	e = event code: 60h = active setup data 61h = one register 62h = packed param data 64h = all registers 65h = nibble param data
6	0ppp pppp	p = register number 0 - 127 for e = 61 = param number for e = 62, e = 65 above; else present but ignored
7	F7 (hex)	End of sysex message



**E. All Registers Data**

Byte	Value	Description
1	F0 (hex)	System Exclusive
2	06	Lexicon ID
3	02	LXP-1 ID
4	0100 nnnn(bin)	n = midi channel 0-15
5	38 (hi) (hex)	count of packed data bytes
6	00 (lo)	(56*128=7168=0x1c00 = 3800 in 7-bit)
7	0vvv vvvv(bin)	data in 8/7 packed format (Section 4,6)
.	.	.
.	.	.
7174	0vvv vvvv	
7175	0sss ssss	sumcheck of data bytes (sum done on the bytes in packed format)
7176	F7 (hex)	End of sysex message

**F. Nibblized Parameter Adjust**

**Note:** All parameter change messages require that a full 16 bits be sent for proper interpretation. If the destination parameter is only 8 bits wide, the most significant transmitted byte should be 0.

Byte	Value	Description
1	F0 (hex)	System Exclusive
2	06	Lexicon ID
3	02	LXP-1 ID
4	0101 nnnn(bin)	n = midi channel 0-15
5	0ppp pppp	p = parameter number 0 - 127
6	0000 dddd(hi)	d = 16-bit data sent in nibbles
7	0000 dddd	
8	0000 dddd	
9	0000 dddd(lo)	
10	F7 (hex)	End of sysex message

**G. Events**

Byte	Value	Description
1	F0 (hex)	System Exclusive
2	06	Lexicon ID
3	02	LXP-1 ID
4	0110 nnnn(bin)	n = midi channel 0-15
5	0eee eeee	e = event code: 70h = store register 71h = recall register
6	0ppp pppp	p = register number 0 - 127
7	F7 (hex)	End of sysex message

## 2) Transmitted

Sent in response to receipt of system exclusive request message. Transmitted data is identical in format to received data specified in sections A, B, C, E, F, and G in Section 1 above. When transmitting an 8-bit parameter value, the hi byte is padded with zeros.

When a front panel knob is turned the LXP will transmit a packed parameter change message reflecting the position to which the knob was turned (see section 1C above for the format). The transmitted parameter number will be Parameter 0 for a Decay knob change, Parameter 1 for a Delay knob change, and Parameter 64 (setup number) for a Program knob change. Two LXP-1's can be slaved together by connecting the MIDI OUT from one unit to the MIDI IN of the other. Any control change on the "master" unit will also be performed on the "slave."

The LXP has only one MIDI "output" jack. It is set up at the factory to perform the MIDI THRU function. There is an internal jumper that must be changed to make the jack perform the MIDI OUT function. The data transmissions described here are only available with the jack configured as a MIDI OUT.

## 3) Parameter Definitions

All parameters are accessible by Parameter Change messages. There are two major parameter classifications. These are Program parameters and System parameters.

### A. Program Parameters

The values of these parameters will, in general, change when each new setup is loaded. Typically this means that the values of these parameters are stored as part of a setup. Similarly, when a new setup is retrieved all its stored program parameters are retrieved with it. These parameters come in both 16-bit and 8-bit sizes. The 16-bit parameters which control various audio functions are numbered from 0 to 9; the rest are 8-bit parameters and are numbered from 32 to 59. MIDI Parameter change messages assume a 16-bit parameter size; when transmitting a value for an 8-bit parameter a full 16-bit number must be transmitted (pad the most significant byte with zeros).

Parameter 0 (the first of the 16-bit parameters) is driven directly by the Decay knob; Parameter 1 is driven by the Delay knob. A sysex change of one of these parameters will over-write any existing value due to knob change (or previous sysex change), and vice-versa (a knob change will over-write any value due to a previous sysex change, etc.).

Parameter 10 (Input Level) is a special case. It is treated similarly to the other 16-bit audio control parameters (numbers 0 through 9) with the exception that it is not stored as part of a register. Whenever a new setup is recalled the value of input level is always set to maximum.

The patch offsets are re-calculated continuously from the patch source and scale information. Therefore their values are also not stored when registers are saved. When a new setup is recalled the new patch offsets are re-calculated shortly thereafter. The patch offset parameters are numbered 60 through 63 and are also 16 bits wide.

### B. System Parameters

System parameters are 8 bits wide. Their meanings are not redefined for each setup. When modified through a parameter change message the full 16-bit message must be sent (pad the ms byte with zeros).

There are only two system parameters. The value of Setup number, parameter 64, controls which setup is running on the machine. Setups 0-127 are registers 0-127, while setups 128-144 are presets 0-15 (these are equivalent to turning the front panel Program knob to positions 0-15).

The value of Program ID (parameter 65) controls which microcode algorithm is currently running. Each preset or register has an associated program ID. The program ID associated with each preset is given in the following table:

<u>Preset</u>	<u>Pgm ID</u>
Rooms and Halls	1
Plates	2
Chorus 1 (Flange)	3
Delay 2 (4-tap)	4
Chorus 2 (resonator)	5
Inverse	6
Gate	7
Delay 1	8



**C. Parameter map**

Param	Size	Data
0	16 bit	Decay knob value
1	16 bit	Delay knob value
2-9	16 bit	Other microcode parameters
*10	16 bit	Processor Input Level
32-47	8-bit	Name (16 characters)
48-51	8-bit	MIDI patch sources 0 - 127 (see Table 1)
52-55	8-bit	MIDI patch dest, ucode param nums 0-9 (Sec. 5)
56-59	8-bit	MIDI scale factors, -127 to +127, 2's compl
*60-63	16 bit	MIDI patch offsets
*64	8-bit	Setup number
*65	8-bit	Program ID

\*Not stored during register save.

The Midi patch offset values are generated internally by multiplying the value of the specified patch source by the patch scale value. This offset is added to the stored value of the specified destination parameter. This sum of the offset and base value is the value used by the audio processor and the parameter transmit routines. The programmer should be aware that the offset values are continually updated internally; therefore if the programmer changes the offset value externally it will be overwritten internally shortly thereafter. The offset parameters are most useful when read to determine the midi patch contribution to the parameter values transmitted by the LXP.

**Note:** When the LXP receives a parameter change, the received value is used as the new base parameter value. When the LXP transmits a parameter value, however, the value transmitted is the base parameter value plus the MIDI patch offset.

The 16-bit microcode parameters (parameters 0 - 10) have values that are centered about 0x8000, and have a maximum range of 0x3FFF. Therefore unipolar parameters may take on values between 0x8000 (lowest value) and 0xBFFF (highest value), while bipolar parameters may take on values between 0x4000 (most negative) to 0xBFFF (most positive). Any value received outside these limits will be interpreted as the closest possible legal value.

Table 1 - MIDI Patch Sources

Control Number	Function
0 - 31	Continuous controller 0 - 31
32 - 63	Switches 0 - 31
64	Last note played
65	Last note's velocity
66	Channel aftertouch value
67	Pitch bend value
68	MIDI tempo value

**4) Data Packing Format**

The packing algorithm takes as input 7 'normal' 8-bit bytes and packs them into 8 7-bit bytes with the msb of each set to zero. The receiving routine reverses the process. The pack/unpack format is as follows:

Unpacked data:

```

byte 0:  a7 a6 a5 a4 a3 a2 a1 a0 (least significant)
byte 1:  b7 b6 b5 b4 b3 b2 b1 b0
byte 2:  c7 c6 c5 c4 c3 c2 c1 c0
byte 3:  d7 d6 d5 d4 d3 d2 d1 d0
byte 4:  e7 e6 e5 e4 e3 e2 e1 e0
byte 5:  f7 f6 f5 f4 f3 f2 f1 f0
byte 6:  g7 g6 g5 g4 g3 g2 g1 g0 (most significant)

```

## Packed output:

```

byte 0:  0 g7 f7 e7 d7 c7 b7 a7 (earliest transmitted)
byte 1:  0 a6 a5 a4 a3 a2 a1 a0
byte 2:  0 b6 b5 b4 b3 b2 b1 b0
byte 3:  0 c6 c5 c4 c3 c2 c1 c0
byte 4:  0 d6 d5 d4 d3 d2 d1 d0
byte 5:  0 e6 e5 e4 e3 e2 e1 e0
byte 6:  0 f6 f5 f4 f3 f2 f1 f0
byte 7:  0 g6 g5 g4 g3 g2 g1 g0 (latest transmitted)

```

A large quantity of data is handled by sending as many packets as necessary until the data is transmitted (least significant data sent first). It may sometimes be necessary to send a packet of less than seven bytes. In this case only those bytes are sent, preceded by the MSB byte with the active MSBs right-justified. For example, to send a 16-bit word, the format is as follows:

## Unpacked data:

```

byte 0:  a7 a6 a5 a4 a3 a2 a1 a0 (least significant)
byte 1:  b7 b6 b5 b4 b3 b2 b1 b0 (most significant)

```

## Packed output:

```

byte 0:  0 0 0 0 0 0 b7 a7
byte 1:  0 a6 a5 a4 a3 a2 a1 a0
byte 2:  0 b6 b5 b4 b3 b2 b1 b0

```

## 5) LXP Parameter Definitions

All parameters in the LXP have a fixed MIDI control range: A transmitted value of 0x8000 is considered the zero point for unipolar parameters and delays. 0xBFFF is always the maximum value.

Bipolar parameters such as feedback interpret values from 0x4000 (most negative) to 0x7FFF (least negative) as negative values.

Bass Multiply uses a range of 0x4000 to 0xBFFF where 0x4000 is the minimum and 0xBFFF is the maximum. A value of 0x8000 corresponds to a Bass Multiplication of one.

Coefficient varying parameters and other special controls obviously lack the resolution implied by this range. It would be clever if the controlling device only transmitted new values which would actually have an effect. The resolution of the LXP-1, in steps over the entire range of the parameter, is included for each parameter.

### A. REVERBS:

Halls and Rooms, pgm ID = 1.  
Plates, pgm ID = 2.

Parameter	LXP Param Num	Range	Num of Steps
Rvb Mid Decay	0	Uni	16
Pre-Delay	1	Uni	8192
Effects Level	2	Uni	256
Bass Multiply	3	Bi	32
Hi Freq Cut	4	Uni	16
Size	5	Uni	64
PreDly Fdbk	6	Bi	512
Diffusion	7	Uni	256

### B. CHORUS 1

Stereo Flange, pgm ID = 3.

Parameter	LXP Param Num	Range	Num of Steps
Negative Feedback	0	Uni	256
Depth *	1	Uni	256
Effects Level	2	Uni	256
Right Feedback	3	Bi	512
Right Delay	4	Uni	128
Shape	5	Uni	8
Left Feedback	6	Bi	512
Left Delay	7	Uni	128
Rate	8	Uni	16

\* A flange depth value of less than 8 samples, .25 msec, xmit val <= 0x8200 is not installed.



**B. CHORUS 1**, cont'd.

Delay xmit values above 0xBD00 are limited to 32000 samples, 1 second. LXP-1 Resolution of 128 reflects that machine screens the 1 second delay range to 8 msec intervals.

**C. DELAY 2** 4 tap bounce delay, pgm ID = 4.

Parameter	LXP Param Num	Range	Num of Steps
Positive Feedback	0	Uni	256
Ganged Delay	1	Uni	256
Effects Level	2	Uni	256
Feedback	3	Bi	512
Left Delay	4	Uni	256
Right Delay	5	Uni	256
Hi Freq Cut	7	Uni	16
Diffusion	8	Uni	256

**D. CHORUS 2** Chromatic Resonator, pgm ID = 5.

Parameter	LXP Param Num	Range	Num of Steps
Effects Level	2	Uni	256
Pre-Delay	3	Uni	256
Lo Freq Cut	4	Uni	256
Shimmer	5	Uni	16
Mstr Resonance	6	Bi	64
Richness	7	Uni	16
Slope	8	Uni	32
Tuning	9	Bi	128

**E. INVERSE ROOM** pgm ID = 6.

Parameter	LXP Param Num	Range	Num of Steps
Size	0	Uni	32
Effects Level	2	Uni	256
Hi Freq Cut	4	Uni	16
Slope	5	Uni	32
PreDly Fdbk	6	Bi	512
Diffusion	7	Uni	256
Pre-Delay	8	Uni	8192

**F. GATED REVERB** pgm ID = 7.

Parameter	LXP Param Num	Range	Num of Steps
Gate Time	0	Uni	32
Effects Level	2	Uni	256
Hi Freq Cut	4	Uni	16
Slope	5	Uni	16
PreDly Fdbk	6	Bi	512
Diffusion	7	Uni	256
Pre-Delay	8	Uni	8192

**G. DELAY 1** 6 Voice Chorus & Echo, pgm ID = 8.

Parameter	LXP Param Num	Range	Num of Steps
Group Delay	1	Uni	256
Effects Level	2	Uni	256
High Cut	3	Uni	16
Delay 2 Spread	4	Uni	128
Delay 3 Spread	5	Uni	128
Delay 3 Fdbk	6	Bi	512
Diffusion	7	Uni	256
Rate	8	Uni	16

## 6) Data Dump Contents

The Active Setup Data dump and Single Parameter Data dump have identical data arrangements. The tables below show the order in which the bytes are sent. The data here is shown in unpacked (8-bit) format (before it is packed into 7-bit format).

Data Byte	Data Size	Data Description
0	1-byte	Program (algorithm) ID
1,2	2-byte	RTime knob value
3,4	2-byte	PDelay knob value
5-20	2-byte	Other microcode parameters (exc Input Level)
21-36	1-byte	Name (16 characters)
37-40	1-byte	Midi patch sources 0 - 127 (see Table 1)
41-44	1-byte	Midi patch dest, ucode param nums 0-9 (Sec. 5)
45-48	1-byte	Midi scale factors, -127 to +127, 2's compl

49 bytes total unpacked, 56 bytes packed.

The All Registers Dump format is identical, with the exception that all 128 registers are sent in series in one SysEx message for a total length of  $128 * 56 = 7168$  packed data bytes (not counting header bytes, etc). Register 0 is sent first; register 127 is sent last.

## 7. Common Parameters

All of the parameters below are accessible by MIDI SysEx. Those parameters on the front panel knobs can easily be controlled by Dynamic MIDI.

### A. Effects Level

Parameter Number and Usage:	2 All programs	MIDI
Range:	0 to 100%	
Internal Resolution:	256 steps	
Function:	Sets final effects processor output level, prior to mix Always set to 100% in factory presets Intended for fine-tuning relative balance between user's registers.	

### B. High Frequency Cut

Parameter Number and Usage:	3 Reverbs	MIDI
	3 Delay 1 (6-voice Chorus)	MIDI
	7 Delay 2 (4 Tap Bounce)	MIDI
	4 Gate, Inverse	MIDI
Range:	321 Hz to 13.8 kHz	
Internal Resolution:	16 steps	
Function:	Sets high frequency roll off	

### C. Pre-Delay Feedback

Parameter Number and Usage:	6 Reverbs, Gate, Inverse	MIDI
Range:	-99% to +99%	
Internal Resolution:	512 steps	
Function:	Provides feedback effects around pre-delay loop. Up to 94% positive only from front panel DECAY knob, full range negative and positive under MIDI	



**D. Diffusion**

Parameter Number and Usage: 7 Reverbs, Delay 1, Gate, Inverse MIDI  
 8 Delay 2 MIDI  
 Range: 0 to 100 arbitrary units  
 Internal Resolution: 256  
 Function: Softens the attack of percussive sounds

**E. Predelay**

Parameter Number and Usage: 1 Reverbs DELAY KNOB MIDI  
 8 Gate, Inverse DELAY KNOB MIDI  
 Range: 0 to 8191 samples = 262 msec via MIDI  
 0 to 7680 samples = 246 msec via DELAY  
 KNOB  
 Internal Resolution: 4096 steps, 2 samples each, via MIDI  
 Function: Delays the onset of effects

**8. Specific Parameters for Reverb****A. Reverb Time**

Parameter Number and Usage: 0 Reverbs DECAY KNOB MIDI  
 Range: 0.6 secs to 9 secs, typical, Bright Hall  
 Internal Resolution: 16 steps  
 Function: Sets overall decay of sound in reverberator

**B. Bass Multiply**

Parameter Number and Usage: 3 Reverbs MIDI  
 Range: 0.3 to 2.5 nominal  
 Internal Resolution: 32 steps  
 Function: Scales reverberation time below 500 Hz in Reverbs

**C. Size**

Parameter Number and Usage: 5 Reverbs MIDI  
 Range: 8 Meters to 71 Meters  
 Internal Resolution: 64 steps  
 Function: Sets apparent size of reverberant space

**9. Specific Parameters for Gate****A. Gate Time**

Parameter Number and Usage: 0 DECAY KNOB MIDI  
 Range: 150 msec to 390 msec  
 Internal Resolution: 32 steps  
 Function: Adjusts the perceived length of gated sound  
 Since it is actually changing the size, it also subtly changes the timbre

**B. Slope**

Parameter Number and Usage: 5 MIDI  
 Range: 1 to 16  
 Internal Resolution: 16 steps  
 Function: Adjusts the slope of decay  
 Normally preset to maximum, slope is flat

**10. Specific Parameters for Inverse****A. Size**

Parameter Number and Usage: 0 DECAY KNOB MIDI  
 Range: 1 to 32  
 Internal Resolution: 32 steps  
 Function: Adjusts the perceived length of inverse effect  
 Since it is actually changing the size, it also subtly changes the timbre

**B. Slope**

Parameter Number and Usage: 5 MIDI  
 Range: 1 to 16  
 Internal Resolution: 16 steps  
 Function: Adjusts the slope of the inverse buildup  
 Normally preset to maximum

**11. Specific Parameters for Stereo Flange**

**A. Negative Feedback** 0 DECAY KNOB MIDI  
 Ganged negative feedback around flange depth, 0 to 99%  
 Slightly more feedback is applied to the left channel  
 Drives params #3 and #6 below, and overrides previously set relations between them  
 Available as MIDI parameter #0

**B. Flange Depth**

Parameter Number and Usage: 1 DELAY KNOB MIDI  
 Range: 0.25 msec to 8 msec  
 Internal Resolution: 124 steps of 6.25 microseconds  
 Function: Adjusts bass quality and speed of flange by setting limit of flange notch travel

**C. Delay**

Parameter Number and Usage: 7 Left MIDI  
 4 Right MIDI  
 Range: 0 to 1 sec  
 Internal Resolution: 8 millisecond increments  
 Function: Independent predelays on left and right channel flange

**D. Feedback**

Parameter Number and Usage: 6 Left MIDI  
 3 Right MIDI  
 Range: -99% to +99%  
 Internal Resolution: 512 steps  
 Function: Independent feedback around delay and flange for each channel

**E. Rate**

Parameter Number and Usage: 8 MIDI  
 Range: 0 to 15  
 Internal Resolution: 32 steps  
 First major step from 0 to 1 is further subdivided into 16 minor steps  
 Function: Permits rate adjustment independently of flange depth

**F. Shape**

Parameter Number and Usage: 5 MIDI  
 Range: 0 to 7  
 Internal Resolution: 8 steps  
 Function: Adjusts shape of flange curve for more time spent in the high frequency regions  
 Factory preset to 6



## 12. Specific Parameters for 6 Voice Chorus

<b>A. Feedback</b>	0	DECAY KNOB	MIDI
	Positive feedback around Delay 3 voice pair, 0 to 94%		
	Drives param #6 below to positive values only		
	Also available as MIDI parameter #0		
<b>B. Delay 1</b>	1	DELAY KNOB	MIDI
	Sets Delay 1, the base delay for all six voices (Pre-delay, in effect), rough values in ms		
	0, 8.2, 16.4, 24.6, 32.8, 49.2, 57.3, 73.7, 98.4, 123, 164, 213, 279, 367, 475, 623.		
	Also available as MIDI parameter #1, which can set finer values, still in 8.2 msec increments, between the larger step sizes.		
<b>C. Delay</b>			
Parameter Number and Usage:	4	Voice pair #2 Spread Delay	MIDI
	5	Voice pair #3 Spread Delay	MIDI
Range:	0 to 1 sec		
Internal Resolution:	8 millisecond increments		
Function:	The base delay for all 3 voice pairs is set by MIDI param #1 or the DELAY KNOB		
	These parameters add up to 1 second to voice pairs #2 and #3, independently		
	While the group delay has an exponential control curve that provides finer resolution at short delays, these delays are linear.		

## 13. Specific Parameters for Chromatic Resonator

<b>A. Master Resonance</b>	0	DECAY KNOB	MIDI
	Sets average resonance from 93% to 99%.		
	Drives parameter #6 (Master Resonance Feedback) to positive values only.		
<b>B. Fine Tuning</b>	1	DELAY KNOB	MIDI
	Fine tunes all twelve resonators -8 to +7 semitones from normal to match the tuning of your instrument.		
	The lowest resonator is normally set to 440 Hz.		
	Drives parameter #9 (Tuning).		
<b>C. Predelay</b>	3		MIDI
Range:	0 to 524 ms		
Internal Resolution:	2730 steps		
Function:	Spaces out the onset of resonance for 6 pairs of resonators to produce a strumming effect.		
	Factory preset to 130 ms		
<b>D. Low Frequency Cutoff</b>	4		MIDI
Range:	19.5 Hz to 13.5 kHz		
Internal Resolution:	256 steps		
Function:	High-pass filters the input audio to reduce boominess for low tunings.		
<b>E. Shimmer</b>	5		MIDI
Range:	Off to one resonator every 0.12 seconds.		
Internal Resolution:	16 steps		
Function:	Sets the period of resonator detuning.		
	Factory preset to change one resonator every 0.5 second.		

# MIDI Implementation Chart

Lexicon LXP-1

Multi-Effects Processing Module

Version: 1.0

Function	Transmitted	Recognized	Remarks
Basic Channel Default Channel	1 1-16	1 1-16	Memorized
Mode Default Messages Altered		Mode 3	
Note Number True Voice	X	0 - 127	Used as controller
Velocity Note ON Note OFF	X X	O X	
After Touch Key's Channel's	X X	X O	
Pitch Bender	X	O	
Control Change	X	0 - 127	
Program Change True #	X	0 - 127 0 - 127	
System Exclusive	O	O	
System Common :Song Pos :Song Sel :Tune	X X X	X X X	
System Real Time :Clock :Commands	X X	O X	Used as controller
Aux Messages :Local ON/OFF :All Notes OFF :Active Sense :Reset	X X X X	X X X O	

Mode 1: OMNI ON, POLY  
Mode 3: OMNI OFF, POLY

Mode 2: OMNI ON, MONO  
Mode 3: OMNI OFF, MONO

O : Yes  
X : No

Lexicon, Inc.  
100 Beaver Street  
Waltham MA 02154-8425  
(617) 891-6790  
Telex 923468  
Fax (617) 891-0340

Lexicon Part No. 070-06023

Printed in U.S.A.