IMPORTANT SAFETY INSTRUCTIONS – READ FIRST



This symbol, whenever it appears, alerts you to the presence of uninsulated dangerous voltage inside the enclosure-voltage that may be sufficient to constitute a risk of shock.



This symbol, whenever it appears, alerts you to important operating and maintenance instructions in the accompanying literature. Read manual.

Read instructions:

Retain these safety and operating instructions for future reference. Heed all warnings printed here and on the equipment. Follow the operating instructions printed in this user guide.

Do not open:

There are no user serviceable parts inside. Refer any service work to qualified technical personnel only.

Power sources:

Connect the unit to mains power only of the type described in this user guide or marked on the rear panel. The power source must provide a good ground connection.

Power cord:

Use the power cord with sealed mains plug appropriate for your local main supply as provided with the equipment. If the provided plug does not fit into your outlet consult your service agent. Route the power cord so that it is not likely to be walked on, stretched or pinched by items placed upon or against.

Grounding:

Do not defeat the grounding and polarization means of the power cord plug. Do not remove or tamper with the ground connection on the power cord.

Ventilation:

Do not obstruct the ventilation slots or position the unit where the air required for ventilation is impeded. If the unit is to be operated in a rack, case or other furniture ensure that it is constructed to allow adequate ventilation.

Moisture:

To reduce the risk of fire or electrical shock do not expose the unit to rain, moisture or use in damp or wet conditions. Do not place container of liquid on it, which may spill into any openings.

Heat:

Do not locate the unit in a place close to excessive heat or direct sunlight, as this could be a fire hazard. Locate the unit away from any equipment, which produces heat such as: power supplies, power amplifiers and heaters.

Environment:

Protect from excessive dirt, dust, heat, and vibration when operating and storing. Avoid tobacco ash, drink spillage and smoke, especially that associated with smoke machines.

Handling:

To prevent damage to the controls and cosmetics avoid rough handling and excessive vibration. Protect the controls from damage during transit. Use adequate padding if you need to ship the unit. To avoid injury to yourself or damage to the equipment take care when lifting, moving or carrying the unit.

Servicing:

Switch off the equipment and unplug the power cord immediately if it is exposed to moisture, spilled liquid, objects fallen into opening, the power cord or plug becomes damaged during a lightning storm or if smoke odor or noise is noted. Refer servicing to qualified technical personnel only.

Installation:

Install the unit in accordance with the instruction printed in this user guide.

TABLE OF CONTENTS

- Introduction 3**
 - Introduction 3
 - Features 3

- Front Panel Controls 4**
 - Input Gain Control 4
 - Input Impedance Control 4-5
 - Analog Output Control..... 5
 - HPF Control 5
 - Gain Switch 5
 - Phantom Switch 5
 - Phase Switch 6
 - Plate Voltage Switch 5-6
 - Meter Switch..... 6

- Digital Section Controls 6**
 - Digital Level Control 6
 - Dither Switch 6
 - Sample Rate Control 7
 - Optical Switch..... 8

- Front Panel Connections 8**
 - Instrument Inputs..... 8

- Rear Panel Connections 8**
 - Balanced Inputs..... 8
 - Balanced Outputs 8
 - Insert Jacks 9
 - Word Clock Jacks..... 9
 - ADAT Input..... 9
 - Optical Output..... 9
 - S/PDIF Output 9
 - AES/EBU Output 9

- Signal Path Flow 10**
 - Signal Path Flow Diagram 10

- Operating Instructions 10**
 - Obtaining the best noise performance..... 10
 - Adjusting the input impedance..... 10-11
 - Obtaining the perfect digital level setting..... 11
 - Setting the tube plate voltage 11

- Warranty Information 12**
- Service 13**
- Specifications 14**

DIGITAL MPA INTRODUCTION

The ART Digital MPA™ microphone preamplifier features a new low noise, high performance preamplification circuitry, designed for superior audio fidelity. Building upon the quality and success of great sounding products like the Pro MPA, ART engineers set out to develop the next generation of professional microphone preamplifier. The Digital MPA is the culmination of years of research and development, and sets a new standard for quality and value. Professional features and spectacular tone are what make the Digital MPA a world-class microphone preamplifier.

DIGITAL MPA FEATURES:

- Variable input impedance for flexible microphone voicing (150 Ohms to 2400 Ohms).
- Selectable plate voltage
- Large VU meters
- Front accessible meter trim
- Selectable between output level and tube warmth
- Improved discrete class A input microphone preamplifier
- Lower noise at low gains
- Lower THD
- Wider frequency response
- Front accessible Instrument Input Jack
- Very high input impedance
- Automatically switches to the instrument input when you plug in

The Digital MPA also features digital connectivity for use with various digital processors and digital recording devices. The Digital interface supports the following features and functions:

- 24-204KHz External sample rate
- 44.1K, 48K, 88.2K, 96K, 176.4K, 192K Internal sample rates
- 24/16 bit switchable dithering
- Wide dynamic range A/D
- Rotary Encoder for quick selection of sample rate and output format
- Separate analog and digital output level controls
- Digital Level LED meters
- ADAT optical I/O
- Sync to incoming ADAT data rate
- Switch selectable optical output (S/PDIF or ADAT)
- Selectable Pro/consumer output format
- AES/EBU output on cannon connector
- Two wordclock jacks allowing loop through



ART Digital MPA – Rear view image (above)

FRONT PANEL CONTROLS

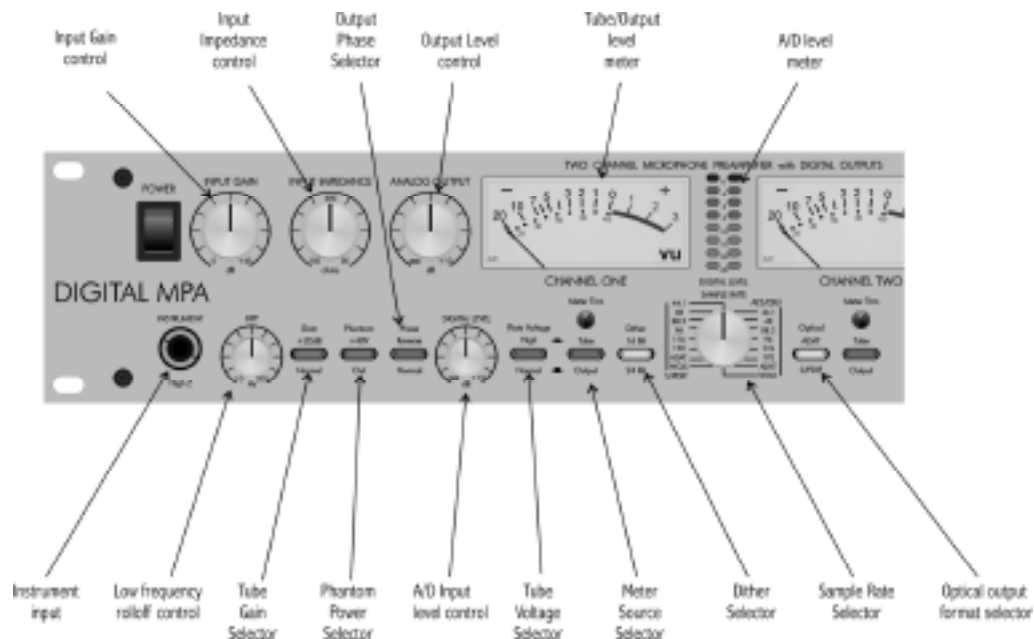

Input Gain Control

This control optimizes the input signal level before the tube gain is applied. Both Microphone and Instrument input gains remain the same and are affected by this adjustment. Input gain can be adjusted from 0dB (for line level signals) to 45dB of gain.

Use the analog meters in the TUBE setting to gauge how much input gain is required.

Additional gain is available via the Gain Switch (+20dB) and the Analog Output Control (+10dB) for a maximum of 75dB total.

The combination of these controls allows the user to adjust the signal level through the tube section, providing more or less “tube” sound as needed. To obtain more “tube” sound, increase input gain, use the +20dB Gain switch, “normal” plate voltage, and less analog output gain.

Both the microphone and instrument inputs are optimized for their respective sources as far as signal levels and noise performance. Running most of the gain on the input generally provides the best performance of the DMPA. Refer to the section titled “Obtaining the best noise performance with the DMPA” for more detailed instructions on setting the Input Gain control for the best results.

Input Impedance Control

This knob controls the Mic/line input amplifier impedance. This function allows variable voicing of any microphone.

Refer to the application section titled “Adjusting the Input Impedance” for more information on making the most of this function.

The 1/4" instrument input is NOT affected by this control, and remains high (>1M Ohm) impedance.

Analog Output control

The output signal level at the rear output jacks is adjusted by this control. It can provide from +10dB of gain (fully clockwise) to completely muted. You can see the effects of this adjustment reflected in the analog meters when the meter switch is set to "output".

HPF control

The HPF is a single tuned High Pass Filter that is frequency tunable. The input signal can be filtered to remove "pops" or other extraneous low frequency information. This control moves the rolloff frequency from 10 Hz (fully CCW) to 200 Hz (fully CW). Since it is single tuned (*the same as single pole, the simplest kind of filter*), it preserves some low frequency content so its use is less obtrusive. It is especially useful in close mic'd applications.

Gain switch

The Gain switch is used in conjunction with the input gain control to adjust signal levels through the DMPA. When depressed, the tube circuit provides 20dB more gain in the signal path. This also has the effect of driving the tube harder and making the tube the dominant source of gain and overload character.

Phantom switch

Phantom power on the microphone input is turned on and off with this switch. Depressing the switch will power condenser microphones and other 48volt phantom powered devices. Phantom power is supplied to pins 2 and 3 of the input jack.

NOTE:

1) *Dynamic microphones are NOT affected by Phantom power, although it should be turned off when using dynamic microphones or line level inputs.*

2) *Although the 48volt phantom power ramps up and down slowly it may still create a pop. Mute the output of the DMPA when engaging or disengaging phantom power to prevent damage to equipment following the DMPA.*

Phase switch

The Phase switch can invert the phase of the audio signal path in either channel. The Phase switch is located after the tube circuit in the signal path, so you can hear slight differences between different phase selections in the "normal" plate voltage mode near saturation. There are a number of reasons why adjusting the phase is needed. These include, wiring errors and inversions in some audio equipment. Some microphones sound different depending on the phase chosen.

If two microphones are out of phase, they may cancel at various frequencies (depending on the distance between them). If this happens, try changing the phase of one of the microphones and see if there is an improvement.

Plate Voltage switch

This switch sets both the tube bias point and the plate voltage level that the balanced differential tube circuit runs at. The amount of headroom is adjusted by using the Gain switch and the input

Gain control. The DMPA takes about 10-30 seconds to smoothly transition from one mode to the other. There is a slight increase in gain in the “High” plate voltage mode.

In the “normal” (OUT) position, the tube distortion gradually rises until it smoothly clips. The tube is run almost completely open-loop in this mode, providing a musical tube “crunch” when overdriven with a natural recovery from clipping. The tube section can be more easily overdriven when the gain switch is in. This mode brings out the harmonics in the input sources, particularly stringed instruments.

The tube circuit runs extremely clean in the “high” (IN) position of the plate voltage switch. As signal levels rise distortion remains very low until within 6dB of clipping, where the overload characteristics smoothly limit the signal swing. There is increased bandwidth (>100KHz), and headroom in this mode as well.

Meter Switch

The analog meters can monitor either the output signal at the output jacks (“output” position) or the tube output level (“tube” position).

VU on the meter measures +4dBu at the output jacks in “output” mode.

When in “tube” mode there is 10 to 15dB of headroom above 0VU before the tube saturates (for “normal” and “high” plate voltage settings respectively).

Digital Section Front Panel Controls

Digital Level Control

The levels driving the A/D converter are adjusted with this control. The topology of the DMPA lends itself to simultaneous use of the analog and digital outputs, as each has its’ own level control. Common to both is the output signal of the tube circuit.

The Digital level control is variable from +10dB to $-\infty$ (fully muted).

An insert jack is located before the digital level control, allowing processing to be added before digital conversion.

As the Digital Level Control is used refer to the Digital level LED meter which indicates both peak and average level present at the A/D converter input. This meter helps you get the perfect level adjustment and avoid clipping the A/D. Refer to the section titled “Obtaining the perfect digital level setting” for more detail on the operation and use of these features.

Dither Switch

The DMPA possesses a 24-bit A/D converter. When the output of the unit goes off to a system that can handle only 16 bit data, the 8 least significant bits of data are ignored (truncated). This leaves the sound with gritty “digital” sounding signals at very low levels. Depressing the Dither switch adds a dither component that when truncated replaces this with a more musical sound as the levels trail off into the noise floor.

Generally, keep the unit in 24-bit mode (the out position of the switch) unless you are connected to a system that will truncate the signal to 16 bits. The 24-bit mode has significantly greater dynamic range.

Sample Rate Control

The Sample rate knob determines both the output sample rate of the DMPA as well as the digital data format. You can select either AES/EBU (pro) format or S/PDIF (consumer) data format. This allows the DMPA to interface to a wide variety of digital inputs.

The S/PDIF mode has copy protection turned off, and identifies itself as an A/D converter with 24 bit data.

The AES/EBU mode identifies itself as either locked (when set to an internal sample rate) or unlocked (when set to Wordclock or ADAT as a sync source). No other channel status data is sent.

The first step in determining the correct sample rate setting is to choose the data format. If you plan on using the cannon output (AES/EBU jack) make a sample rate selection on the right half of the selection range.

If using the coaxial (RCA jack) output make a selection of the left side of the sample rate knob.

The internal sample rate can be set from 44.1KHz to 192KHz. Simply select the correct rate by turning the knob to the rate you need and the DMPA will use its' internal crystal controlled oscillator to accurately generate the selected timing.

Be careful in adjusting this control. Some equipment is not capable of the available sample rates and may produce damaging side effects. Always turn down levels following the DMPA when changing the sample rate.

External sync sources are Wordclock and ADAT INPUT.

Wordclock is a 5V logic level signal interfaced by a BNC connector on the rear of the unit. The range of wordclock accepted by the DMPA is 28KHZ to 212 kHz. It is recommended that you use wordclock whenever possible, as this will minimize interface errors with other equipment.

NOTE: When using the ADAT optical output, the maximum sample rate is limited to about 50KHz. If wordclock exceeds this the ADAT output (if selected) will fail.

The ADAT Input on the rear panel is used as a timing reference as well as a source of data to be passed on to the ADAT output of the DMPA.

If the unit CANNOT sync to an external source (either out of range, not connected or a system failure), the optical Output select switch will blink. (You may see this switch flash once between changing sample rates, indicating the fraction of a second it takes to settle to the new rate. This is normal). *NOTE: When using the ADAT Input as a sync source, the maximum sample rate is limited to about 50KHz Sample Rate (selection being set to ADAT - not wordclock or any other fixed sample rate).*

Optical Switch

The optical output jack of the DMPA can have one of two formats. When this switch is depressed AND lit blue, this jack will output 8 channels of ADAT. (*ADAT cannot be output if the sample rate exceeds 48KHZ - the Sample Rate selection being set to an internal rate*). In this case the switch cap will NOT be illuminated, and the output format will revert to 2-channel mode (TOSLINK).

When ADAT output is active, The left channel of the DMPA is output on CH1, the right channel of the DMPA is CH2, and the rest of the channels consist of data received from the ADAT Input jack. When the switch is in the OUT position OR the switch cap is not lit, the output consists of two channels of digital audio in the format selected by the Sample Rate Switch.

The Lighting of the optical switch cap serves a second function. If it is blinking, there is a timing problem in the digital section. This usually happens when there is not a valid external timing input selected.

Front Panel Connections

Instrument Inputs

The 1/4" jacks on the front panel serve as an instrument input. The input impedance is always >1M Ohm and the gain can be adjusted by the Input Gain Control. The maximum input signal level is +17dBu (5Vrms) @ minimum input gain.

When you plug into this jack it DISABLES the balanced input on the rear of the unit. This feature allows you to keep the rear input patched in, and use the instrument input to switch to a different source. The instrument input allows the DMPA to serve as a great DI device as well.

Rear Panel Connections

Balanced Inputs

The DMPA's XLR connectors follow the AES standard of Pin 1 = Ground, Pin 2 = Hot (+), Pin 3 = Cold (-). The Balanced inputs have an input impedance that is variable from 150 to 3K Ohms via the front panel control. The Maximum input level is +19dBu balanced and +17dBu unbalanced.

Balanced Outputs

The DMPA 's flexible active balanced outputs are available on both 1/4" and cannon connectors. They offer low impedance for driving long cable runs and are intelligent so they maintain the same output level whether it is balanced or unbalanced.

The DMPA's XLR connectors follow the AES standard of Pin 1= Ground, Pin 2= Hot (+), Pin 3= Cold (-). The balanced 1/4" phone jacks are typical Tip = Hot (+), Ring = Cold (-), Sleeve = Ground

Maximum output level is +26 balanced and +20 unbalanced.

Insert Jacks

The insert jacks are used to process the audio passed on to the A/D converter. The Insert Jacks are wired: Tip = Input, Ring = Output, Sleeve = Ground. The input impedance is 10K Ohm and the output impedance is 1K Ohm. The minimum input signal required to drive the A/D to clip is +12dBu (3V rms)

Wordclock Jacks

The DMPA offers Wordclock input on a BNC connectors. A 5V logic level signal is required to drive the digital clock circuitry. Both BNC connectors are tied together allowing you to loop wordclock through the DMPA saving cabling complexity.

ADAT Input

The ADAT input for the DMPA is a standard optical connector. This input is used when syncing to ADAT for timing purposes. It is also used as a data source for channels 3-8, as the channels NOT transmitted by the DMPA are passed from this input to the optical output (when the optical output is set to ADAT mode).

Optical Output

The Optical Output Switch selects the data source for this jack. This feature allows the DMPA to output to multiple units in different formats at the same time.

In S/PDIF mode, two-channel audio is present. The data is identical to the coaxial and cannon digital output connectors.

In ADAT mode the DMPA transmits its' A/D data on the first two channels and passes information from the ADAT input jack (CH3-8) on to the other channels.

Using the optical output in S/PDIF is recommended over the coax output, as it is the most robust and reliable of all the digital outputs. When connecting to consumer gear, use a sample rate selection in the S/PDIF range of the selector knob.

S/PDIF Output

The S/PDIF coax connector allows the DMPA to connect to a wide range of consumer and professional equipment. This output is .5V p-p (*peak-to-peak*) (when connected) isolated from ground, and has a 75 Ohm impedance. The same data is sent to both this connector and the AES/EBU output, but it is recommended that you not use both at the same time, as the AES/EBU output may work, but there will be too great a loss in level to meet the S/PDIF standard. Choose a sample rate in the S/PDIF range of the front panel selector when using this jack.

AES/EBU Output

The AES/EBU output of the DMPA is a 5V p-p signal with a 110 Ohm impedance. This cannon connector is driven by the same drive circuitry and isolation transformer and as the S/PDIF output.

Choose a sample rate in the AES/EBU range of the front panel selector when using this jack. If this is not done equipment that follows the DMPA may not recognize the data as valid.

SIGNAL PATH FLOW DIAGRAM

The signal path of the DMPA consists of a discrete class A microphone pre-amp followed by a Hi Pass Filter, a balanced differential tube circuit with a 20dB Gain switch and then the phase switch. At this point the signal passes to both the analog output and the Insert jacks. The insert jacks allow processing of the signal before its' level is adjusted by the Digital Level control and passed to the A/D. You can use the A/D converters of the DMPA independent of the analog functions by simply inserting a signal into this insert point.

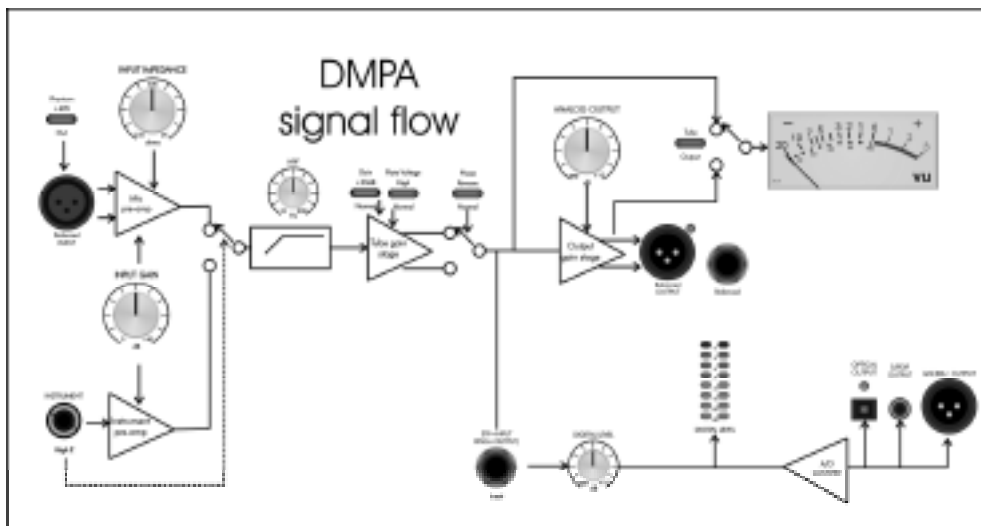

DMPA OPERATING INSTRUCTIONS

Obtaining the best noise performance with the DMPA

Start by turning down the Input Gain knob and centering the Analog Output knob. Use the analog meter to view the operating level by depressing the switch under the center of the analog meter. The meter will now indicate how much tube headroom there is. Set the +20dB switch to the out position.

Rotate the Input Level Knob until the meter reads above -10dB . If you have turned the input knob fully clockwise and the indicated level is still below -10dB on the meter, center the input knob and depress the Gain switch. Increase the input gain until there is sufficient level.

This procedure optimizes the gain elements to provide the widest dynamic range possible.

Adjusting the Input Impedance

The same microphone can sound different on various pre-amps. One reason is that every pre-amp presents a different load to its' input, some even change as gain is changed! Our third generation discrete front end was designed to be absolutely transparent. Every nuance of the microphone is maintained providing detail masked by inferior pre-amps. The Input Impedance Control is one key element in providing new versatility in voicing microphones.

NOTE: the Input impedance control only affects the cannon connector inputs. The 1/4" instrument input on the front panel is NOT affected by this control in any way. The instrument input impedance is ALWAYS $\geq 1M$ Ohm.

Dynamic microphones are affected as much as phantom powered units.

We provide a continuously variable impedance control to allow you to fine-tune the voicing, finding the perfect interaction between microphone and pre-amp.

Start by setting the centering the Input Impedance knob. This provides a 600-Ohm load.

Lower impedance loads will reject more noise picked up by cabling, and dampen microphone resonance. Lower impedances tend to focus the sound more. Higher impedance settings provide a more "open" sound.

Obtaining the perfect digital level setting

The Digital Level Meter indicates both peak and average levels present at the A/D converter. The 0dB LED indicates that there is less than 1dB of headroom before clipping. The highest peak level reached is held for 1 second by a single LED and the average level is indicated by the remaining LEDs, lit in series.

It is recommended you start with the Digital Level Control centered. Adjust the input gain and +20dB switch such that the digital meter holds peaks at -3dB and occasionally hits the red 0dB LED. This setting will provide the best dynamic range AND the tube will saturate before the A/D clips (on heavy overloads).

If you want more tube headroom, set the digital level control fully clockwise.

If you need to compress the input signal before it is converted to a digital signal, use the rear panel Insert Jacks. The insert point is located between the tube output and the Digital Level control. This allows insertion of a dynamics processor with the ability to tweak the A/D input sensitivity from the DMPA front panel.

Setting the Tube Plate Voltage

The DMPA allows the user select between one of two vastly different tube bias and power supply levels. The transition between either setting is smooth and quiet and the gain variation is minimal.

NOTE: It takes 15-30 seconds for the tube circuit to fully transition between either mode. During this time, the unit passes a signal and the only noticeable change is a slight increase in level in the "HIGH" setting.

The "Warm" setting produces a smooth transition from very clean low levels up to a "round" saturated clipping on peaks. This setting is reminiscent of old tube gear, and used to get the most tube-like sound out of the unit. Common uses include tracking with instruments.

The "High" setting of the plate voltage switch has increased bandwidth and headroom, very low distortion and runs extremely clean until it reaches a point of saturated clipping. The clipping is well controlled and still sounds natural. This setting is incredible on vocals.

WARRANTY INFORMATION

Limited Warranty

Applied Research and Technology will provide warranty and service for this unit in accordance with the following warrants:

Applied Research and Technology (A R T) warrants to the original purchaser that this product and the components thereof will be free from defects in workmanship and materials for a period of five years from the date of purchase. Applied Research and Technology will, without charge, repair or replace, at its option, defective product or component parts upon prepaid delivery to the factory service department or authorized service center, accompanied by proof of purchase date in the form of a valid sales receipt.

Exclusions

This warranty does not apply in the event of misuse or abuse of the product or as a result of unauthorized alterations or repairs. This warranty is void if the serial number is altered, defaced, or removed.

A R T reserves the right to make changes in design or make additions to or improvements upon this product without any obligation to install the same on products previously manufactured.

A R T shall not be liable for any consequential damages, including without limitation damages resulting from loss of use. Some states do not allow limitations of incidental or consequential damages, so the above limitation or exclusion may not apply to you. This warranty gives you specific rights and you may have other rights, which vary from state to state.

For units purchased outside the United States, an authorized distributor of Applied Research and Technology will provide service.

SERVICE

The following information is provided in the unlikely event that your unit requires service.

- 1) Be sure that the unit is the cause of the problem. Check to make sure the unit has power supplied, all cables are connected correctly, and the cables themselves are in working condition.
- 2) If you find the unit to be at fault, write down a complete description of the problem, including how and when the problem occurs. Please write down a description of your complete setup before calling Customer Service.
- 3) Call the factory (585-436-2720) for a Return Authorization (RA) number.
- 4) Pack the unit in its original carton or a reasonable substitute. The packing box is not recommended as a shipping carton. Put the packaged unit in another box for shipping. Print the RA number clearly on the outside of the shipping box. Print your return shipping address on the outside of the box.
- 5) Include with your unit: a return shipping address (we cannot ship to a P.O. Box), a copy of your purchase receipt, a daytime phone number, and a description of the problem.
- 6) Ship only your unit and its power supply (keep your manual!) to:

APPLIED RESEARCH AND TECHNOLOGY

215 TREMONT STREET

ROCHESTER, NEW YORK 14608

ATTN: REPAIR DEPARTMENT, RA# _____

- 7) Contact our Customer Service department at (585) 436-2720 for your Return Authorization number or questions regarding technical assistance or repairs. Customer Service hours are 9:00 AM to 5:00 PM Eastern Time, Monday through Friday.

DMPA SPECIFICATIONS

Dimensions.....	6.5" D x 19.0" W x 3.5" H
Weight	12 Lb.
Frequency Response.....	15Hz to 48 kHz (+0, -1dB) @ normal plate voltage 15Hz to 120 kHz (+0, -1dB) @ high plate voltage
Dynamic range	>110dB ("A" weighted)
CMRR.....	>90dB
THD	<0.005% (typical)
Equivalent Input Noise.....	-133dBu (XLR, "A" weighted)
Maximum Input Level.....	+20dBu (cannon)
Maximum Instrument Input	+17dBu
Input Impedance.....	150-3000 Ohms adjustable (XLR) >800K Ohms (Instrument)
Maximum Output Level.....	+27dBu (XLR)
Output Impedance	< 47 Ohms (XLR)
Maximum Gain	75dB
Meter Calibration	0 VU = +4dBu output
High Pass Filter	single pole, 10-200 Hz adjustable
Power Requirements	100-125 VAC, 25W. Export Units configured for country of destination

Digital Section:

A/D Frequency Response	
@44.1KHz sample rate	10Hz to 21.25KHz (+0, -1dB)
@88.2KHz sample rate	10Hz to 42.50KHz (+0, -1dB)
@196KHz sample rate	10Hz to 81KHz (+0, -1dB)
A/D Dynamic Range	>115dB "A" weighted (typ.)
A/D THD	<0.001% @1K (typ.)
A/D Input Sensitivity.....	+12dBu min
A/D Insert Input Impedance.....	>10K Ohms



The ART Digital MPA™ is ADAT licensed.